

**Gorbel® Work Station Cranes with
250#-4000# Extended End Trucks**

1. Prior to assembly make sure single wheel trolley moves freely in mounting bracket.
2. Bolt one (1) anti-kick up assembly to each end of the end truck, using the 3/8" hardware provided.
Note: endtruck tubes must have plates with tapped holes welded on ends.
3. Back the anti-kick up adjustment bolt off as far as possible without removing the bolt.
4. Install the endtruck assembly as instructed in Step 5 of the installation and maintenance manual.
5. Adjust the anti-kick up so that the wheel makes contact with the top inside of the runway. Back off adjusting bolt one (1) turn. Once all anti-kick ups are adjusted, move the bridge (unloaded) through its full travel and check for binding of the anti-kick up wheels. If binding occurs, back the adjustment bolt off 1/2 turn at a time until the binding no longer occurs. Tighten locknut.

Note: If proper adjustment of anti-kick up is not made, smooth operation of system will be affected.

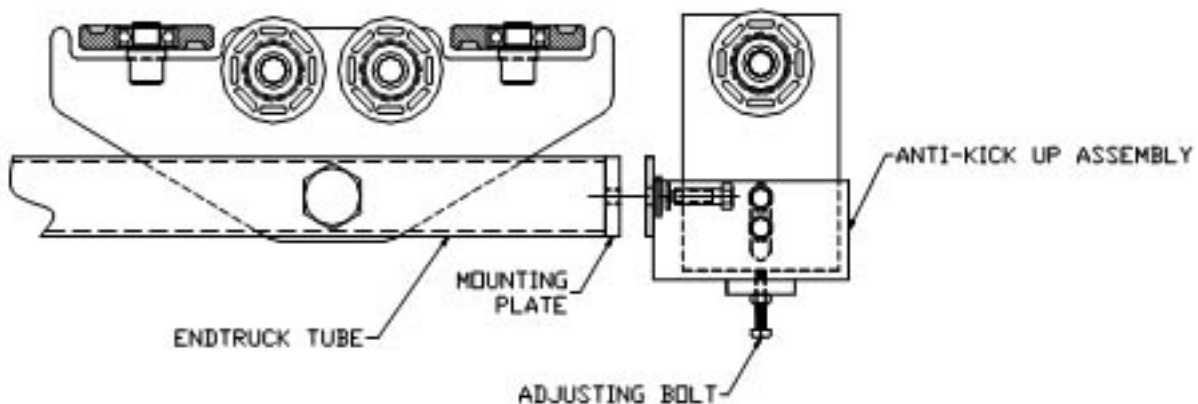

Figure 1.