

Gorbel® Wheel Plates

1. Prior to assembly make sure single wheel trolley moves freely in mounting bracket.
2. Bolt one (1) anti-kick up assembly to each end of the wheel plate, using the 1/4" hardware provided.
3. Back the anti-kick up adjustment bolt off as far possible without removing the bolt.
4. Install the wheel plate assembly on to the bridge.
5. Adjust the anti-kick up so that the wheel makes contact with the top inside of the runway. Back off adjusting bolt one (1) turn. Once all anti-kick ups are adjusted, move the wheel plate (unloaded) through its full travel and check for binding of the anti-kick up wheels. If binding occurs, back the adjustment bolt off 1/2 turn at a time until the binding no longer occurs. Tighten locknut.

Note: If proper adjustment of anti-kick up is not made, smooth operation of system will be affected.

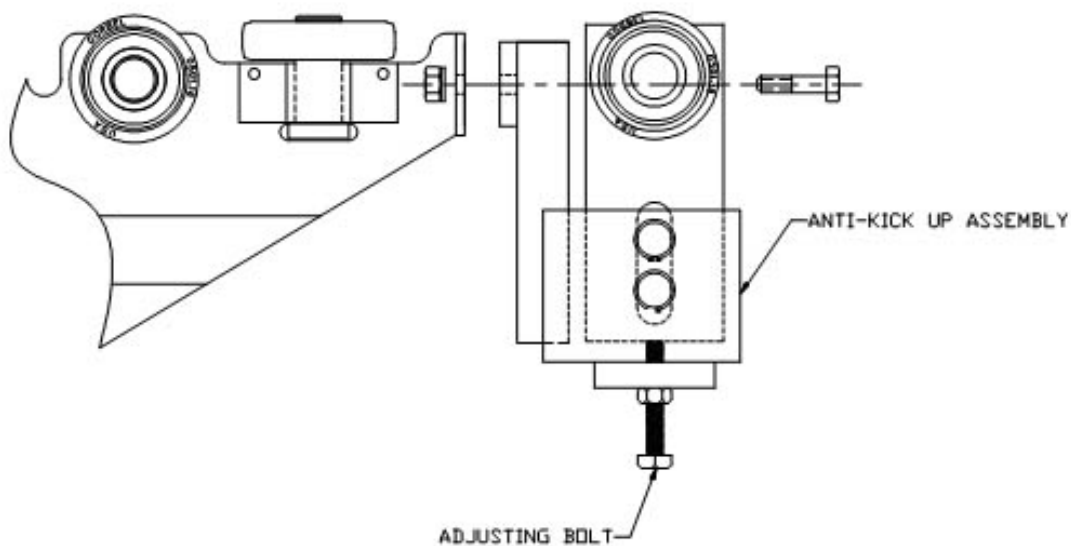

Figure 1.