

74100FTT, 74101FTT, 74102FTT, 74103FTT

Important note regarding festoon stack-up section and splice joints:

Festoon Stack-Up Note: To resist kick-up and side-loading forces, the Tool Trolley utilizes an additional pair of wheels that run along the top/inside surface of the crane/monorail tracks. Because of this, the trolley itself cannot pass into a festoon stack-up that utilizes a bolted connection (i.e. the trolley cannot pass under the through-bolt). Therefore, the festoon stack-up section must be field welded in order to allow the trolleys to pass into the stack-up section. Refer to the crane/monorail Installation & Maintenance Manual for welding instructions.

Splice Joint Note: To prevent the trolley from becoming obstructed when passing between adjoining tracks, the inside surfaces of the mating track components must be flush horizontally and vertically. The tool trolley has six (6) possible points of contact with the track, which necessitates that the splice joints are assembled properly. ***When trolleys carrying a load pass through a splice joint, any gap or offset between the tracks may affect the performance of the trolley.***

Installing electric cable/air hose with Festoon Tool Trolleys:

1. Loosen nuts and clamp-plate enough to thread electric cable/air hose between the U-bolt legs and clamp plate on the festoon trolley.
 - Tip -- Make sure the electric cable/air hose rests on top of the clamp plate, not on the U-bolt itself, as shown.
2. Secure cable by tightening nuts, forcing clamp plate snug against electric cable/air hose.
 - Tip -- Be careful not to tighten nut too tight; this can cause damage to electric cable/air hose, or restrict flow in air hose.

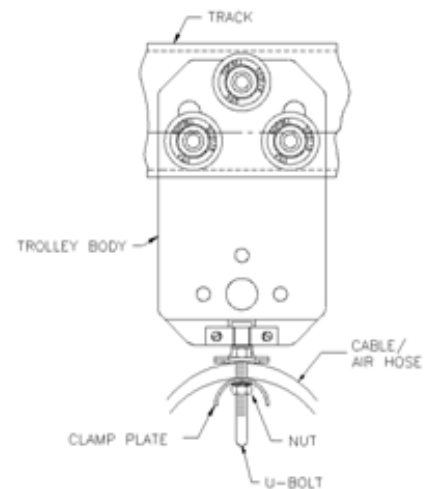

Installing Tools or Tool Balancers on the Festoon Tool Trolley:

Note: Tooling should be hung or bolted directly to the trolley body, not to the festoon saddle.

****In order to install tooling on the trolley, the festoon pivot saddle must be removed.***

1. Remove the festoon pivot assembly by unthreading the mounting hardware connecting the pivot's retaining plates to the trolley body.

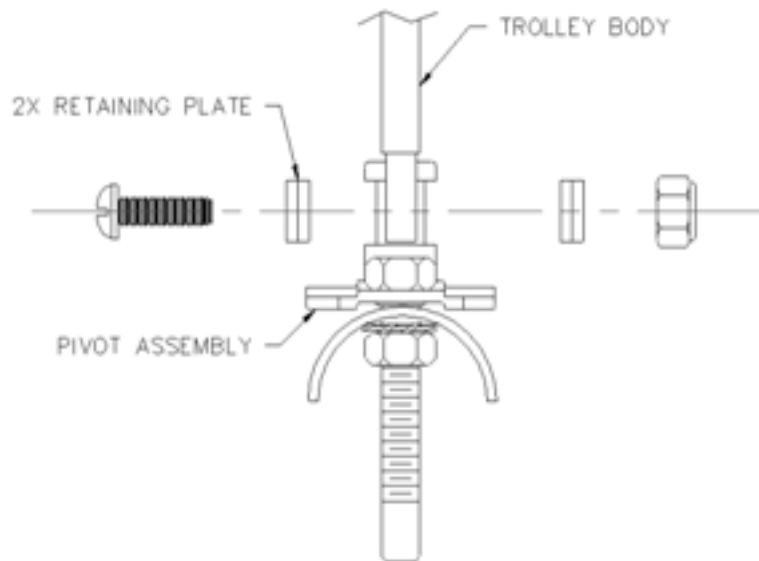

2. Tooling may now be hung or bolted to the trolley plate without interference.

