

Installation, Operation, & Maintenance Manual

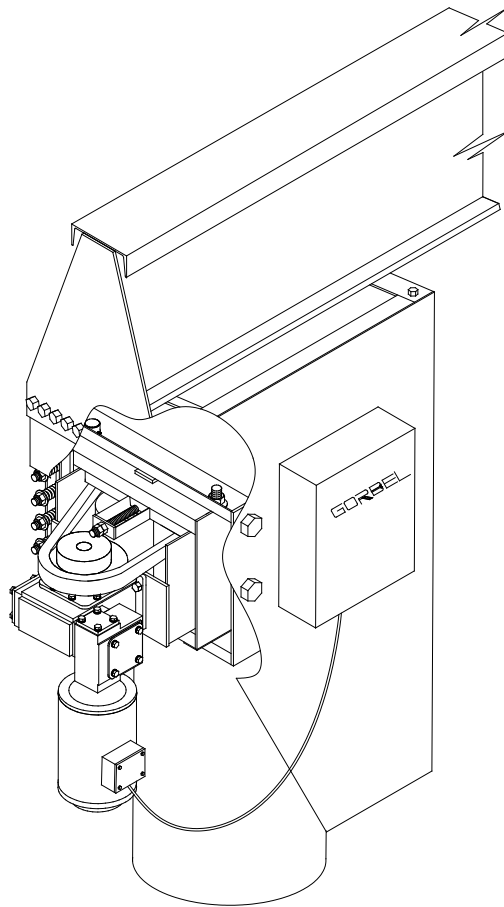

**IMPORTANT!
DO NOT DESTROY**

RETROFIT II TRACTION DRIVE

Gorbel® Customer Order No. / Serial No. _____

Gorbel® Dealer _____

Date _____
Month Year

TABLE OF CONTENTS

| | |
|---|-----|
| Introduction..... | 1 |
| Installation | |
| Step 1- Pre-Assembly..... | 2 |
| Step 2- Installation and Drive Assembly Instructions | 2-3 |
| Step 3A - Electrification Installation (Standard Drive)..... | 4 |
| Step 3B - Electrification Installation (Variable Frequency Control Drive) | 4-5 |
| Step 4- Limit Switch Installation | 6-8 |
| Step 5- Endstop/Tagline Installation..... | 9 |
| Step 6- Shut Down Procedures..... | 10 |
| Step 7- Final Steps..... | 10 |
| Safety Warnings and Precautions..... | 10 |
| Troubleshooting Guide | 11 |
| Trunnion Roller Replacement..... | 11 |
| Crane Operator Instructions | 12 |
| General Operating Suggestions..... | 12 |
| Limited Warranty | 13 |
| Maintenance Schedule..... | 14 |
| Lubrication Schedule..... | 14 |

Questions? Concerns? Comments? Please call (800) 821-0086 (US and Canada) or (585) 924-6262 (Outside US)

INTRODUCTION

Thank you for choosing a Gorbel® Retrofit II to solve your material handling needs. The innovative design and heavy-duty construction of a Retrofit II added to an existing jib will provide a superior quality product that will offer years of long term value. All Gorbel® cranes are pre-engineered for powered hoist operation. The hoist weight allowance is 15% of the crane capacity (for example, a crane rated for 1000 pounds allows for a 1000-pound live load plus 150 pounds for the weight of the hoist). There is also an allowance of 25% of the crane capacity for impact caused by hoist use. Gorbel® Free Standing Jib Cranes will provide many years of dependable service by following the installation and maintenance procedures described herein.

Dimensions contained in this installation manual are for reference only and may differ for your particular application.

Normal safety precautions: These include, but are not limited to:

- Checking for obstructions in crane rotation
- Checking that all bolts are tight and have lockwashers
- Making sure that endstop is in place
- Making sure that festooning cannot be snagged or pinched

For additional safety precautions see page 12.

WARNING

Only competent erection personnel familiar with standard fabrication practices should be employed to assemble these cranes because of the necessity of properly interpreting these instructions. Gorbel is not responsible for the quality of workmanship employed in the installation of a crane according to these instructions. Contact Gorbel, Inc., at 600 Fishers Run, P.O. Box 593, Fishers, New York, 14453-0593, 1-800-821-0086, for additional information if necessary.

WARNING

Equipment described herein is not designed for, and should not be used for, lifting, supporting or transporting humans. Failure to comply with any one of the limitations noted herein can result in serious bodily injury and/or property damage. Check State and Local regulations for any additional requirements.

WARNING

Consult a qualified structural engineer to determine if your support structure is adequate to support the loads generated by anchor bolt force, overturning moment, or axial load of your crane.

WARNING

Crane cannot be utilized as a ground: A separate ground wire is required. For example, systems with 3-phase power require 3 conductors plus one ground wire.

WARNING

Reference American Institute of Steel Construction (AISC) manual of Steel Construction (9th edition), Part 5, Specification for Structural Joints using ASTM A325 or A490 bolts (section 8.d.2) for proper procedures to follow when using any torque tightening method.

WARNING

Do not field modify crane in any way. Any modifications without the written consent of Gorbel, Inc. will void warranty.

INSTALLATION

STEP 1 - PRE-ASSEMBLY

➡ **TIP:** Packing list can be found in plastic pocket in hardware box.

- 1.1 Read entire manual **before** installing the Retrofit II.
- 1.2 Check packing list to ensure no parts have been lost prior to initiating assembly of the Retrofit II.
- 1.3 Tools and materials (by others) typically needed to assemble Retrofit II:
 - Ladders/man lifts
 - Hand tools
 - Torque wrench

STEP 2 - INSTALLATION AND DRIVE ASSEMBLY INSTRUCTIONS

- 2.1 Take main frame assembly and place it between the side plates of the head assembly (*diagram 2A*, page 3).
- 2.2 Measure 1" down from the bottom edge of the top plate of the mast to the top of main frame assembly. Measure 2-1/4" from mast face to inside edge of main frame assembly.
- 2.3 Mark hole positions from main frame assembly onto head assembly side plates. Holes should be in line and run parallel to mast face.
- 2.4 Drill three (3) Ø1-1/16" holes in each side plate.
- 2.5 Mount main frame assembly between side plates using Ø1" bolts, lockwashers and hex nuts provided.
- 2.6 Insert drive mounting frame into spring tension frame using Ø1" pivot rod and cotter pin to secure the assembly.
- 2.7 Insert spring pressure rod assembly into main frame assembly. Secure with cotter pin.
- 2.8 Attach drive mounting frame and spring tension frame (assembled in Step 2.6) to the main frame using the Ø1" pivot rod and hardware.

➡ **TIP:** The reducer and motor are already mounted to the drive mounting frame as shown in *diagram 2B*, page 3.

- 2.9 Tighten the hardware to compress springs after "0" clearance is taken up. Compress spring 1/2" to 1". If slippage occurs, additional compression may be needed. Do not allow coils of spring to bind.

➡ **TIP:** Be sure safety nuts are in place on all springs before tightening.

➡ **TIP:** Be sure all power is off before wiring.

- 2.10 Mount electrical enclosure (if applicable) to side plate and connect power, motor and control connections according to the electrical print included. A minimum of two (2) button pendant (by others) with on/off to operate mainline contactor is required to rotate jib in the clockwise and counterclockwise directions.
- 2.11 If electrical was not ordered with a fuse block or a fusible disconnect switch, some type of fused protection must be provided between power supply and electrical enclosure.

STEP 2 - INSTALLATION AND DRIVE ASSEMBLY (CONTINUED)

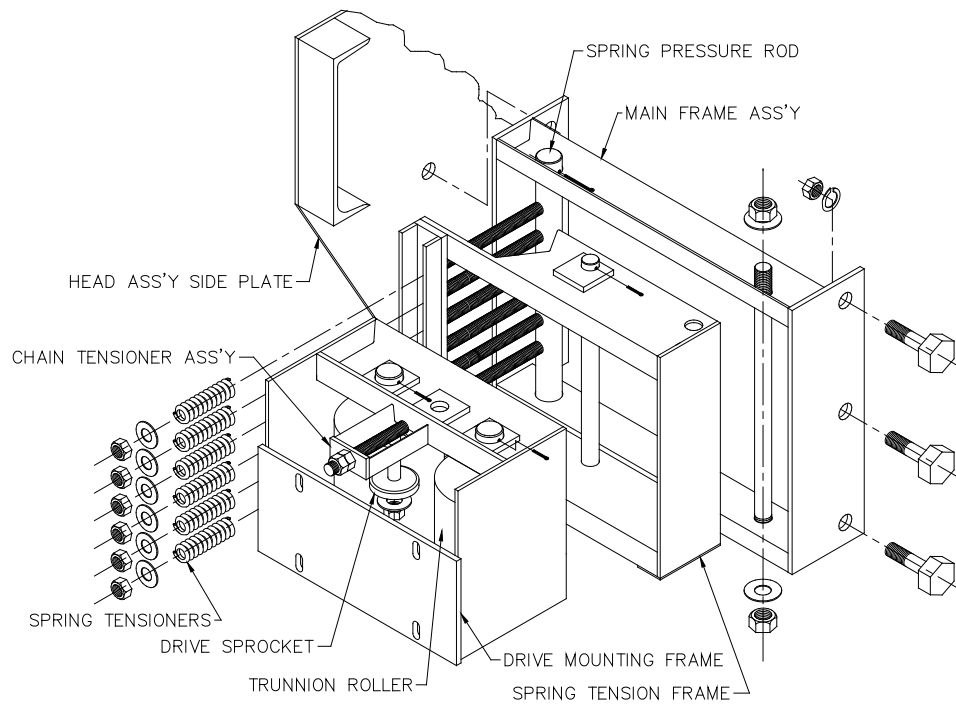

Diagram 2A. Frame Installation.

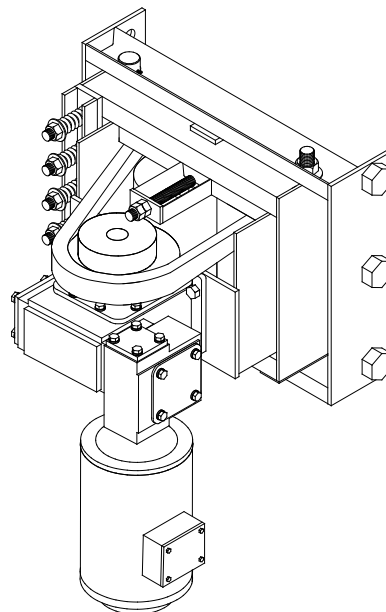

Diagram 2B. Retrofit II.

STEP 3A - ELECTRIFICATION INSTALLATION (STANDARD DRIVE)

JIB DRIVE CONTROLLER

Jib rotation control is by magnetic reversing starters. For troubleshooting and general information, a brief summary is included below. Other controllers may be available. See the appropriate enclosed insert for any optional equipment where applicable.

SINGLE SPEED OPERATION

Single speed operation utilizes the drive ratio of the reducer and the ratio of the drive to driven sprockets to produce the standard jib rotation speed. These ratios are determined by the crane parameters (span, capacity, indoor, outdoor, etc.).

Materials typically contained within the electrical enclosure are as follows:

- Mainline Fuseblock
- Branch Fusing (Hoist)
- Control Transformer
- Terminal Strip
- Reversing Starters
- Thermal Overloads
- Mainline Contactor

STEP 3B - ELECTRIFICATION INSTALLATION (VARIABLE FREQUENCY CONTROL DRIVE)

JIB DRIVE CONTROLLER

The drive controller for the jib drive is pre-programmed at Gorbel for single speed, two speed, or three speed operation. For troubleshooting and general information, a brief summary of how the drive controller is designed to be used is included below. No additional programming is required. All options utilize an adjustable speed controller.

WARNING

The drive controller drive must only see its own internal voltage and not be connected to an external voltage source. Allowing 24 or 120 control voltage to go through the drive will PERMANENTLY DAMAGE the internal controls!

SINGLE SPEED OPTION

This option utilizes the drive ratio of the reducer and the ratio of the drive to driven sprockets to produce the standard jib rotation speed. These ratios are determined by the crane parameters (span, capacity, indoor, outdoor, etc.). The drive controller is then programmed for the motor to operate at normal speed (60 Hz).

TWO SPEED OPTION

This option varies the motor speed to determine the desired jib drive speeds. The motor controller is then programmed for the motor to operate at two different percentages of full speed based on the desired speeds specified by the customer at the time the order is placed.

STEP 3B - ELECTRIFICATION INSTALLATION (VARIABLE FREQUENCY CONTROL DRIVE) (CONTINUED)

THREE SPEED OPTION

This option is similar to the two speed option listed above. The motor controller is programmed for the motor to operate at three different percentages of full speed based on the desired speeds specified by the customer at the time the order is placed.

➡ **NOTE:** The two or three speed options listed above consist of two or three pre-set speeds, they are not infinitely variable during use.

DRIVE CONTROLLER PROGRAMMING

Gorbel pre-programs a number of parameters in the drive controller prior to shipment. The remaining parameters are left at the factory default settings. All parameters are stored on the EPM module. These parameters are as follows:

| Parameter # | Name - SCL/SLM Drive | Name - SCF Drive | New Value - (Setting) |
|-------------|------------------------|------------------------|---------------------------------|
| 1 | Line Voltage | Line Voltage | High or Low (see manual) - (01) |
| 4 | Stop Method | Stop Method | Ramp to stop - (03) |
| 5 | Standard Speed Source | Standard Speed Source | Preset speed - (02) |
| 10 | TB-13A Function Select | TB-13A Function Select | Run reverse - (06) |
| 11 | TB-13B Function Select | TB-13B Function Select | Preset speed - (04) |
| 12 | TB-13E Function Select | TB-13C Function Select | Preset speed - (04) |
| 17 | Rotation | Rotation | Forward and Reverse - (02) |
| 19 | Acceleration | Acceleration | 4 seconds |
| 20 | Deceleration | Deceleration | 4 seconds |
| 23 | Minimum Frequency | Minimum Frequency | 0 Hz |
| 24 | Maximum Frequency | Maximum Frequency | 60 Hz |
| 26 | Motor Overload | Motor Overload | As required (see manual) |
| 31 | Preset Speed 1 | Preset Speed 1 | As required (0-60 Hz) |
| 32 | Preset Speed 2 | Preset Speed 2 | As required (0-60 Hz) |
| 36 | Preset Speed 3 | Preset Speed 3 | As required (0-60 Hz) |

Preset speeds 2 & 3 are used only if required for two or three speed drives.

Parameter 50 contains the fault history of the last eight (8) faults with the most recent first. Pressing the “Mode” button three times will access this parameter.

Deceleration time: The deceleration time is factory set at 4 seconds. This can be adjusted to a shorter time period with the following warning. If the deceleration time is set to too short a time period, the drive controller will shut down and show an alarm. This is the result of the jib crane having too much inertia for the reducer and motor to stop in such a short time. If this occurs, increase the deceleration time.

WARNING

Do not remove or install the EPM module while power is applied to the drive controller. After removing power from the drive controller, wait three (3) minutes before removing the EPM module for the capacitors to discharge.

STEP 4 - LIMIT SWITCH INSTALLATION

If applicable, install limit switches per the following instructions and **diagram 4A** on page 8. The limit switches are designed to shut off the power to the rotation drive motor in a clockwise or counterclockwise direction and *are not intended to serve as a spotting function*.

Two limit switches are mounted on the channel attached to the main frame. Each switch has an adjustable roller-type lever arm and is actuated by a limit switch ramp that must be attached to the mast pipe. The limit switch ramps must be field located, by the installer, to shut off power at the desired clockwise and counterclockwise points. The switches (optional) are pre-wired into the control panel of the jib crane and require no additional electrical hook-up.

SWITCH ADJUSTMENT:

After the jib crane has been erected and the safety channel, with the two limit switches, has been installed, the switch set-up is as follows:

1. Loosen the hex socket screw that locks the adjustable lever arm in position.
2. Loosen the lock pin hex nut that fastens the lever arm assembly to the limit switch.
3. Rotate the lever arm until it is perpendicular to the face of the mast pipe and then rotate it an additional 15° away from the side that will contact the limit switch ramp (15° counterclockwise for the upper limit switch and 15° clockwise for the lower limit switch). The additional 15° will prevent jamming of the lever arm when the lever arm contacts the limit switch ramp.
4. Adjust the roller so that it has a 1/8" maximum clearance to the face of the mast pipe.
5. Retighten both the hex socket screw and the lock pin hex nut.
6. Rotate the jib crane 360° and check to see if the roller comes in contact with the mast pipe. If the roller contacts the mast pipe, increase the clearance between the roller and the pipe until it does not.
7. Repeat this procedure for the second limit switch.

STEP 4 - LIMIT SWITCH INSTALLATION (CONTINUED)

RAMP INSTALLATION:

Two rotation limits can be established, one in the clockwise direction and one in the counter-clockwise direction. The **lower** switch will be the **clockwise** rotation limit switch and the **upper** switch will be the **counterclockwise** rotation limit switch. **Do not reverse the functions of the upper and lower limit switches.** Reversing the functions may cause the limit switch lever arm to hit the limit switch mounting bracket.

Clockwise Rotation Limit Switch Ramp Installation:

1. Place the jib in its' clockwise limit position.
2. Position a limit switch ramp, with the beveled edge facing the switch lever arm roller, on the mast pipe to the left of the lower switch.
3. Slide the limit switch ramp along the surface of the mast pipe, into the roller lever arm causing the lever arm to move. Stop moving the ramp when an audible click is heard from the switch.
4. Drill and tap two (2) 1/4"-20 holes in the mast pipe centered in the two slots in the limit switch ramp.
5. Secure the limit switch ramp to the mast pipe using the (2) tapped holes and the 1/4"-20 hardware provided.
6. Adjust the limit switch ramp location to compensate for over travel (see the over travel adjustment instructions on page 8).

Counterclockwise Rotation Limit Switch Ramp Installation:

1. Place the jib in its' counterclockwise limit position.
2. Position a limit switch ramp, with the beveled edge facing the switch lever arm roller, on the mast pipe to the right of the upper switch.
3. Repeat Steps 3 through 6 from "Clockwise Rotation Limit Switch Ramp Installation" instructions.

STEP 4 - LIMIT SWITCH INSTALLATION (CONTINUED)

Over Travel Adjustment Instructions:

All cranes will experience some over travel, after power to the drive is shut off, due to inertia of the load acquired during rotation. The amount of over travel is dependent on the application and the size of the jib crane. In order to accurately compensate for over travel, it is necessary to test the rotation performance of the jib under full load and determine the actual over travel.

1. With the hoist at the end of the boom, lift a capacity load up one half the distance from the floor to the hoist.
2. Push the "ON" button to power controls.
3. Start rotating jib crane in the direction of the previously installed limit switch ramp. It is important to give the jib crane enough starting distance before the ramp to accelerate to full speed.
4. When the limit switch reaches the desired rotation limit position, the lever arm will contact the ramp and the power to the motor will be shut off. Allow the jib crane to come to a full stop.
5. Measure the distance between the beveled edge of the ramp and the centerline of the roller on the switch arm.
6. Loosen the 1/4"-20 hardware holding the limit switch ramp to the mast pipe and slide the ramp towards the lever arm roller the distance measured in Step 5.

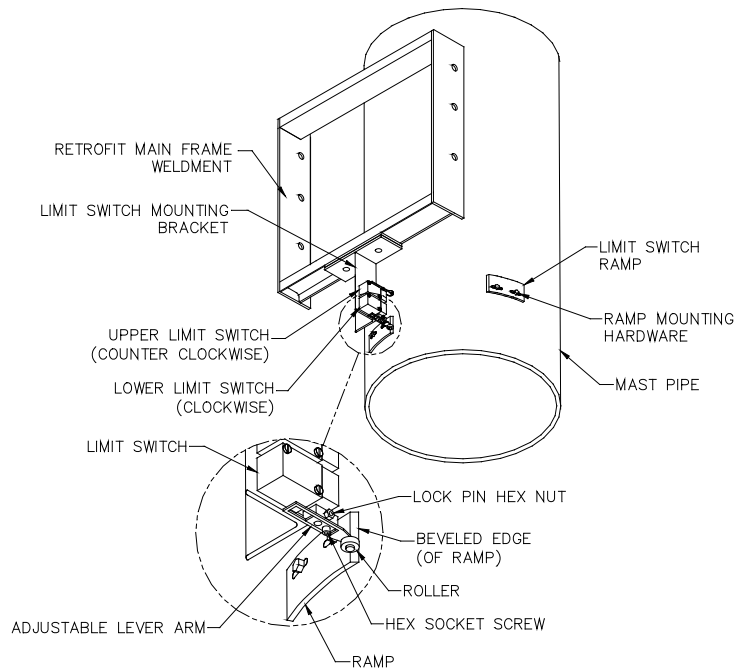

Diagram 4A. Limit Switch Installation

7. Retighten the 1/4"-20 hardware to hold the limit switch ramp into place on the mast pipe.

STEP 5 - ENDSTOP/TAGLINE INSTALLATION

Tagline Festoon Installation - Where Applicable (*diagram 5A*)

- 5.1 Bolt tagline bracket and an endstop to end of boom closest to the mast.
- 5.2 Reinstall existing hoist/hoist trolley into place (where applicable).
- 5.3 Immediately bolt remaining tagline bracket and endstop into place at the front of boom. Torque nuts.
- 5.4 Bolt eyebolts to tagline brackets using two hexnuts per eyebolt.
- 5.5 Loop the wire rope through one of the eyebolts and clamp the loop using cable clamps. Repeat this step at the other eyebolt while removing any slack from the wire rope.
- 5.6 Adjust the eyebolts to achieve the desired cable tension and lock the eyebolts in place by tightening the hexnuts.
- 5.7 Run the festoon cable through the S-hooks or wire rope trolleys (squeeze bottom of S-hooks to grip cable or hose).
- 5.8 Wire the hoist per manufacturer's (SIC) instructions.

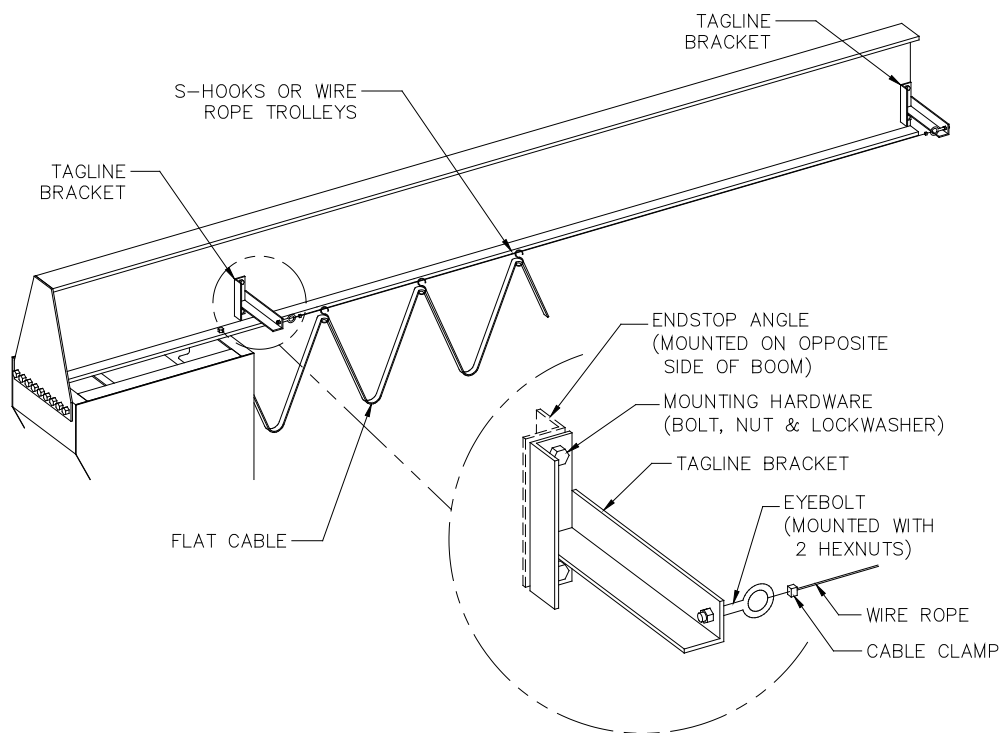

Diagram 5A. Tagline Festoon Installation.

STEP 6 - SHUT-DOWN INSTRUCTIONS

- 6.1 Secure the beam in shut-down position or storage area. Check crane, hoist and hook storage positions to be sure there is no interference with other pieces of equipment that may be operating in the area.
- 6.2 If crane is electrified, shut power OFF on pendant and disconnect switch. Make sure there are not any damaged wires and all of the connections are tight. Make a visual check before leaving area.

STEP 7 - FINAL STEPS

➡ **TIP:** Do not throw away this manual: maintenance schedule is on back cover.

- 7.1 Check to make sure all bolts are tightened and lockwashers are compressed.
- 7.2 If necessary, touch up with paint provided.
- 7.3 Keep Packing List, Installation Manual, General Arrangement Drawing and any other inserts together in a safe place.

SAFETY WARNINGS AND PRECAUTIONS

Safety is very important when operating a jib crane. There are many safety warnings and precautions the operator should be aware of. These include, but are not limited to, the following:

- The jib can only be used to pick up a **MAXIMUM** of **RATED CAPACITY**.
- The load will swing when lifted.
- Make sure the power is "**OFF**" prior to doing any electrical work or checking wires and connections.
- When loading, pick load directly up. Crane should not be used to pick up a load diagonally or out of the range of the span.
- On all baseplate mounted cranes, periodically check anchor bolts to make sure they are tight.
- Watch for wet spots: oil, water, etc. where the operator may slip.
- Check that all bolts are tight and have lockwashers.
- Make sure endstops are in place, are fully engaging the trolley and the endstop hardware is tight.
- Make sure that festooning cannot be snagged or pinched.
- Check for obstructions in crane travel.
- The operator should have full concentration on the crane and its surroundings at all times.

TROUBLESHOOTING GUIDE

| PROBLEM | CHECK | YES | NO |
|-----------------------------------|---|-----------|--|
| Jib does not rotate | 1. Is AC contactor coil pulling in when ON is pressed and does it stay in? | See No. 3 | Check fuses in jib panel. Check Pendant wiring. Check control transformer fuse. |
| | 2. Is motor shaft turning? (With TEFC motors, if fan is blowing, air motor shaft is turning.) | See No. 4 | Check that motor leads are secure. Check thermal overloads on reversing starter. |
| | 3. Are reversing starter coils pulling in when "CW" or "CCW" buttons are pressed? | See No. 2 | Check pendant wiring. |
| | 4. Are the drive rollers turning? | See No. 5 | Readjust rollers for correct contact. |
| | 5. Call factory and ask for Customer Service. | | |
| Jib rotates in one direction only | 1. Are reversing starter coils pulling in when "CW" or "CCW" buttons are pressed? | See No. 2 | Check pendant wiring. |
| | 2. Call factory and ask for Customer Service. | | |

If you are experiencing any other problems in the start-up or operation of your Gorbel® crane, please call 1-800-821-0086 and ask for Customer Service.

TRUNNION ROLLER REPLACEMENT

WARNING

Note: Only competent personnel familiar with standard fabrication procedures should be allowed to perform maintenance operations to Gorbel® systems. Power to drive assembly should be disconnected before performing any maintenance procedures.

NOTE: Gorbel® Trunnion Rollers are an overmolded assembly to be replaced as an entire unit. Follow instructions below:

- Back off hexnuts on spring tensioners to release Trunnion Roller contact against mast face (reference *diagrams 2A* and *2B* on page 3).
- Main frame and drive assembly should be adequately supported and power to motor disconnected before proceeding.
- Remove pivot rod and related hardware from spring tension frame.
- Remove drive mounting frame.
- Remove chain from drive sprockets and drive roller.
- Remove cotter pins that retain trunnion roller shafts.
- Remove trunnion rollers from drive mounting frame and replace with new assembly.
- Re-assemble in reverse order as above and check hardware torque specs.

NOTE: Gorbel® Trunnion Rollers should be lubricated prior to operation.

CRANE OPERATOR INSTRUCTIONS

TIP: Be sure your installers, maintenance personnel, and operators realize this jib can only be used to pick up a maximum of its rated capacity.

Overhead cranes and jib cranes generally handle materials over working areas where there are personnel. Therefore, it is important for the Crane Operator to be instructed in the use of the crane and to understand the severe consequences of careless operation.

It is not intended that these suggestions take precedence over existing plant safety rules and regulations or OSHA regulations. However, a thorough study of the following information should provide a better understanding of safe operation and afford a greater margin of safety for people and machinery on the plant floor. It must be recognized that these are suggestions for the Crane Operator's use. It is the responsibility of the owner to make personnel aware of all federal, state and local rules and codes, and to make certain operators are properly trained.

Qualifications

Crane operation, to be safe and efficient, requires skill: the exercise of extreme care and good judgment, alertness and concentration, and rigid adherence to proven safety rules and practices as outlined in applicable and current ANSI and OSHA safety standards. In general practice, no person should be permitted to operate a crane:

- Who cannot speak the appropriate language or read and understand the printed instructions.
- Who is not of legal age to operate this type of equipment.
- Whose hearing or eyesight is impaired (unless suitably corrected with good depth perception).
- Who may be suffering from heart or other ailments which might interfere with the operator's safe performance.
- Unless the operator has carefully read and studied this operation manual.
- Unless the operator has been properly instructed.
- Unless the operator has demonstrated his instructions through practical operation.
- Unless the operator is familiar with hitching equipment and safe hitching equipment practices.

Handling the Jib Boom Motion

Before using the boom of the jib crane, the operator should be sure the hook is high enough to clear any obstruction. Before a load is handled by the crane, the jib boom should be brought into position so that it is directly over the load. Start the jib boom slowly and bring it up to speed gradually. Approaching the place where it is desired to stop the jib, reduce the boom speed.

Handling the Trolley Motion

Before a load is handled, the hoist should be positioned directly over the load that is to be handled. When the slack is taken out of the slings, if the hoist is not directly over the load, bring it directly over the load before hoisting is continued. Failure to center the hoist over the load may cause the load to swing upon lifting. Always start the trolley motion slowly and reduce the trolley speed gradually.

Handling the Hoist Motion

Refer to the lifting (hoist) equipment's operating instructions.

GENERAL SUGGESTIONS

Know Your Crane

Crane operators should be familiar with the principal parts of a crane and have a thorough knowledge of crane control functions and movements. The crane operator should be required to know the location and proper operation of the main conductor disconnecting means for all power to the attachments on the crane.

Responsibility

Each crane operator should be held directly responsible for the safe operation of the crane. Whenever there is any doubt as to SAFETY, the crane operator should stop the crane and refuse to handle loads until: (1) safety has been assured or (2) the operator has been ordered to proceed by the supervisor, who then assumes all responsibility for the SAFETY of the lift.

Do not permit **ANYONE** to ride on the hook or a load.

Inspection

Test the crane movement and any attachments on the crane at the beginning of each shift. Whenever the operator finds anything wrong or apparently wrong, the problem should be reported immediately to the proper supervisor and appropriate corrective action taken.

Operating Suggestions

One measure of a good crane operator is the smoothness of the crane operation. The good crane operator should **know** and follow these proven suggestions for safe, efficient crane handling.

1. The crane should be moved smoothly and gradually to avoid abrupt, jerky movements of the load. Slack must be removed from the sling and hoisting ropes before the load is lifted.
2. Center the crane over the load before starting the hoist to avoid swinging the load as the lift is started. Loads should not be swung by the crane to reach areas not under the crane.
3. Crane-hoisting ropes should be kept vertical. Cranes **shall not** be used for side pulls.
4. Be sure everyone in the immediate area is clear of the load and aware that a load is being moved.
5. Do not make lifts beyond the rated load capacity of the crane, sling chains, rope slings, etc.
6. Make certain that before moving the load, load slings, load chains, or other lifting devices are fully seated in the saddle of the hook with hook latch closed (if equipped with hook latch).
7. Check to be sure that the load and/or bottom block is lifted high enough to clear all obstructions when moving boom or trolley.
8. At no time should a load be left suspended from the crane unless the operator has the push button with the power on, and under this condition keep the load as close as possible to the floor to minimize the possibility of an injury if the load should drop. When the crane is holding a load, the crane operator should remain at the push button.
9. Do not lift loads with sling hooks hanging loose. If all sling hooks are not needed, they should be properly stored, or use a different sling.
10. All slings or cables should be removed from the crane hooks when not in use (dangling cables or hooks hung in sling rings can inadvertently snag other objects when the crane is moving).
11. Operators shall not carry loads and/or empty bottom blocks over personnel. Particular additional caution should be practiced when using magnet or vacuum devices. Loads, or parts of loads, held magnetically could drop. Failure to power magnets or vacuum devices can result in dropping the load. Extra precaution should be exercised when handling molten metal in the proximity of personnel.
12. Whenever the operator leaves the crane the following procedure should be followed:
 - Raise all hooks to an intermediate position.
 - Spot the crane at an approved designated location.
 - Place all controls in the "off" position.
 - Open the main switch to the "off" position.
 - Make visual check before leaving the crane.
13. In case of emergency or during inspection, repairing, cleaning or lubrication, a warning sign or signal should be displayed and the main switch should be locked in the "off" position. This should be done whether the work is being done by the crane operator or by others.
14. Contact with rotation stops or trolley end stops shall be made with extreme caution. The operator should do so with particular care for the safety of persons below the crane, and only after making certain that any persons on the other cranes are aware of what is being done.
15. ANY SAFETY FEATURES AND MECHANISMS BUILT-IN OR OTHERWISE PROVIDED WITH THE CRANE BY GORBEL ARE REQUIRED FOR THE SAFE OPERATION OF THE CRANE. DO NOT, UNDER ANY CIRCUMSTANCES, REMOVE OR OTHERWISE IMPAIR OR DISABLE THE PROPER FUNCTIONING OF ANY CRANE SAFETY MECHANISMS OR FEATURES BUILT-IN OR OTHERWISE PROVIDED BY GORBEL FOR SAFE OPERATION OF THE CRANE. ANY REMOVAL, IMPAIRMENT OR DISABLING OF ANY SUCH SAFETY MECHANISMS OR FEATURES OR OTHER USE OR OPERATION OF THE CRANE WITHOUT THE COMPLETE AND PROPER FUNCTIONING OF ANY SUCH SAFETY MECHANISMS OR FEATURES AUTOMATICALLY AND IMMEDIATELY VOIDS ANY AND ALL EXPRESS AND IMPLIED WARRANTIES OF ANY KIND OR NATURE.

LIMITED WARRANTY

It is agreed that the equipment purchased hereunder is subject to the following LIMITED warranty and no other. Gorbel Incorporated ("Gorbel") warrants the manual push-pull Work Station Cranes, Jib Crane, and Gantry Crane products to be free from defects in material or workmanship for a period of ten years or 20,000 hours use from date of shipment. Gorbel warrants the Motorized Work Station Cranes and Jib Crane products to be free from defects in material or workmanship for a period of two years or 4,000 hours use from the date of shipment. Gorbel warrants the G-Force® and Easy Arm™ products to be free from defects in material or workmanship for a period of one year or 2,000 hours use from the date of shipment. This warranty does not cover Gantry Crane wheels. This warranty shall not cover failure or defective operation caused by operation in excess of recommended capacities, misuses, negligence or accident, and alteration or repair not authorized by Gorbel. No system shall be field modified after manufacture without the written authorization of Gorbel, Inc. Any field modification made to the system without the written authorization of Gorbel, Inc. shall void Gorbel's warranty obligation. OTHER THAN AS SET FORTH HEREIN, NO OTHER EXPRESS WARRANTIES, AND NO IMPLIED WARRANTIES, ORAL OR WRITTEN, INCLUDING BUT NOT LIMITED TO THE WARRANTIES OF MERCHANTABILITY OR FITNESS FOR PARTICULAR PURPOSE, ARE MADE BY GORBEL WITH RESPECT TO ITS PRODUCTS AND ALL SUCH WARRANTIES ARE HEREBY SPECIFICALLY DISCLAIMED. GORBEL SHALL NOT BE LIABLE UNDER ANY CIRCUMSTANCES FOR ANY INCIDENTAL, SPECIAL AND/OR CONSEQUENTIAL DAMAGES WHATSOEVER, WHETHER OR NOT FORESEEABLE, INCLUDING BUT NOT LIMITED TO DAMAGES FOR LOST PROFITS AND ALL SUCH INCIDENTAL, SPECIAL AND/OR CONSEQUENTIAL DAMAGES ARE HEREBY ALSO SPECIFICALLY DISCLAIMED. Gorbel's obligation and Purchaser's or end user's sole remedy under this warranty is limited to the replacement or repair of Gorbel's products at the factory, or at the discretion of Gorbel, at a location designated by Gorbel. Purchaser or end user shall be solely responsible for all freight and transportation costs incurred in connection with any warranty work provided by Gorbel hereunder. Gorbel will not be liable for any loss, injury or damage to persons or property, nor for damages of any kind resulting from failure or defective operation of any materials or equipment furnished hereunder. Components and accessories not manufactured by Gorbel are not included in this warranty. Purchaser's or end user's remedy for components and accessories not manufactured by Gorbel is limited to and determined by the terms and conditions of the warranty provided by the respective manufacturers of such components and accessories.

A) DISCLAIMER OF IMPLIED WARRANTY OF MERCHANTABILITY

Gorbel and Purchaser agree that any claim made by Purchaser which is inconsistent with Gorbel's obligations and the warranty remedies provided with Gorbel's products, and in particular, special, incidental and consequential damages, are expressly excluded.

B) DISCLAIMER OF IMPLIED WARRANTY OF FITNESS FOR PARTICULAR PURPOSE

Gorbel and Purchaser agree that the implied warranty of fitness for particular purpose is excluded from this transaction and shall not apply to the goods involved in this transaction.

C) DISCLAIMER OF EXPRESS WARRANTY

Gorbel's agents, or dealer's agents, or distributor's agents may have made oral statements about the machinery and equipment described in this transaction. Such statements do not constitute warranties, and Purchaser agrees not to rely on such statements. Purchaser also agrees that such statements are not part of this transaction.

D) DISCLAIMER OF SPECIAL, INCIDENTAL AND CONSEQUENTIAL DAMAGES

Gorbel and Purchaser agree that any claim made by Purchaser which is inconsistent with Gorbel's obligations and the warranty remedies provided with Gorbel's products, and in particular, special, incidental and consequential damages, are expressly excluded.

E) DEALER OR DISTRIBUTOR NOT AN AGENT

Gorbel and Purchaser agree that Purchaser has been put on notice that dealer or distributor is not Gorbel's agent in any respect for any reason. Gorbel and Purchaser also agree that Purchaser has been put on notice that dealer or distributor is not authorized to incur any obligations or to make any representations or warranties on Gorbel's behalf other than those specifically set forth in Gorbel's warranty provided in connection with its product.

F) MERGER

This warranty agreement constitutes a final and complete written expression of all the terms and conditions of this warranty and is a complete and exclusive statement of those terms.

G) PAINTING

Every crane (excluding components) receives a quality paint job before leaving the factory. Unfortunately, no paint will protect against the abuses received during the transportation process via common carrier. We have included at least one (1) twelve ounce spray can for touchup with each crane ordered (unless special paint was specified). If additional paint is required, contact a Gorbel® Customer Service Representative at 1-800-821-0086 or 1-585-924-6262.

Title and Ownership:

Title to the machinery and equipment described in the foregoing proposal shall remain with Gorbel and shall not pass to the Purchaser until the full amount herein agreed to be paid has been fully paid in cash.

Claims and Damages:

Unless expressly stated in writing, goods and equipment shall be at Purchaser's risk on and after Seller's delivery in good shipping order to the Carrier. Gorbel shall in no event be held responsible for materials furnished or work performed by any person other than it or its authorized representative or agent.

Cancellations:

If it becomes necessary for the purchaser to cancel this order wholly or in part, he shall at once so advise Gorbel in writing. Upon receipt of such written notice all work will stop immediately. If the order entails only stock items, a flat restocking charge of 15% of the purchase price will become due and payable by Purchaser to Gorbel. Items purchased specifically for the canceled order shall be charged for in accordance with the cancellation charges of our supplier plus 15% for handling in our factory. The cost of material and/or labor expended in general fabrication for the order shall be charged for on the basis of total costs to Gorbel up to the time of cancellation plus 15%.

Returns:

No equipment, materials or parts may be returned to Gorbel without express permission in writing to do so.

Extra Charge Delay: If Purchaser delays or interrupts progress of Seller's performance, or causes changes to be made, Purchaser agrees to reimburse Gorbel for expense, if any, incident to such delay.

Changes and Alterations:

Gorbel reserves the right to make changes in the details of construction of the equipment, as in its judgment, will be in the interest of the Purchaser; will make any changes in or additions to the equipment which may be agreed upon in writing by the Purchaser; and Gorbel is not obligated to make such changes in products previously sold any customer.

Third Party Action:

Should Gorbel have to resort to third party action to collect any amount due after thirty (30) days from date of invoice, the Purchaser agrees to pay collection costs, reasonable attorney's fees, court costs and legal interest.

OSHA Responsibilities:

Gorbel agrees to fully cooperate with Purchaser in the design, manufacture or procurement of safety features or devices that comply with OSHA regulations. In the event additional equipment or labor shall be furnished by Gorbel, it will be at prices and standard rates then in effect, or as may be mutually agreed upon at the time of the additional installation.

Equal Employment Opportunity:

Gorbel agrees to take affirmative action to ensure equal employment opportunity for all job applicants and employees without regard to race, color, age, religion, sex, national origin, handicap, veteran, or marital status. Gorbel agrees to maintain non-segregated work facilities and comply with rules and regulations of the Secretary of Labor or as otherwise provided by law or Executive Order.

MAINTENANCE SCHEDULE

| MAINTENANCE | | FREQUENCY* |
|--------------------|--|------------|
| Lubrication | See Lubrication Schedule below. | |
| Adjustments | <u>Check:</u> <ul style="list-style-type: none"> Level of boom Electrification system (be sure the power is OFF when checking wires and connections) All hardware is tight and in place. Proper chain tension | 3 months |
| Inspection | Perform general inspection | 6 months |

* Federal, state and local codes may require inspection and maintenance checks more often. Please check the state and local code manuals in your area.

LUBRICATION SCHEDULE

| COMPONENT | LUBRICANT | FREQUENCY* |
|---------------------------------|--|---|
| Drive chain | Kendall SR-12X open gear dipper stick and wire rope lubricant | Monthly |
| Trunnion roller bearings | Hi-pressure bearing grease Lubriplate #630-2 multi-purpose grease | N/A: Factory lubricated |
| Worm gear reducer | AGMA Standard #8 compound <u>Different manufacturers:</u> <ul style="list-style-type: none"> City Service Co. CITGO Oil #680-7 Chevron - NL Gear Comp. #680 Sun Oil Corp. - SUNEPA #1150 Texaco Inc. - Honor Cyl. Oil #680 Gulf Oil Corp. - Transgear #EP680 Shell Oil Corp. - Omala #680 Friske Brothers Refining - CP Gear Oil #8 Keystone Division - #K-600 Mobil Oil Corp. - Mobil #600W Super American Lube Inc. - AGMA #8 | <u>1st Lube:</u> After 250 hours of operation <u>Regularly:</u> 3 months |

Above is the suggested schedule. Be sure to always use recommended grade lubricants. For hoist and trolley maintenance, consult manufacturer's maintenance instructions and lubrication schedule.

* Federal, state and local codes may require inspection and maintenance checks more often. Please check the state and local code manuals in your area.

WARNING

Any changes in rolling effort, rotation effort or unusual noises must be immediately identified and corrected.

GORBEL[®]
A CLASS ABOVE

600 Fishers Run, P.O. Box 593
Fishers, NY 14453-0593
Telephone: (800) 821-0086
(585) 924-6262
Fax: (800) 828-1808
E-Mail: info@gorbel.com
http://www.gorbel.com

© 2010 Gorbel Inc.
All Rights Reserved

 **LinkedIn**
linkedin.com/company/gorbel

 **Facebook**
facebook.com/gorbelinc

 **YouTube**
youtube.com/gorbelmarketing

 **Twitter**
twitter.com/gorbelinc

 **gorbel.com/blog**