

Installation, Operation, & Maintenance Manual

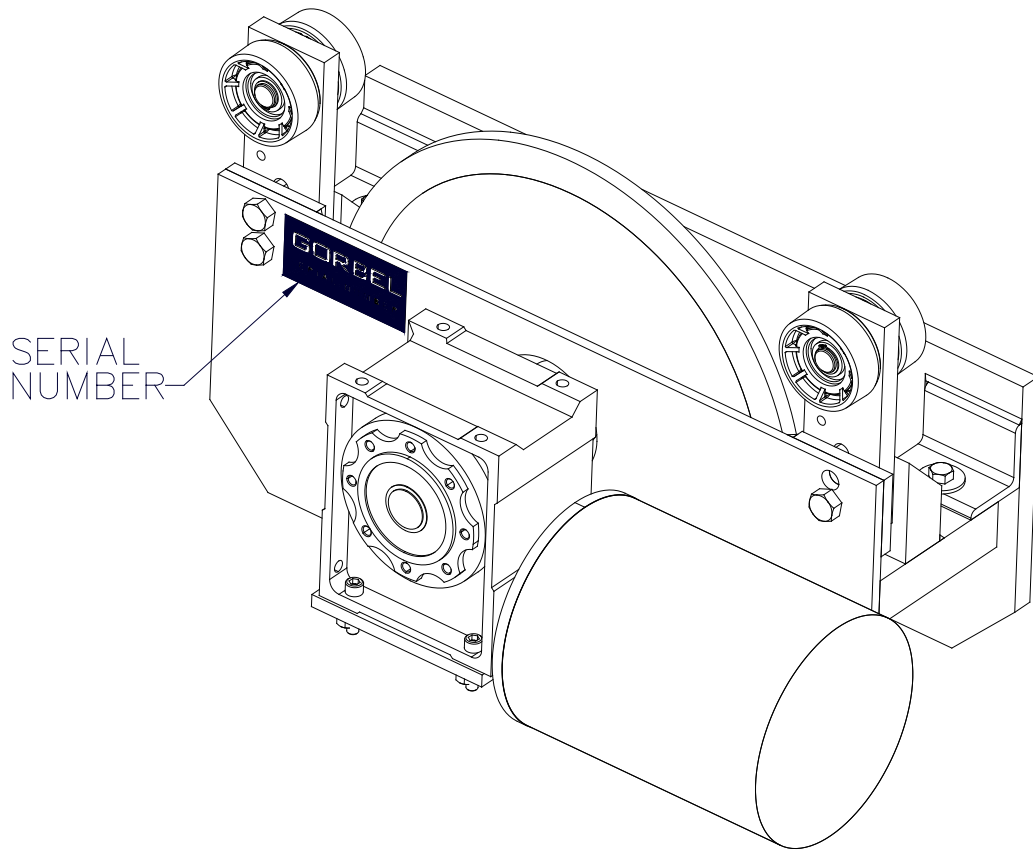

**IMPORTANT!
DO NOT DESTROY**

Work Station Crane Tractor Drive

Gorbel® Customer Order No. / Serial No. _____

Gorbel® Dealer _____

Date _____
Month Year

TABLE OF CONTENTS

Introduction.....	1
Installation	
Step 1 - Pre-Assembly	2
Step 2 - Verify Tractor Drive Assembly	2
Step 3 - End Truck/Hoist Trolley Bracket Installation.....	3
Step 4 - Tractor Drive Installation and Leveling	4
Step 5 - Drive Wheel Adjustment	5
Step 6 - End Truck/Hoist Trolley to Tractor Drive Connection.....	5
Step 7 - Tractor Drive Motor Controller(s).....	6-7
Trouble Shooting Guide	7
Hardware Torque Chart.....	7
Crane Operator Instructions	8
General Safety Requirements	8
Limited Warranty	9
Inspection and Maintenance Schedule	10
Specifications, Drawings & Literature (Inserted in this manual when applicable)	
Specification Sheet	
General Arrangement Drawing	
Electrical Schematic	
Pendant Wiring Schematic	
Tractor Drive Detail Drawing	
Wiring Layout Drawing	
Enclosure Mounting Detail	

Questions? Concerns? Comments? Please call (800) 821-0086 (US and Canada) or (585) 924-6262 (outside US).

INTRODUCTION

Thank you for choosing Gorbel® Work Station Crane Tractor Drives to solve your material handling needs. The innovative design and heavy duty construction of the Gorbel® Tractor Drive will provide a superior quality product that will offer years of long term value. Gorbel® Work Station Crane Tractor Drives will provide many years of dependable service by following the installation and maintenance procedures described herein.

Normal safety precautions: These include, but are not limited to:

- Checking for obstructions in crane travel
- Checking that all bolts and threaded rods are tight and have lock washers
- Making sure that end stops are in place
- Making sure that festooning cannot be snagged or pinched, whether it is electric or pneumatic

For additional safety precautions, see page 8.

WARNING

Equipment described herein is not designed for, and should not be used for, lifting, supporting, or transporting humans. Failure to comply with any one of the limitations noted herein can result in serious bodily injury and/or property damage. Check State and Local regulations for any additional requirements.

WARNING

Crane cannot be utilized as a ground: A separate ground wire is required. For example, systems with three phase power require three conductors plus one ground wire.

WARNING

Reference the American Institute of Steel Construction (AISC) Manual of Steel Construction, Specification for Structural Joints using ASTM A325 or A490 Bolts for the proper procedures to follow when using any torque-tightening method.

INSTALLATION

STEP 1 - PRE-ASSEMBLY

➡ **TIP:** Packing list can be found in plastic sleeve in hardware box: Tractor Drive General Arrangement Drawing and additional literature can be found enclosed in this installation manual.

Read entire installation manual **before** you begin installing your tractor drive.

- 1.1 Check packing list to make sure **correct quantity** of parts is included.
- 1.2 Tools and materials (by others) typically needed to assemble tractor drive are as follow:
 - Hand tools
 - Ladders/man lifts
 - Torque wrench (able to torque up to 30 ft.-lb.)

STEP 2 - VERIFY THE TRACTOR DRIVE ASSEMBLY

- 2.1 Apply a straight edge between single wheel trolley plates and verify the drive wheel is parallel to this straight edge (**diagram 2A**). If adjustment is required, loosen the reducer mounting screws, adjust the drive wheel alignment and torque the reducer mounting hardware per the torque chart on page 7.
- 2.2 Verify adjustment single wheel trolley is mounted to the frame in the correct hole for your track series. Mounting hardware should be in the lower hole for 2000 and 4000 series track as shown in **diagram 2B**. For 1000 series track, the mounting hardware should be in the upper hole. Correct if required.

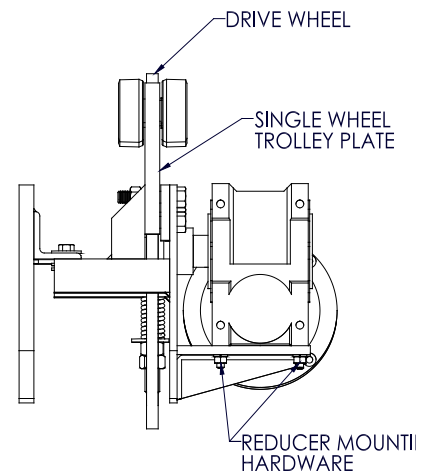

Diagram 2A. Drive Wheel Alignment.

CAUTION
If adjustment single wheel trolley is mounted in wrong hole, drive wheel could slip or bind.

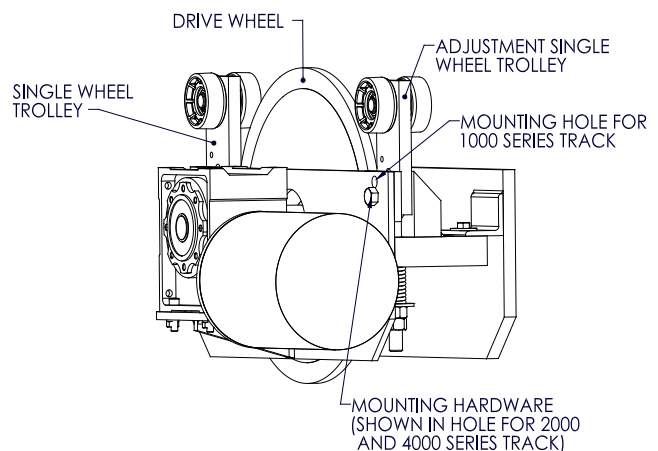

Diagram 2B. Adjustment Single Wheel Trolley Mounting.

STEP 3 - END TRUCK/TROLLEY BRACKET INSTALLATION

TIP: Note the orientation of the wheels prior to disassembly so that they can be reinstalled properly.

3.1 Remove the two wheels on the end of the hoist trolley on which you are going to mount the tractor drive bracket. The wheels are held onto the axle by retaining rings. Keep the retaining rings to reassemble the wheels after mounting the bracket. Removal of the wheels should not be required when mounting the bracket to an end truck.

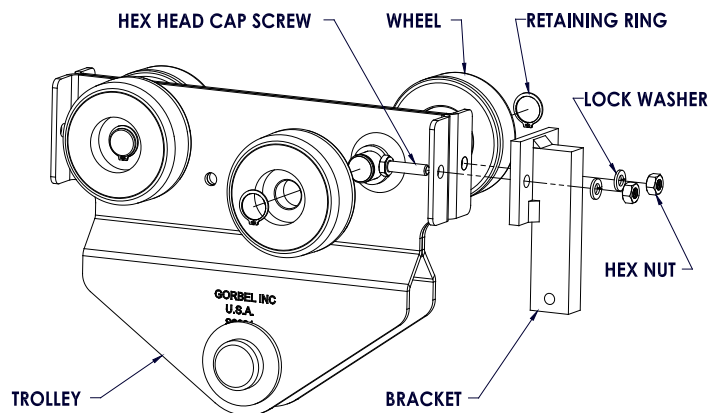

Diagram 3A. Hoist Trolley/End Truck Bracket Mounting.

3.2 Align the mounting holes of the End Truck/Trolley Bracket with the mating holes in the the hoist trolley/end truck. Ensure the bracket is in the orientation shown in **Diagram 3A**.

3.3 Install the mounting hardware furnished and torque per the torque code chart on page 7.

3.4 Reassemble the two wheels onto the axles and reinstall in the retaining rings. Use caution to ensure that the wheels are assembled in the same orientation as the two wheels which are already on the hoist trolley. Ensure that the retaining rings are fully seated in the grooves on the axles.

Extended End Trucks

3.5 If field installing a tractor drive to an existing extended end truck, 13/32" diameter holes are required. Drill holes, as shown in **diagram 3B**, 1" from end of extension tube for 2" wide tubes (1000 series) and 1-1/2" from end for 3" wide tubes (2000 and 4000 series).

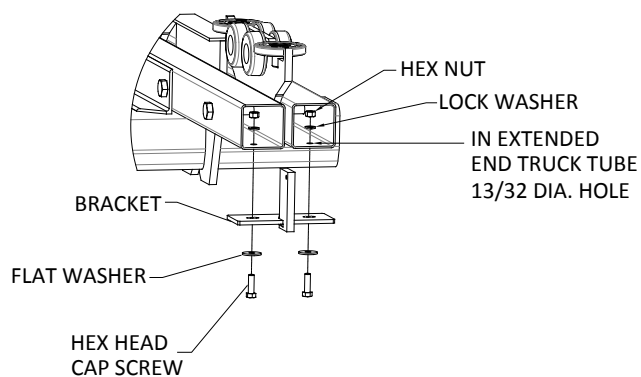

Diagram 3B. Extended End Truck Mounting Bracket.

3.6 Align the mounting holes of the extended end truck bracket with the mating holes in the extended end truck extension tubes. Ensure the bracket is in the orientation shown in **diagram 3B**.

3.7 Install the mounting hardware and torque per the torque code chart on page 7.

STEP 4 - TRACTOR DRIVE INSTALLATION AND LEVELING

WARNING

Use caution to support the counterweight during adjustment.

4.1 Install the tractor drive assembly single wheel trolleys into the enclosed track. Ensure that the tractor drive is facing the hoist trolley/end truck bracket as shown.

4.2 Allow the tractor drive assembly to hang down from the track. The drive wheel should not be in contact with the track at this time.

4.3 Loosen (do not remove) the hardware that holds the counterweight as indicated in **diagram 4A**. Use caution to support the counterweight during adjustment.

4.4 Slide the counterweight in or out until the tractor drive frame hangs level from the track. An equal force applied horizontally to each side of the drive wheel causes the same angle of tilt. The counterweight factory setting is all the way out.

4.5 Once adjusted, retighten the counterweight mounting hardware and torque per the torque chart on page 7.

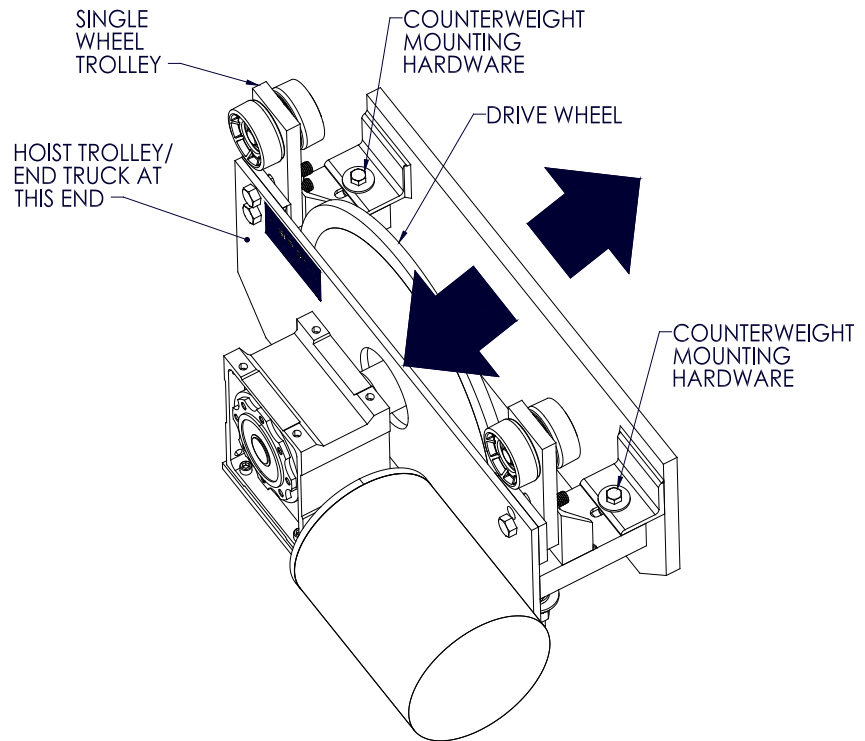

Diagram 4A. Installation and Leveling of Tractor Drive.

STEP 5 - DRIVE WHEEL ADJUSTMENT

➡ **TIP:** The drive wheel pressure can be adjusted to compensate for wheel wear or slippage due to severe applications.

WARNING

Use caution to support the tractor drive prior to adjusting the drive wheel pressure.

- 5.1 Prior to adjusting the drive wheel, push the tractor drive unit along the track checking to ensure that there are no obstructions. The drive wheel should not yet be contacting the track.
- 5.2 Loosen the jam nut on the adjustment single wheel trolley threaded rod. See **diagram 5A**.
- 5.3 Tighten the first hex nut on the threaded rod, against the washer and the spring, so that the drive wheel is just starting to contact the track. The drive wheel will contact the underside of the top surface of the track.
- 5.4 Tighten the first hex nut an additional (6) turns. Additional tightening may be required for severe applications or over time to compensate for component wear.
- 5.5 Tighten the jam nut against the first hex nut locking the first hex nut in position. Hold the hex nut in position while tightening the jam nut to prevent the hex nut from rotating.

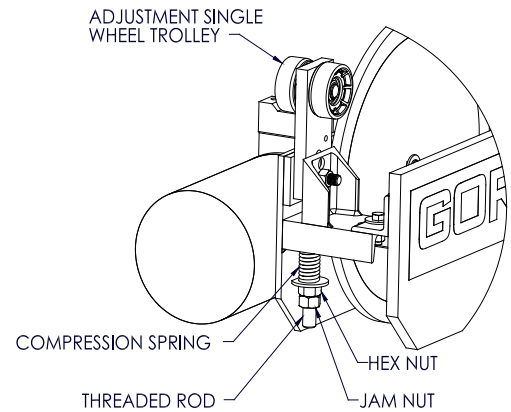

Diagram 5A. Drive Wheel Adjustment.

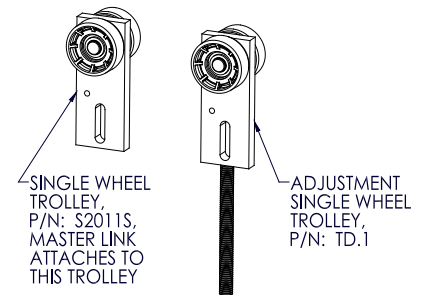

Diagram 5B. Single Wheel Trolley Difference.

Note: If having trouble getting the proper adjustment, refer to Step 2 and verify mounting position of adjustment trolley.

STEP 6 - END TRUCK/TROLLEY TO TRACTOR DRIVE CONNECTION

- 6.1 Carefully roll the end truck/hoist trolley up to tractor drive unit. Use caution not to let the two collide.
- 6.2 Position the hole in the hoist trolley/end truck bracket with the hole in the tractor drive single wheel trolley as shown in **diagram 6A**.
- 6.3 Slide the pin portion of the master link into the holes as shown in **diagram 6A**. Slide the side plate onto the master link pins and secure with cotter pins.

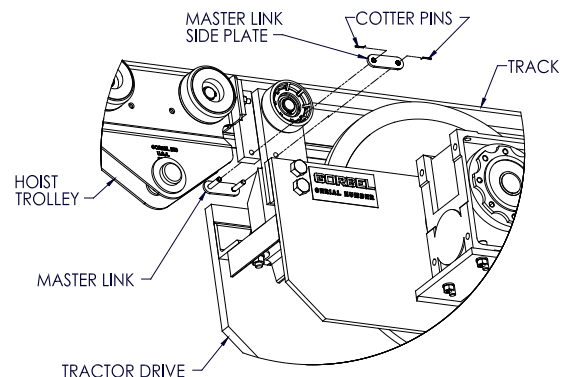

Diagram 6A. Link Pin Installation.

Note: Part number TDM.LINK includes master link, master link side plate and cotter pins.

STEP 7 - TRACTOR DRIVE MOTOR CONTROLLER(S)

The drive controller(s) for the Tractor Drives are pre-programmed at Gorbel for variable speed (VFD) operation. For trouble shooting and general information, a brief summary of how the drive controller(s) are designed to be used is included below. No additional programming is required.

WARNING

The drive controller must only operate on its own control voltage and not be connected to an external voltage source. Allowing 24 or 120 voltage to go through the drive will **PERMANENTLY DAMAGE** the internal controls!

VFD - ONE, TWO OR THREE SPEED OPTION

The motor speed is varied to determine the desired tractor drive speed. The reducer ratio used is that for the fastest speed: 120 fpm. The drive controller(s) are then programmed for the motor to operate at one, two or three different percentages of full speed based on the desired speeds specified by the customer at the time the order is placed.

Note: The VFD consists of pre-set speeds, it is not infinitely variable during use.

DRIVE CONTROLLER PROGRAMMING

Gorbel pre-programs a number of parameters in the drive controller prior to shipment. The remaining parameters are left at the factory default settings. All parameters are stored on the EPM module. These parameters are as follows:

Parameter #	Name	New Value
1	Line Voltage	High or Low (see manual)
4	Stop Method	Ramp to stop
5	Standard Speed Source	Preset speed
10	TB-13A Function Select	Run reverse
11	TB-13B Function Select	Preset speed
12	TB-13C Function Select	Preset speed
17	Rotation	Forward and Reverse
19	Acceleration	5 seconds
20	Deceleration	3 seconds
23	Minimum Frequency	0 Hz
24	Maximum Frequency	60 Hz
26	Motor Overload	As required (see manual)
31	Preset Speed 1	As required (0-60 Hz)
32	Preset Speed 2	As required (0-60 Hz)
36	Preset Speed 3	As required (0-60 Hz)

Parameter 50 contains the fault history of the last eight (8) faults with the most recent first. Pressing the "Mode" button three times will access this parameter (see Variable Frequency Drive Manual).

STEP 7 - TRACTOR DRIVE MOTOR CONTROLLER(S) (CONTINUED)

Deceleration time: The deceleration time is factory set at 3 seconds. This can be adjusted to a shorter time period with the following warning. If the deceleration time is set to too short a time period, the drive controller will shut down and show an alarm. This is the result of the bridge or trolley having too much inertia for the reducer and motor to stop in such a short time. If this occurs, increase the deceleration time.

WARNING

Do not remove or install the EPM module while power is applied to the drive controller. After removing power to the drive controller, wait three (3) minutes before removing the EPM module for the capacitors to discharge.

TROUBLE SHOOTING GUIDE

PROBLEM	CHECK	YES	NO
Tractor does not drive	1. Is the AC contactor coil pulling in when ON is pressed and does it stay in?	See No. 2	Check fuses in panel. Check pendant wiring. Check control transformer fuse. Check that drive is not showing an alarm.
	2. Is the motor shaft turning?	See No. 3	Check that motor leads are secure. Check thermal overloads.
	3. Is the drive wheel pressure adjusted properly?	See No. 4	Adjust the drive wheel pressure per the instructions on page 4.
	4. Is the EPM module installed in the drive controller?	See No. 5	Install the EPM module and ensure that it is completely seated in the drive unit.
	5. Is the drive controller showing an error code?	See No. 6 and note the error.	Refer to drive manual.
	6. Call factory and ask for Customer Service.		

If you are experiencing any other problems in the start-up or operation of your **Gorbel®** crane please call (800) 821-0086.

HARDWARE TORQUE CHART

HARDWARE SIZE	TORQUE
1/4"-20	6-1/3 ft.-lbs.
5/16"-18	13 ft.-lbs.
3/8"-16	23 ft.-lbs.
M10 x 1.5	30 ft.-lbs.

CRANE OPERATOR INSTRUCTIONS

Overhead cranes and jib cranes generally handle materials over working areas where there are personnel. Therefore, it is important for the Crane Operator to be instructed in the use of the crane and to understand the severe consequences of careless operation. It is not intended that these suggestions take precedence over existing plant safety rules and regulations or OSHA regulations. However, a thorough study of the following information should provide a better understanding of safe operation and afford a greater margin of safety for people and machinery on the plant floor. It must be recognized that these are suggestions for the Crane Operator's use. It is the responsibility of the owner to make personnel aware of all federal, state and local rules and codes, and to make certain operators are properly trained.

Qualifications

Crane operation, to be safe and efficient, requires skill: the exercise of extreme care and good judgment, alertness and concentration, and rigid adherence to proven safety rules and practices as outlined in applicable and current ANSI and OSHA safety standards. In general practice, no person should be permitted to operate a crane:

- Who cannot speak the appropriate language or read and understand the printed instructions.
- Who is not of legal age to operate this type of equipment.
- Whose hearing or eyesight is impaired (unless suitably corrected with good depth perception).
- Who may be suffering from heart or other ailments which might interfere with the operator's safe performance.
- Unless the operator has carefully read and studied this operation manual.
- Unless the operator has been properly instructed.
- Unless the operator has demonstrated his instructions through practical operation.
- Unless the operator is familiar with hitching equipment and safe hitching equipment practices.

Handling the Bridge Travel Motion

Before using the bridge of the crane, the operator should be sure the hook is high enough to clear any obstruction. Before a load is handled by the crane, the bridge should be brought into position so that it is directly over the load. Start the bridge slowly and bring it up to speed gradually. Approaching the place where it is desired to stop the bridge, reduce the bridge speed.

Handling the Trolley Motion

Before a load is handled, the hoist should be positioned directly over the load that is to be handled. When the slack is taken out of the slings, if the hoist is not directly over the load, bring it directly over the load before hoisting is continued. Failure to center the hoist over the load may cause the load to swing upon lifting. Always start the trolley motion slowly and reduce the trolley speed gradually.

Handling the Hoist Motion

Refer to the lifting (hoist) equipment's operating instructions.

GENERAL SUGGESTIONS

Know Your Crane

Crane operators should be familiar with the principal parts of a crane and have a thorough knowledge of crane control functions and movements. The crane operator should be required to know the location and proper operation of the main conductor disconnecting means for all power to the attachments on the crane.

Responsibility

Each crane operator should be held directly responsible for the safe operation of the crane. Whenever there is any doubt as to SAFETY, the crane operator should stop the crane and refuse to handle loads until: (1) safety has been assured or (2) the operator has been ordered to proceed by the supervisor, who then assumes all responsibility for the SAFETY of the lift.

Do not permit **ANYONE** to ride on the hook or a load.

Inspection

Test the crane movement and any attachments on the crane at the beginning of each shift. Whenever the operator finds anything wrong or apparently wrong, the problem should be reported immediately to the proper supervisor and appropriate corrective action taken.

Operating Suggestions

One measure of a good crane operator is the smoothness of the crane operation. The good crane operator should know and follow these proven suggestions for safe, efficient crane handling.

1. The crane should be moved smoothly and gradually to avoid abrupt, jerky movements of the load. Slack must be removed from the sling and hoisting ropes before the load is lifted.
2. Center the crane over the load before starting the hoist to avoid swinging the load as the lift is started. Loads should not be swung by the crane to reach areas not under the crane.
3. Crane-hoisting ropes should be kept vertical. Cranes shall not be used for side pulls.
4. Be sure everyone in the immediate area is clear of the load and aware that a load is being moved.
5. Do not make lifts beyond the rated load capacity of the crane, sling chains, rope slings, etc.
6. Make certain that before moving the load, load slings, load chains, or other lifting devices are fully seated in the saddle of the hook with hook latch closed (if equipped with hook latch).
7. Check to be sure that the load and/or bottom block is lifted high enough to clear all obstructions when moving boom or trolley.
8. At no time should a load be left suspended from the crane unless the operator has the push button with the power on, and under this condition keep the load as close as possible to the floor to minimize the possibility of an injury if the load should drop. When the crane is holding a load, the crane operator should remain at the push button.
9. Do not lift loads with sling hooks hanging loose. If all sling hooks are not needed, they should be properly stored, or use a different sling.
10. All slings or cables should be removed from the crane hooks when not in use (dangling cables or hooks hung in sling rings can inadvertently snag other objects when the crane is moving).
11. Operators shall not carry loads and/or empty bottom blocks over personnel. Particular additional caution should be practiced when using magnet or vacuum devices. Loads, or parts or loads, held magnetically could drop. Failure of power to magnets or vacuum devices can result in dropping the load. Extra precaution should be exercised when handling molten metal in the proximity of personnel.
12. Whenever the operator leaves the crane the following procedure should be followed:
 - Raise all hooks to an intermediate position.
 - Spot the crane at an approved designated location.
 - Place all controls in the "off" position.
 - Open the main switch to the "off" position.
 - Make visual check before leaving the crane.
13. In the case of emergency or during inspection, repairing, cleaning or lubrication, a warning sign or signal should be displayed and the main switch should be locked in the "off" position. This should be done whether the work is being done by the crane operator or by others.
14. Contact with rotation stops or trolley end stops shall be made with extreme caution. The operator should do so with particular care for the safety of persons below the crane, and only after making certain that any persons on the other cranes are aware of what is being done.
15. **ANY SAFETY FEATURES AND MECHANISMS BUILT-IN OR OTHERWISE PROVIDED WITH THE CRANE BY GORBEL ARE REQUIRED FOR THE SAFE OPERATION OF THE CRANE. DO NOT, UNDER ANY CIRCUMSTANCES, REMOVE OR OTHERWISE IMPAIR OR DISABLE THE PROPER FUNCTIONING OF ANY CRANE SAFETY MECHANISMS OR FEATURES BUILT-IN OR OTHERWISE PROVIDED BY GORBEL FOR SAFE OPERATION OF THE CRANE. ANY REMOVAL, IMPAIRMENT OR DISABLING OF ANY SUCH SAFETY MECHANISMS OR FEATURES OR OTHER USE OR OPERATION OF THE CRANE WITHOUT THE COMPLETE AND PROPER FUNCTIONING OF ANY SUCH SAFETY MECHANISMS OR FEATURES AUTOMATICALLY AND IMMEDIATELY VOIDS ANY AND ALL EXPRESS AND IMPLIED WARRANTIES OF ANY KIND OR NATURE.**

LIMITED WARRANTY

It is agreed that the equipment purchased hereunder is subject to the following LIMITED warranty and no other. Gorbel Incorporated ("Gorbel") warrants the manual push-pull Work Station Cranes, Jib Crane, and Gantry Crane products to be free from defects in material or workmanship for a period of ten years or 20,000 hours use from date of shipment. Gorbel warrants the Motorized Work Station Cranes and Jib Crane products to be free from defects in material or workmanship for a period of two years or 4,000 hours use from the date of shipment. Gorbel warrants the G-Force® and Easy Arm™ products to be free from defects in material or workmanship for a period of one year or 2,000 hours use from the date of shipment. This warranty does not cover Gantry Crane wheels. This warranty shall not cover failure or defective operation caused by operation in excess of recommended capacities, misuses, negligence or accident, and alteration or repair not authorized by Gorbel. No system shall be field modified after manufacture without the written authorization of Gorbel, Inc. Any field modification made to the system without the written authorization of Gorbel, Inc. shall void Gorbel's warranty obligation. OTHER THAN AS SET FORTH HEREIN, NO OTHER EXPRESS WARRANTIES, AND NO IMPLIED WARRANTIES, ORAL OR WRITTEN, INCLUDING BUT NOT LIMITED TO THE WARRANTIES OF MERCHANTABILITY OR FITNESS FOR PARTICULAR PURPOSE, ARE MADE BY GORBEL WITH RESPECT TO ITS PRODUCTS AND ALL SUCH WARRANTIES ARE HEREBY SPECIFICALLY DISCLAIMED. GORBEL SHALL NOT BE LIABLE UNDER ANY CIRCUMSTANCES FOR ANY INCIDENTAL, SPECIAL AND/OR CONSEQUENTIAL DAMAGES WHATSOEVER, WHETHER OR NOT FORESEEABLE, INCLUDING BUT NOT LIMITED TO DAMAGES FOR LOST PROFITS AND ALL SUCH INCIDENTAL, SPECIAL AND/OR CONSEQUENTIAL DAMAGES ARE HEREBY ALSO SPECIFICALLY DISCLAIMED. Gorbel's obligation and Purchaser's or end user's sole remedy under this warranty is limited to the replacement or repair of Gorbel's products at the factory, or at the discretion of Gorbel, at a location designated by Gorbel. Purchaser or end user shall be solely responsible for all freight and transportation costs incurred in connection with any warranty work provided by Gorbel hereunder. Gorbel will not be liable for any loss, injury or damage to persons or property, nor for damages of any kind resulting from failure or defective operation of any materials or equipment furnished hereunder. Components and accessories not manufactured by Gorbel are not included in this warranty. Purchaser's or end user's remedy for components and accessories not manufactured by Gorbel is limited to and determined by the terms and conditions of the warranty provided by the respective manufacturers of such components and accessories.

A) DISCLAIMER OF IMPLIED WARRANTY OF MERCHANTABILITY

Gorbel and Purchaser agree that any claim made by Purchaser which is inconsistent with Gorbel's obligations and the warranty remedies provided with Gorbel's products, and in particular, special, incidental and consequential damages, are expressly excluded.

B) DISCLAIMER OF IMPLIED WARRANTY OF FITNESS FOR PARTICULAR PURPOSE

Gorbel and Purchaser agree that the implied warranty of fitness for particular purpose is excluded from this transaction and shall not apply to the goods involved in this transaction.

C) DISCLAIMER OF EXPRESS WARRANTY

Gorbel's agents, or dealer's agents, or distributor's agents may have made oral statements about the machinery and equipment described in this transaction. Such statements do not constitute warranties, and Purchaser agrees not to rely on such statements. Purchaser also agrees that such statements are not part of this transaction.

D) DISCLAIMER OF SPECIAL, INCIDENTAL AND CONSEQUENTIAL DAMAGES

Gorbel and Purchaser agree that any claim made by Purchaser which is inconsistent with Gorbel's obligations and the warranty remedies provided with Gorbel's products, and in particular, special, incidental and consequential damages, are expressly excluded.

E) DEALER OR DISTRIBUTOR NOT AN AGENT

Gorbel and Purchaser agree that Purchaser has been put on notice that dealer or distributor is not Gorbel's agent in any respect for any reason. Gorbel and Purchaser also agree that Purchaser has been put on notice that dealer or distributor is not authorized to incur any obligations or to make any representations or warranties on Gorbel's behalf other than those specifically set forth in Gorbel's warranty provided in connection with its product.

F) MERGER

This warranty agreement constitutes a final and complete written expression of all the terms and conditions of this warranty and is a complete and exclusive statement of those terms.

G) PAINTING

Every crane (excluding components) receives a quality paint job before leaving the factory. Unfortunately, no paint will protect against the abuses received during the transportation process via common carrier. We have included at least one (1) twelve ounce spray can for touchup with each crane ordered (unless special paint was specified). If additional paint is required, contact a Gorbel® Customer Service Representative at 1-800-821-0086 or 1-585-924-6262.

Title and Ownership:

Title to the machinery and equipment described in the foregoing proposal shall remain with Gorbel and shall not pass to the Purchaser until the full amount herein agreed to be paid has been fully paid in cash.

Claims and Damages:

Unless expressly stated in writing, goods and equipment shall be at Purchaser's risk on and after Seller's delivery in good shipping order to the Carrier. Gorbel shall in no event be held responsible for materials furnished or work performed by any person other than it or its authorized representative or agent.

Cancellations:

If it becomes necessary for the purchaser to cancel this order wholly or in part, he shall at once so advise Gorbel in writing. Upon receipt of such written notice all work will stop immediately. If the order entails only stock items, a flat restocking charge of 15% of the purchase price will become due and payable by Purchaser to Gorbel. Items purchased specifically for the canceled order shall be charged for in accordance with the cancellation charges of our supplier plus 15% for handling in our factory. The cost of material and/or labor expended in general fabrication for the order shall be charged for on the basis of total costs to Gorbel up to the time of cancellation plus 15%.

Returns:

No equipment, materials or parts may be returned to Gorbel without express permission in writing to do so.

Extra Charge Delay: If Purchaser delays or interrupts progress of Seller's performance, or causes changes to be made, Purchaser agrees to reimburse Gorbel for expense, if any, incident to such delay.

Changes and Alterations:

Gorbel reserves the right to make changes in the details of construction of the equipment, as in its judgment, will be in the interest of the Purchaser; will make any changes in or additions to the equipment which may be agreed upon in writing by the Purchaser; and Gorbel is not obligated to make such changes in products previously sold any customer.

Third Party Action:

Should Gorbel have to resort to third party action to collect any amount due after thirty (30) days from date of invoice, the Purchaser agrees to pay collection costs, reasonable attorney's fees, court costs and legal interest.

OSHA Responsibilities:

Gorbel agrees to fully cooperate with Purchaser in the design, manufacture or procurement of safety features or devices that comply with OSHA regulations. In the event additional equipment or labor shall be furnished by Gorbel, it will be at prices and standard rates then in effect, or as may be mutually agreed upon at the time of the additional installation.

Equal Employment Opportunity:

Gorbel agrees to take affirmative action to ensure equal employment opportunity for all job applicants and employees without regard to race, color, age, religion, sex, national origin, handicap, veteran, or marital status. Gorbel agrees to maintain non-segregated work facilities and comply with rules and regulations of the Secretary of Labor or as otherwise provided by law or Executive Order.

INSPECTION AND MAINTENANCE SCHEDULE

GORBEL® TRACTOR DRIVE: INSPECTION AND MAINTENANCE SCHEDULE			
ITEM	COMPONENT	MAINTENANCE	FREQUENCY*
1	Drive Wheel	Check wheel tread for uneven wear, tread separation, and/or damage. If any of these conditions exist, wheels may need to be replaced. Uneven wear may be corrected with counterweight, reducer mounting, and/or track alignment.	Every 2,000 hours or yearly
2	Counter Weight Hardware	Check that all hardware is tightened to the torque specifications noted on page 7.	Every 2,000 hours or yearly
3	Adjustment Trolley Hardware	Spring compression should be adjusted to prevent drive wheel slip-page. Check that hex nut and jam nut are tightened snug.	Every 2,000 hours or yearly
4	Drive Wheel Hardware	Check that socket head cap screw is tightened to the torque specifications noted on page 7.	Every 2,000 hours or yearly
5	Reducer Mounting Hardware	Check that all hardware is tightened to the torque specifications noted on page 7.	Every 2,000 hours or yearly
6	Trolley Mounting Hardware	Check that all nuts are tightened snug. These bolts are furnished with nylock nuts and should not be overtightened. If nylock nuts are removed they must be replaced.	Every 2,000 hours or yearly
7	Trolley Wheels	Check for cracks, pits, and/or grooves: all of these increase pull forces. If any of these conditions exist, wheels should be replaced.	Every 2,000 hours or yearly

* Federal, state and local codes may require inspection and maintenance checks ore often. Please check the federal, state and local code manuals in your area.

Note: Gear box is sealed with a high grade synthetic lubricant. Replacement is not required.

WARNING

Any changes in operation or unusual noises must be immediately identified and corrected.

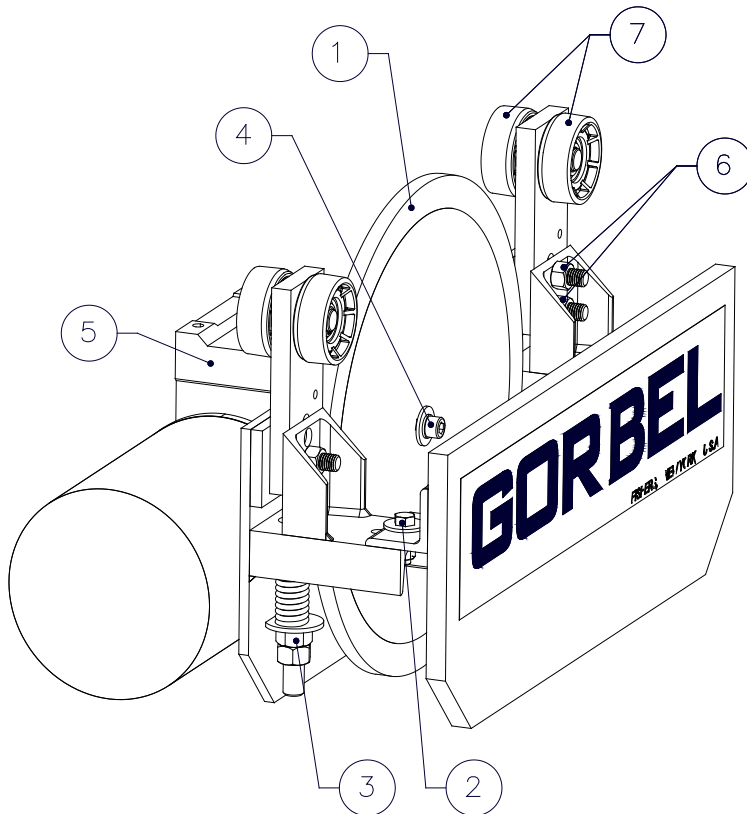

GORBEL®
A CLASS ABOVE

600 Fishers Run, P.O. Box 593
Fishers, NY 14453-0593
Telephone: (800) 821-0086
Fax: (800) 828-1808
E-mail: info@gorbel.com
<http://www.gorbel.com>

© 2011 Gorbelt, Inc.
All Rights Reserved

 linkedin.com/company/gorbel

 Facebook
[Facebook.com/gorbelinc](https://facebook.com/gorbelinc)

 youtube.com/gorbelmarketing

 Twitter
twitter.com/gorbelinc

 gorbel.com/blog