

Ceiling Mounted Aluminum Work Station Bridge Crane and Monorail

Installation, Operation & Maintenance Manual

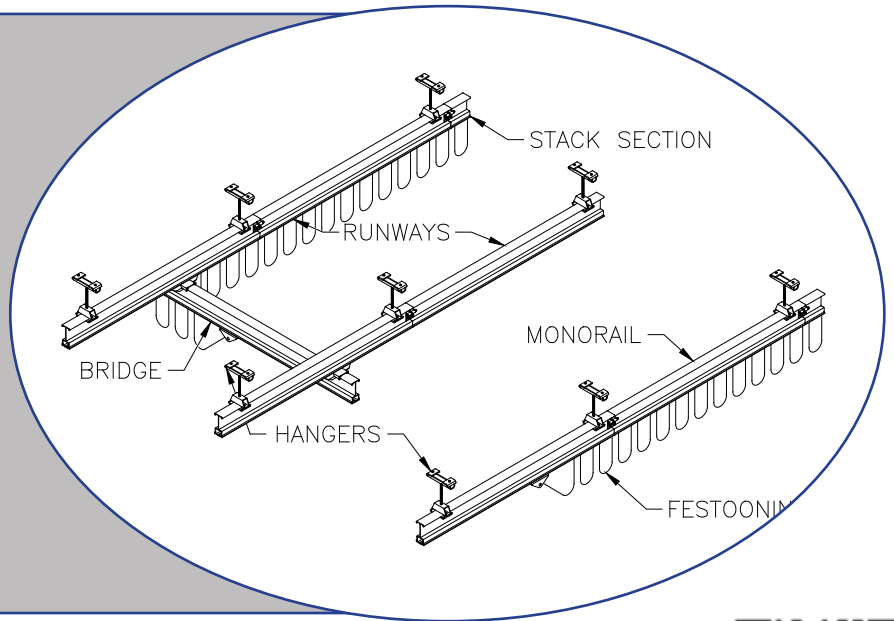

Part Number: MAN-US071-R02 Released 3/2026
Find manual updates at:
<https://www.gorbel.com/service-support/archived-installation-manuals>



Scan to Register
Your Warranty

Gorbel[®] Customer Order No. / Serial No.

Gorbel[®] Dealer

Table of Contents

Introduction	1
Installation.....	2
Step 1 - Pre-Assembly	2
Step 2 - Standard Hanger Installation	2
Step 2 - Automotive Hanger Installation (Optional)	4
Step 3 - Standard Runway Installation	5
Step 3 - Runway Installation (Continued)	6
Step 4 - Splice Joint Installation	7
Step 5 - Bridge and End Truck Installation	8
Step 6 - Hoist Trolley Installation	17
Step 7 - Festoon Stack Installation	20
Step 8 - Festooning Installation	21
Step 9 - Bridge and Runway Tagline Installation	25
Step 10 - Optional Accessories	26
Step 10 - Optional Accessories	27
Step 11 - Final Steps	28
Step 12 - Sway and Thrust Bracing Guidelines	30
Crane Operator Instructions	32
General Suggestions	33
Limited Warranty	35
Inspection and Maintenance Schedule	38

*Federal, state and local codes may require inspection and maintenance checks more often. Please check the federal, state and local codes in your area. 38

Introduction

Thank you for choosing Gorbel® Aluminum Work Station Cranes to solve your material handling needs. The innovative design and heavy duty construction of the Gorbel® Work Station Cranes will provide a superior quality product that will offer years of long term value. All Gorbel® cranes are pre-engineered for powered hoist operation. The hoist weight allowance is 15% of the crane's capacity (for example, a crane rated for 1000 pounds, allows for a 1000-pound live load plus 150 pounds for the weight of the hoist). Gorbel® Work Station Cranes will provide many years of dependable service by following the installation and maintenance procedures described herein.

Dimensions contained in this installation manual are for reference only and may differ for your particular application. Please refer to the enclosed General Arrangement Drawing for actual dimensions.

Normal safety precautions - these include, but are not limited to:

- Checking for obstructions in crane travel
- Checking that all bolts and threaded rods are tight and have lockwashers
- Making sure that end stops are in place
- Making sure that festooning cannot be snagged or pinched, whether it is electric or pneumatic

For additional safety precautions, see page 31.



WARNING: Only competent erection personnel familiar with standard fabrication practices should be employed to assemble these cranes because of the necessity of properly interpreting these instructions. Gorbel is not responsible for the quality of workmanship employed in the installation of a crane according to these instructions. Contact Gorbel, Inc., at 600 Fishers Run, P.O. Box 593, Fishers, New York 14453-0593, 1-800-821-0086, for any additional information if necessary.



WARNING: Equipment described herein is not designed for, and should not be used for, lifting, supporting or transporting humans. Failure to comply with any one of the limitations noted herein can result in serious bodily injury and/or property damage. Check State and Local regulations for any additional requirements.



WARNING: Crane cannot be utilized as a ground: A separate ground wire is required. For example, systems with 3-phase power require three conductors plus one ground wire.



WARNING: Before installing any crane system, it is critical you determine that your building will safely support the loads. Gorbel® Inc. assumes no responsibility for adequacy or integrity of the mounting surface.



WARNING: Sway bracing is required (except when using flush mounted hangers). For more information see page 29.



WARNING: Reference the American Institute of Steel Construction (AISC) Manual of Steel Construction (9th edition), Part 5, Specification for Structural Joints using ASTM A325 or A490 Bolts (section 8.d.2) for the proper procedures to follow when using any torque-tightening method.



WARNING: Unless otherwise specifically stated, Gorbel® parts and products are designed for indoor use. Storing and/or using your items outside (even if covered), exposed to the elements, or in any method other than intended, may void all or some of the product warranty. Always store Gorbel® parts and products indoors, in a cool and dry area.

Installation

Step 1 - Pre-Assembly

TIP: Packing list can be found in plastic pocket inside hardware box. General Arrangement Drawing and additional inserts can be found enclosed in this installation manual.

- 1.1 Read entire installation manual **before** you begin installation your crane.
- 1.2 Check packing list to make sure **correct quantity** of parts is included.
- 1.3 Tools and materials (by others) typically needed to assemble crane are as follows:
 - Hand tools
 - Leveling tools
 - Ladders/man lifts
 - Torque wrench (able to torque up to 200 ft.-lb.)
 - Steel shims (for flush mounted hangers)
 - Powered metal-cutting saw

Step 2 - Standard Hanger Installation

NOTE: Standard top hanger brackets are designed for flange widths from 1-10 inches.

Top Hanger Assemblies

- 2.1 Mark top hanger placement on the building support beams and runway/monorail track (refer to **General Arrangement Drawing**, inserted in this manual, for hanger placement).

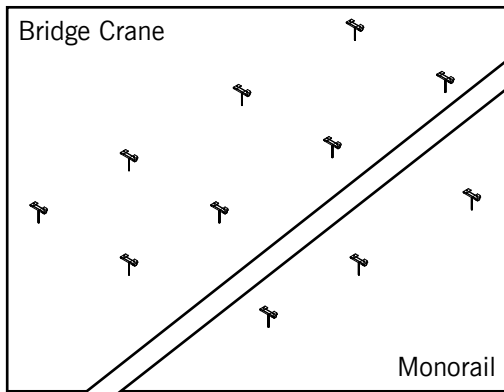

- 2.2 To attach threaded rod to top hanger bracket: Assemble top hanger components (**diagram 2A**). Refer to Torque Chart (**chart 2A**) for proper hardware torque.

TORQUE CHART	
*Bolt Diameter	Torque
1/2"	50 ft.-lb.
5/8"	95 ft.-lb.
3/4"	170 ft.-lb.

Chart 2A. Torque chart.
*Note: All bolts shall be SAE Grade 5 or equal.

WARNING: Threaded rod must have a minimum of two threads showing beyond the hexnut.

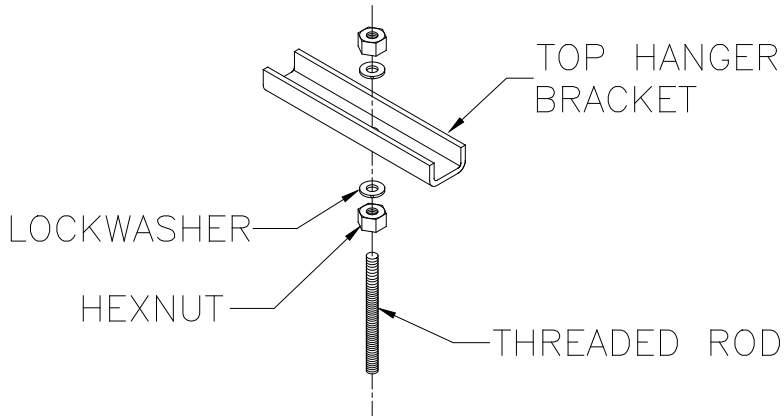

Diagram 2A.
Attaching threaded rod to top hanger bracket.

2.3 Bolt top hanger assembly and beam clips to building support beam (**diagram 2B**).

Lower Hanger Assemblies

2.4 Attach track clips to lower hanger assembly and tighten, as shown in **diagram 2C**. Refer to **chart 2A** for proper hardware torque.

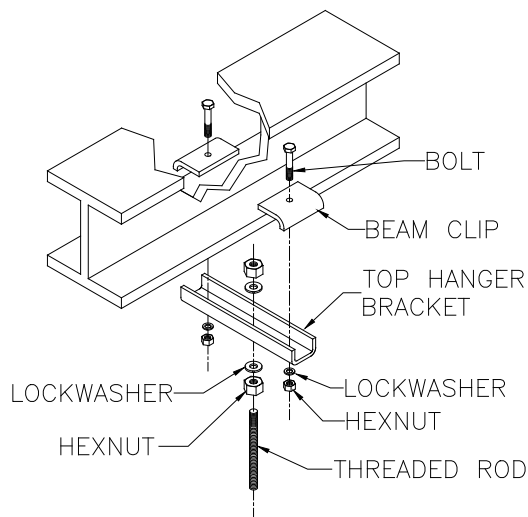

Diagram 2B.
Bolting top hanger bracket and beam clips to existing support beam.

WARNING: "Center hole" of the top hanger bracket assembly must be centered to building support beam.

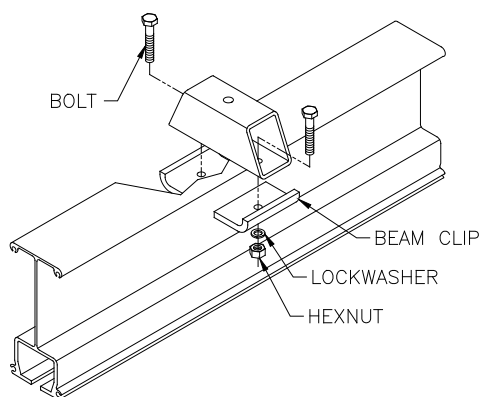

Diagram 2C.
Attaching lower hanger to track section.

Step 2 - Automotive Hanger Installation (Optional)

Top Hanger Assemblies

- 2.5 Mark top hanger placement on the building support beams and runway/monorail track (refer to **General Arrangement Drawing**, inserted in this manual, for hanger placement). If no drawing was provided then note: **MAXIMUM** distance between hangers is 20'-0".
- 2.6 Attached "T" hanger to the top of the track (**diagram 2D**). Refer to **chart 2A, on page 2**, for proper hardware torque.

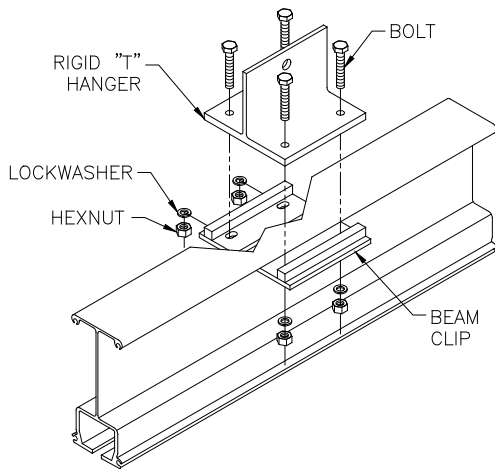

Diagram 2D. Clamp "T" hanger to top of Aluminum track with 4 bolts and 2 beam clips.

WARNING: Bolts must have a minimum of two threads showing beyond the hexnut.

WARNING: Threaded rod must have a minimum of two threads showing beyond the hexnut.

WARNING: Threaded rod must be allowed to hang "plumb" and should not be bent to accommodate sloped ceilings.

IMPORTANT: The closer the runways/monorail are to level and parallel, the better the crane will perform.

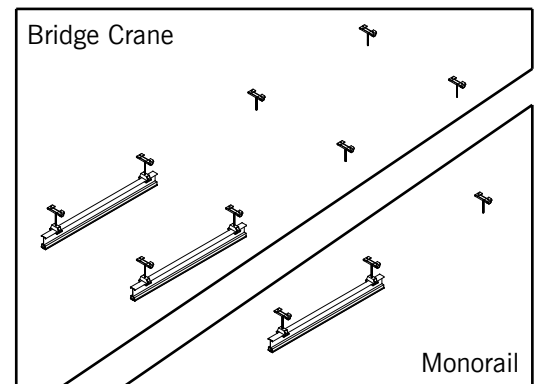

Step 3 - Standard Runway Installation

3.1 Lift the runway/monorail into place for installation.

3.2 Hangers

For hangers with threaded rod drop

Insert threaded rod into bolt hole on the lower hanger assembly and bolt into place (**diagram 3A**).

Tighten hexnuts to the recommended ratings listed in **chart 2A, on page 2**.

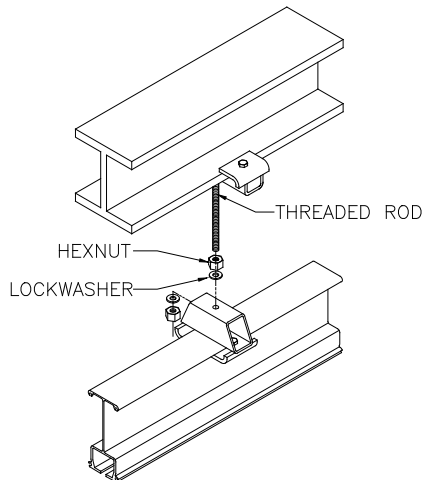

Diagram 3A. Installing runways to hanger assembly with threaded rod drop.

For Automotive plant installations

Bolt "T" hanger to the support steel provided (by others) using the two holes in the vertical section of the "T" (**diagram 3B**).

Tighten hex nuts to the recommended ratings listed in **chart 2A, on page 2**.

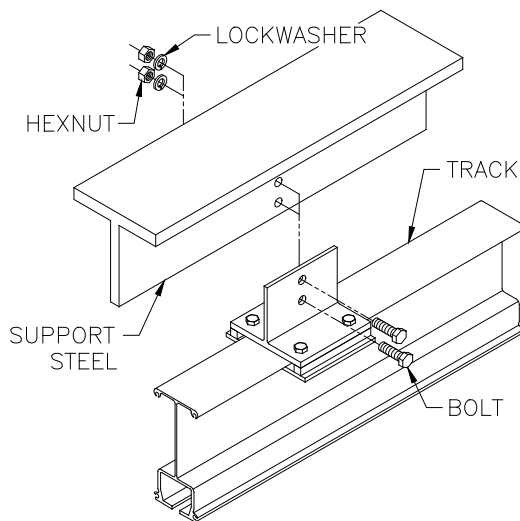

Diagram 3B. Installing runways to "T" style automotive support assembly.

3.3 Level Track:

Check to make sure that the lower flange of track is level (within $\pm 1/8"$) and parallel to opposite runway (within $\pm 1/8"$) over a 20'-0" distance.

Step 3 - Runway Installation (Continued)

IMPORTANT: The closer the runways/monorail are to level and parallel, the better the crane will perform.

3.4 If you **do** have additional runways/monorail sections, proceed to **Step 4 on page 7**.

If you **do not** have additional runway sections:

Standard Endstop installation

Install endstops (**diagram 3C**) (molded bumper with thru bolt), to runway end opposite festooning end. For more information on festooning, refer to **Steps 7 and 8**.

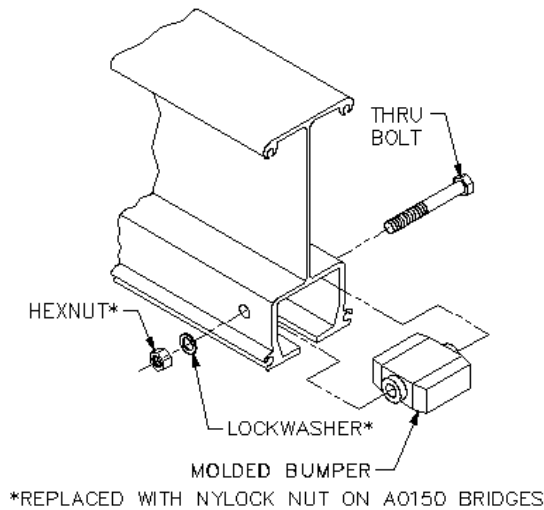

Diagram 3C. Installing standard endstop.

Tighten nut on thru bolt until lockwasher is flat.

If you have a bridge crane, go to **Step 5**.

If you have a monorail, go to **Step 6**.

Automotive Endstop installation

Install endstops (**diagram 3D**) (molded bumper with thru bolt), to runway end opposite festooning end. **For more information on festooning, refer to Steps 7 and 8 on page 21.**

Tighten nut on thru bolt until lockwasher is flat.

WARNING: Do not over-tighten nylock nut; this could cause damage to bridge. Nylock nut can only be used once. If this item is disassembled then nut must be replaced.

If you have a bridge crane, go to **Step 5 on page 9**.

If you have a monorail, go to **Step 6 on page 17**.

Automotive Endstop installation

Install endstops (**diagram 3D**) (molded bumper with thru bolt), to runway end opposite festooning end. For more information on festooning, refer to **Steps 7 and 8**.

Tighten nut on thru bolt until lockwasher is flat.

If you have a bridge crane, go to **Step 5 on page 8**.

If you have a monorail, go to **Step 6 on page 17**.

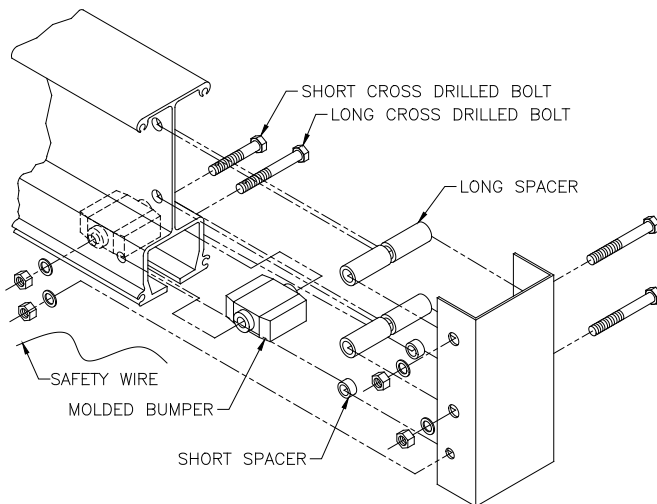
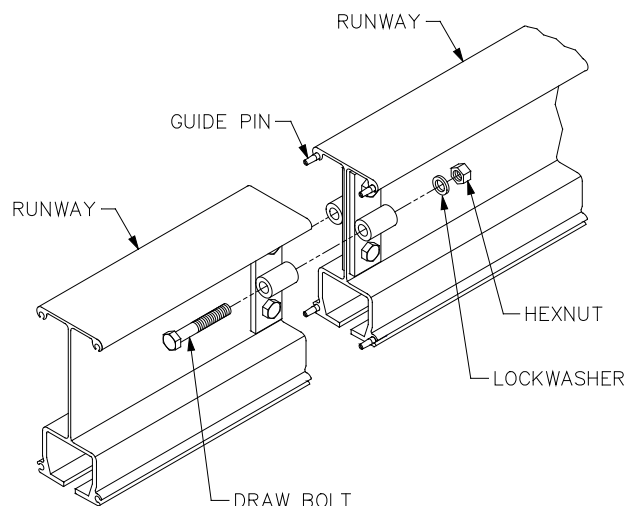
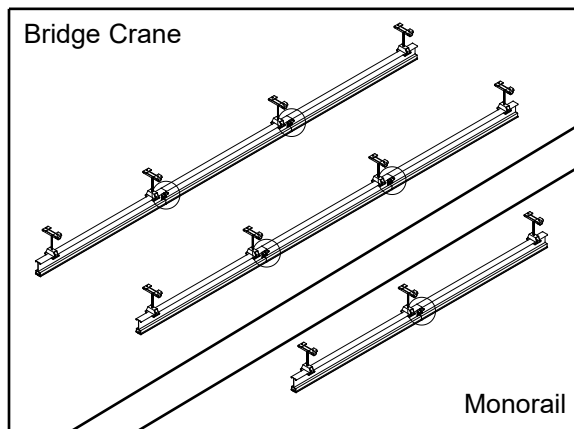

Diagram 3D. Installing the automotive style double wired endstop with endcap.

Step 4 - Splice Joint Installation

IMPORTANT: Be sure guide pins are in place before joining track sections together.

WARNING: Do not deviate from the dimensions specified in the **General Arrangement Drawing**. If a drawing was not provided, then note, **MAXIMUM** distance from splice to hanger is **30 inches**.



Step 4 - Splice Joint Installation (Continued)

- 4.1 Attach splice brackets to all track joints (2 per track end to be spliced) (diagram 4A). Maximum gap between ends of load carrying flange shall be less than or equal to 1/16" (1.55mm).

Tighten hexnuts to the recommended ratings listed in chart 2A, on page 2.

- 4.2 Install "guide pins" (total of 4 per splice) (diagram 4A). The guide pins should be screwed into the track section so that no thread is showing.

Do not screw the pins in too far. For ease of final splice assembly, be sure guide pins are installed straight.

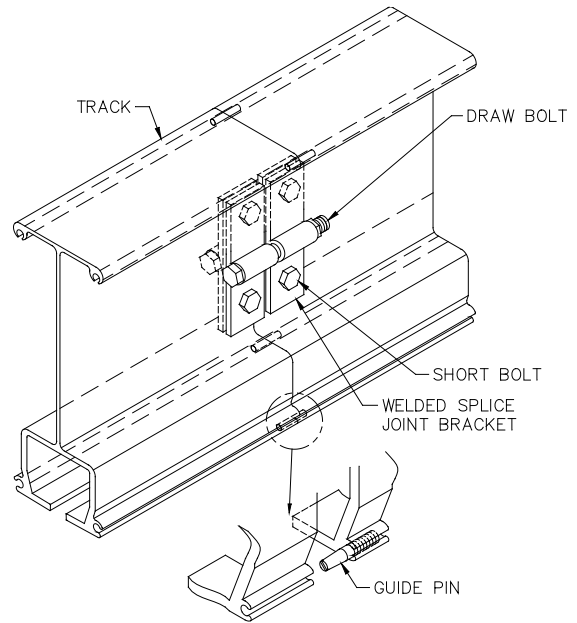

Diagram 4A. Splicing Aluminum track sections.

NOTE: For Automotive Installation guide pins are pre-installed by Gorbels® .

- 4.3 Lift the runway section into place, line up the guide pins, and use the "draw" bolts to bring the two sections of track together.

Tighten hardware until lockwashers are fully compressed, and there is no gap between the track sections.

- 4.4 For additional runways repeat **Steps 4.1 through 4.3**.
- 4.5 Install endstops (refer to **Step 3.4, on page 6**).

Step 5 - Bridge and End Truck Installation

IMPORTANT: Only one end truck is clamped to the bridge: the other is not. The clamping end truck must be oriented with the festooning side of the track (refer to **Step 8** for festooning). The non-clamping end truck allows adjustment for any runway misalignment.

IMPORTANT: Make sure nylon spacers are attached to end truck before installing end truck on bridge.

IMPORTANT: Your end truck may vary slightly from what is shown, but the installation instructions for the end truck most resembling what you have remain the same.

Step 5 - Bridge and End Truck Installation (Continued)

- 5.1 Make sure endstops have been installed in the runway end opposite the festooning (leaving the festooning end open for bridge installation).
- 5.2 Prior to adding the bridge, clean the inside flanges of track with a clean dry cloth (do not use any kind of cleaning solutions) to remove grit or debris that may have collected during shipping, storage or installation.
- 5.3 If your end truck looks like:

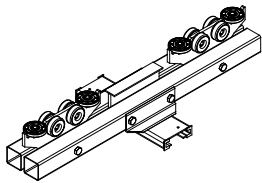

(Shipped Unassembled)
go to Step 5.29

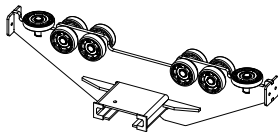

(Shipped Assembled)
go to Step 5.4

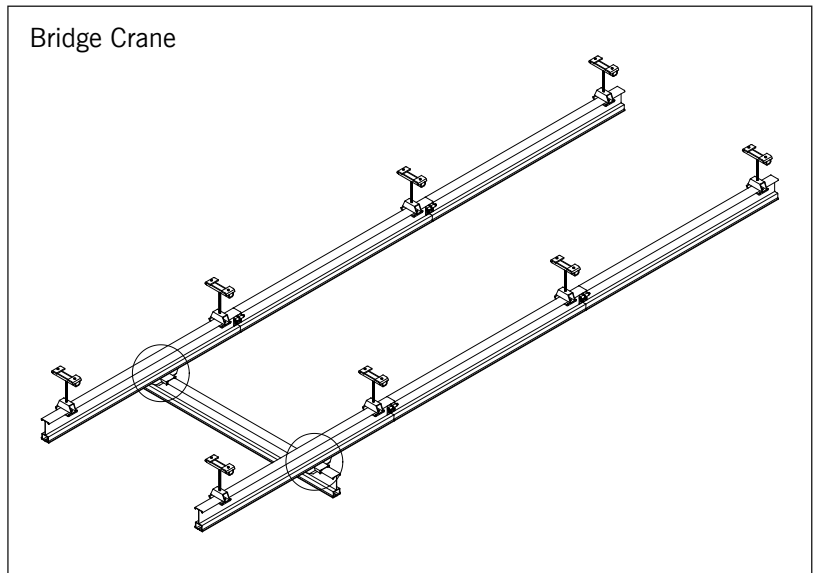

Standard End Truck Assembly

- 5.4 Slide an end truck over the festooning end of the bridge (refer to the **General Arrangement Drawing** for exact end truck location) and clamp into place (**diagram 5A**).

NOTE: The festooning end of the bridge will have a hole that is inset the same or greater distance from the end of the bridge than the hole in the opposite end of the bridge.

- 5.5 Slide and position the non-clamping end truck on the other end of the bridge.
- 5.6 At both ends of the bridge, install a shear lug bolt in hole at top of bridge (or in the coped brackets) to prevent bridge from sliding out of end trucks (**diagram 5A**).

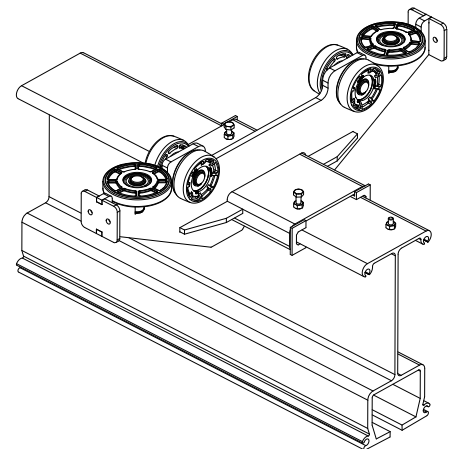

Diagram 5A. Installing standard clamping end truck on an Aluminum Bridge.

Step 5 - Bridge and End Truck Installation (Continued)

NOTE: Install bolts with head of bolt on underside of top flange with threads pointing up.

5.7 Go to Step 5.27.

IMPORTANT: Only one end truck is clamped to the bridge: the other is not. The clamping end truck must be oriented with the festooning side of the track (refer to Steps 8 for festooning). The non-clamping end truck allows adjustment for any runway misalignment.

IMPORTANT: Make sure nylon spacers are attached to end truck before installing end truck on bridge.

Coped/Two-Piece Aluminum Bridge Assembly

5.8 Bolt coped/two-piece bridge brackets to coped/two-piece aluminum bridge on both sides, at both ends (**diagram 5B**). Torque nuts to 30 ft.-lbs.

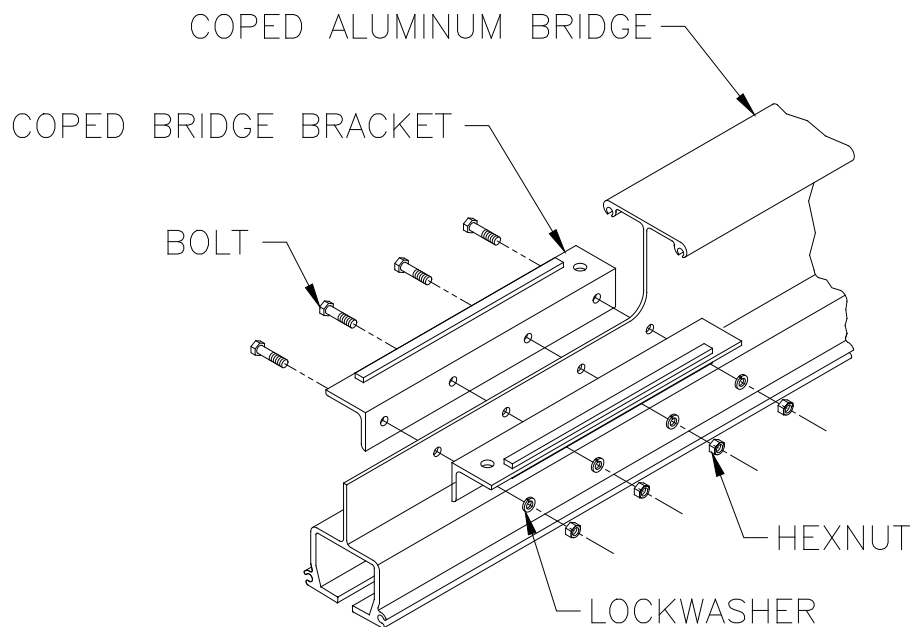

Diagram 5B. Installing brackets on coped/two-piece aluminum bridge.

Step 5 - Bridge and End Truck Installation (Continued)

- 5.9 Slide an end truck over coped brackets on the festooning end of bridge (refer to the General Arrangement Drawing for exact end truck location) and clamp into place (**diagram 5C**).

NOTE: The festooning end of the bridge will have an end stop hole that is inset the same or greater distance from the end of the bridge than the end stop hole in the opposite end of the bridge.

- 5.10 Slide and position the non-clamping end truck on the other end of the bridge.
- 5.11 At both ends of the bridge, install a shear lug bolt in the hole closest to the end of the bridge in the top of the coped/two-piece bridge brackets (**diagram 5C**).

NOTE: Install bolts with head of bolt on underside of top flange with threads pointing up.

- 5.12 Go to Step 5.27.

WARNING: Failure to install shear lug bolt assemblies may result in the bridge, hoist, and load falling to the floor.

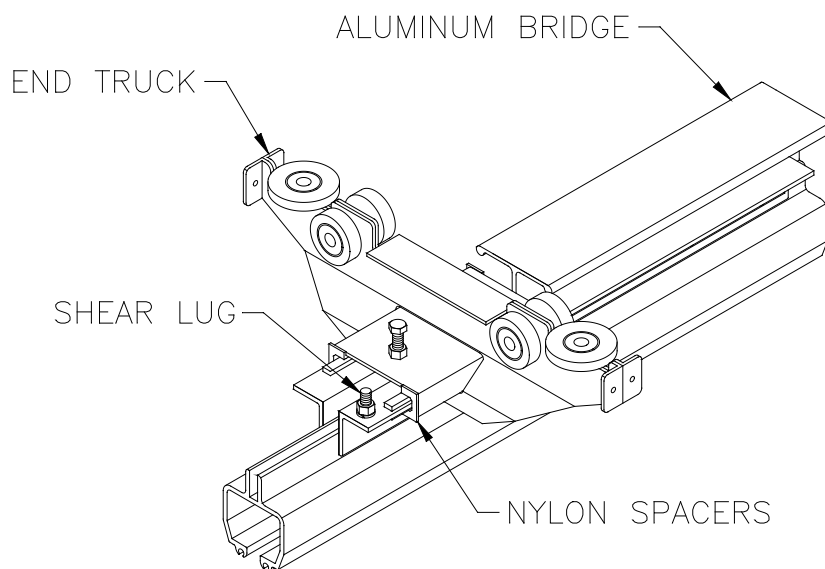

Diagram 5C. Installing clamping end truck on coped/two-piece aluminum bridge.

Step 5 - Bridge and End Truck Installation (Continued)

IMPORTANT: Only one end truck is clamped to the bridge: the other is not. The clamping end truck must be oriented with the festooning side of the track (refer to **Steps 8, on page 21** for festooning). The non-clamping end truck allows adjustment for any runway misalignment.

IMPORTANT: Make sure nylon spacers are attached to end truck before installing end truck on bridge.

Automotive Style End Truck Assembly

- 5.13 Slide an end truck over the festooning end of the bridge (refer to **General Arrangement Drawing** for exact end truck location) and clamp into place (**diagram 5D**).

NOTE: The festooning end of the bridge will have a hole that is inset the same or greater distance from the end of the bridge than the hole in the opposite end of the bridge.

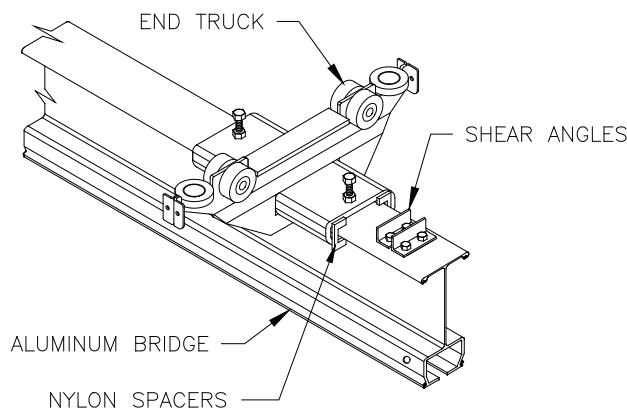

Diagram 5D. Installing automotive style clamping end truck on an Aluminum Bridge.

- 5.14 Slide and position the non-clamping end truck on the other end of the bridge.
- 5.15 At both ends of the bridge, install shear angles in the holes at the top of the bridge to prevent bridge from sliding out of end trucks (**diagram 5D**).

WARNING: Failure to install shear angle assemblies may result in the bridge, hoist, and load falling to the floor.

NOTE: Each end of the bridge requires two shear angles. Tighten the hexnuts on each angle set to the recommended ratings listed in chart **2A, on page 2**. Shear angle bolts should be safety wired together on both sides of track T-section.

- 5.16 Go to **Step 5.27, on page 16**.

Step 5 - Bridge and End Truck Installation (Continued)

IMPORTANT: Only one end truck is clamped to the bridge: the other is not. The clamping end truck must be oriented with the festooning side of the track (refer to **Step 8, on page 21** for festooning). The non-clamping end truck allows adjustment for any runway misalignment.

IMPORTANT: Extended end truck should be assembled before attaching to bridge.

IMPORTANT: Make sure nylon spacers are attached to end truck before installing end truck on bridge.

Extended End Truck Assembly

- 5.17 Locate extended end truck tubes, support weldment, wheel plates, and required hardware.
- 5.18 Slide an extended end truck tube halfway through each side of the end truck support weldment. Insert a support bolt in each hole of the support weldment, passing through both end truck tubes (**diagram 5E**).

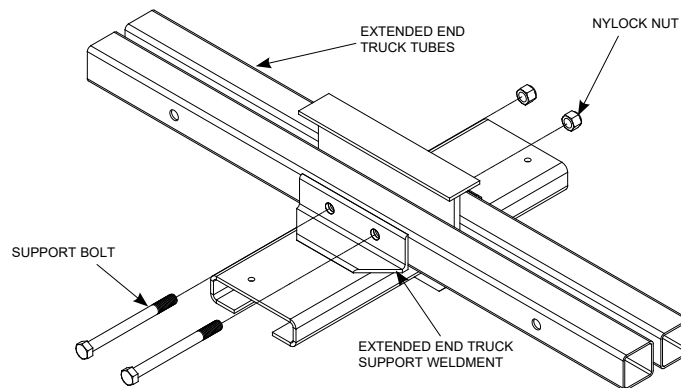

Diagram 5E. Assembling extended end truck.

- 5.19 Place nylock nut on each bolt and tighten snug against end truck support weldment.

WARNING: Do not **over-tighten** nylock nut: this could cause damage to end trucks. Nylock nut can only be used once. If this item is disassembled, then nut must be replaced.

Step 5 - Bridge and End Truck Installation (Continued)

Extended End Truck Assembly (Continued)

- 5.20 Place a wheel plate between the end truck tubes. Insert 5/8" dia. bolt into first tube, through the heel plate and out the opposite tube (**diagram 5F**).

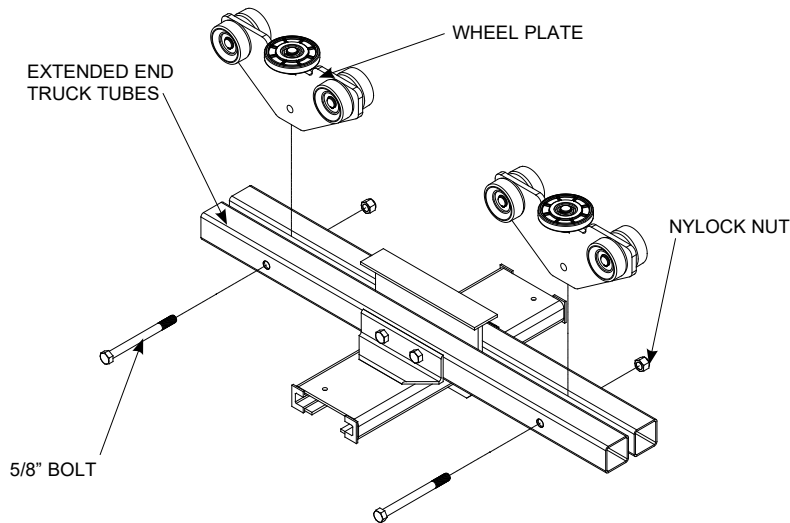

Diagram 5F. Installing wheel plates.

- 5.21 Place nylock nut on end of bolt and tighten snug against extended end truck tube.

WARNING: Do not **over-tighten** nylock nut: this could cause damage to end trucks. Nylock nut can only be used once. If this item is disassembled, then nut must be replaced.

NOTE: When tightening this lock nut make sure that wheel plate pivots freely.

- 5.22 Repeat steps **5.20** and **5.21** for remaining wheel plate.
- 5.23 Repeat steps **5.17** to **5.22** for remaining extended end trucks.

Step 5 - Bridge and End Truck Installation (Continued)

IMPORTANT: Only one end truck is clamped to the bridge: the other is not. The clamping end truck must be oriented with the festooning side of the track (refer to **Steps 8, on page 13** for festooning). The non-clamping end truck allows adjustment for any runway misalignment.

Extended End Trucks (continued)

- 5.24 Slide an end truck over festooning end of bridge (refer to **General Arrangement Drawing** for exact end truck location) and clamp into place (**diagram 5G**).

NOTE: The festooning end of the bridge will have a hole that is inset the same or greater distance from the end of the bridge than the hole in the opposite end of the bridge.

- 5.25 Slide and position the non-clamping end truck on the other end of bridge (refer to the **General Arrangement Drawing** for exact location).
- 5.26 At both ends of bridge, install a shear lug bolt in the hole in the coped brackets to prevent bridge from sliding out of end trucks (**diagram 5G**).

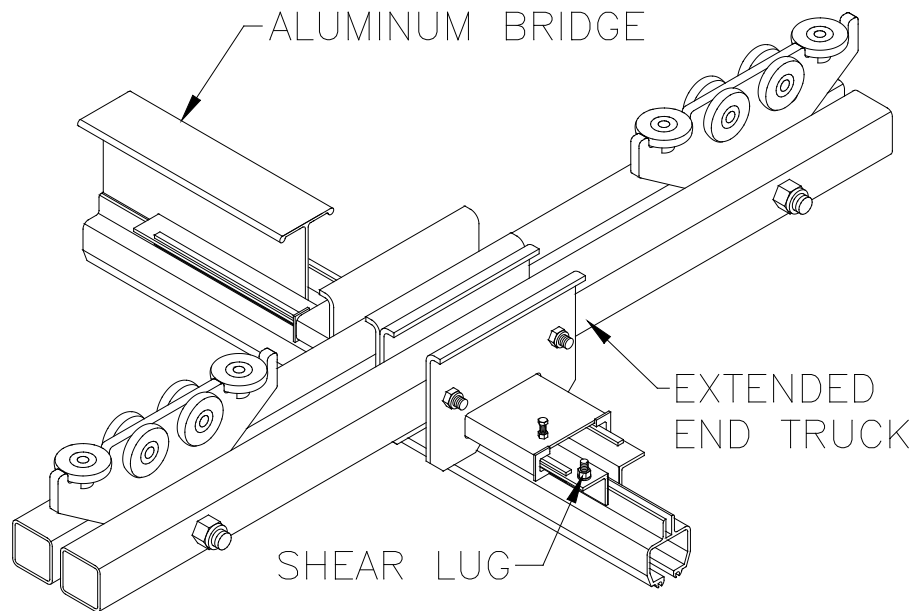

Diagram 5G. Installing extended clamping end truck.

NOTE: Install bolts with head of bolt on underside of top flange with threads pointing up.

WARNING: Failure to install shear lug bolt assemblies may result in the bridge, hoist, and load falling to the floor.

Step 5 - Bridge and End Truck Installation (Continued)

Extended End Truck Assembly (Continued)

- 5.27 Install an end stop to the end of the bridge opposite the festooning (**diagrams 5H or 5I**).
- 5.28 Lift bridge up to runways and simultaneously insert end trucks into open ends of runways. Make sure festooning end of bridge is oriented with festooning runway. For information on festooning, refer to **Step 8, on page 21**.
- 5.29 Immediately install end stops in open ends of runways to prevent bridge from exiting runways (**diagrams 5H or 5I**).
- 5.30 Roll bridge down length of runways to check for smooth travel. If travel is not smooth, check track for level and parallel (**Step 3.3, page 5**) and check to make sure that only one end truck on bridge is clamped.

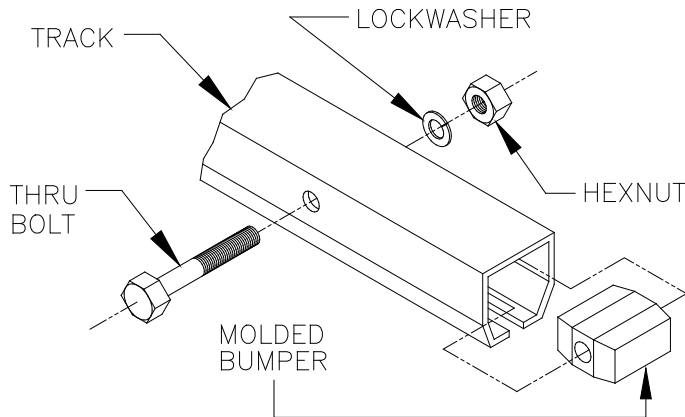

Diagram 5H. Installing end stop.

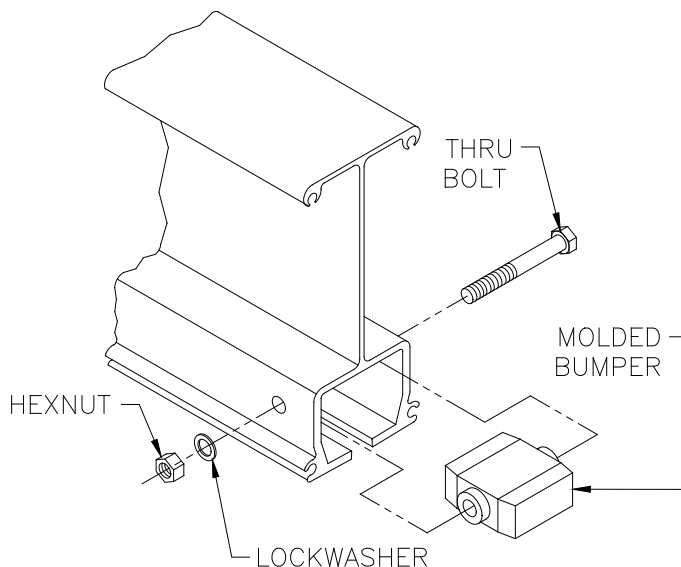
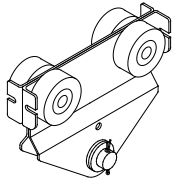

Diagram 5I. Installing end stop.

Step 6 - Hoist Trolley Installation

Trolleys for Standard Applications

6.1 Your trolley should look like this:



A150-A1000 series

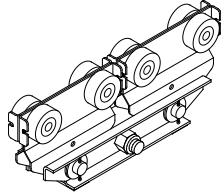

A2000 series (Shipped Assembled)

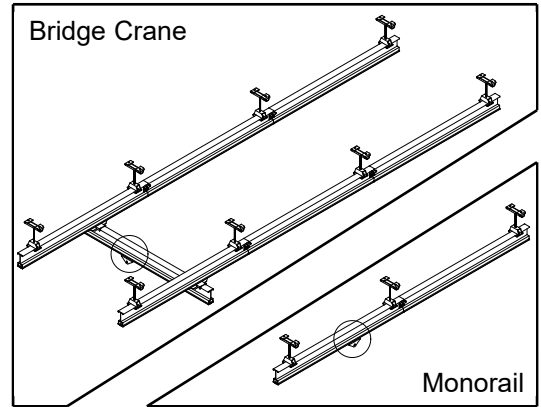

- 6.2 Clean inside flanges of track with a clean, dry cloth (do not use any kind of cleaning solution) to remove grit or debris that may have collected during shipping, storage, or installation.
- 6.3 Be sure endstop is installed opposite the festooning end of the bridge/monorail.
- 6.4 Attach hoist to hoist trolley by snapping the hoist suspension hook over the clevis pin of the hoist trolley.
- 6.5 If hoist suspension hook is too large or hoist has a suspension device other than a hook, you will need to remove the trolley clevis pin to install the suspension device (by others). Insert clevis pin back into place. Slide washers on clevis pin and insert cotter pin through trolley saddle clevis pin diagrams **6A**, **6B**, **6C** or **6D**.

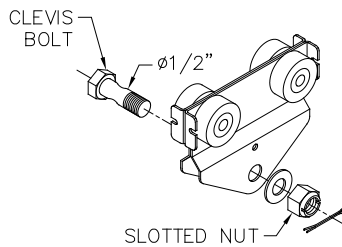

Diagram 6A. Installing hoist on A150 hoist trolley.

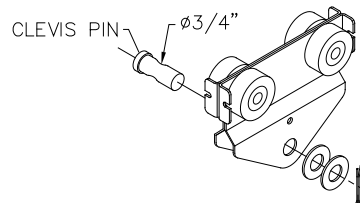

Diagram 6B. Installing hoist on A250-A500 hoist trolley.

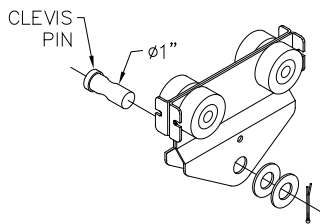

Diagram 6C. Installing hoist on A1000-A2000 hoist trolley.

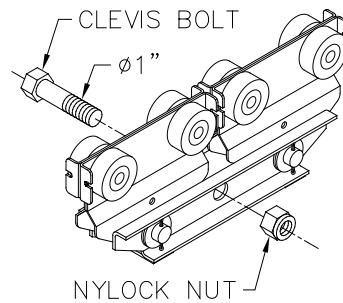

Diagram 6D. Installing hoist on A2000 loadbar hoist trolley.

Step 6 - Hoist Trolley Installation

Trolleys for Standard Applications (Continued)

6.6 Bend back both legs of cotter pin (**diagram 6E**).

WARNING: Fully bend both legs of the cotter pin on all clevis pins (**diagram 6E**). If cotter pin is cracked or fatigued it must be replaced.

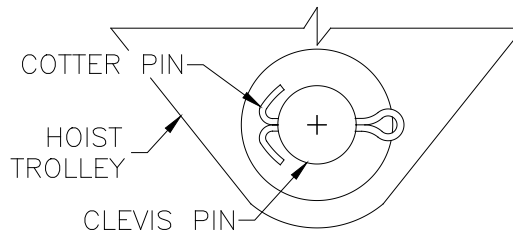

Diagram 6E. Installing cotter pin through trolley clevis pin.

6.7 Roll hoist trolley into open end of track on bridge/monorail.

6.8 Install endstop and endcap on the festooning end of bridge/monorail (refer to **diagram 3D**, on **page 7**).

6.9 If you do not have festooning, go to **Step 11**, on **page 28**.

If you do not have a festoon stack section, go to **Step 8**, on **page 21**. Otherwise, go to **Step 7**, on **page 20**.

Trolleys for Automotive Applications

6.10 Your trolley should look like this:

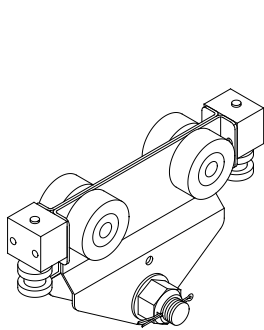

A150-A2000 series

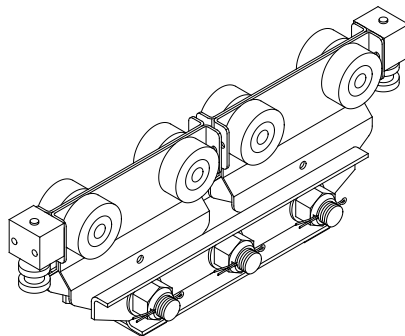

A2000 loadbar series

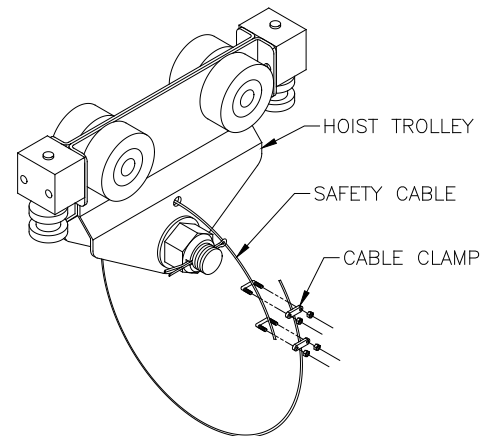

Diagram 6F. Installing safety cable on hoist trolley.

Step 6 - Hoist Trolley Installation

Trolleys for Automotive Applications (Continued)

- 6.11 Clean inside flanges of track with a clean, dry cloth (do not use any kind of cleaning solution) to remove grit or debris that may have collected during shipping, storage, or installation.
- 6.12 Be sure endstop is installed opposite the festooning end of the bridge/monorail.
- 6.13 Attach hoist to hoist trolley by snapping the hoist suspension hook over the clevis bolt of the hoist trolley.
- 6.14 If hoist suspension hook is too large or hoist has a suspension device other than a hook, you will need to remove the trolley clevis slotted nut and clevis bolt to install the suspension device (**diagrams 6G, 6H, 6I or 6J**).

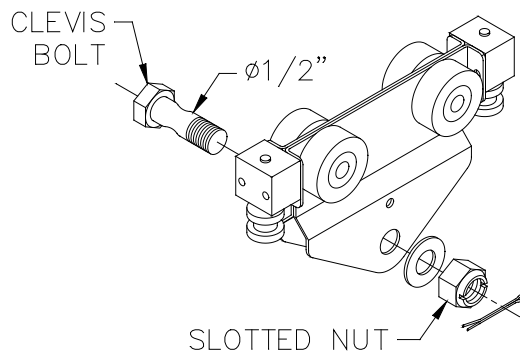

Diagram 6G. Installing hoist on A150 hoist trolley.

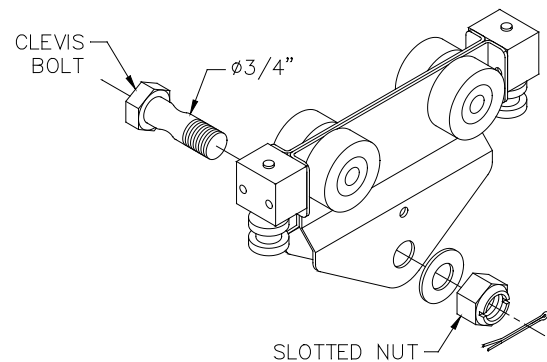

Diagram 6H. Installing hoist on A250-A500 hoist trolley.

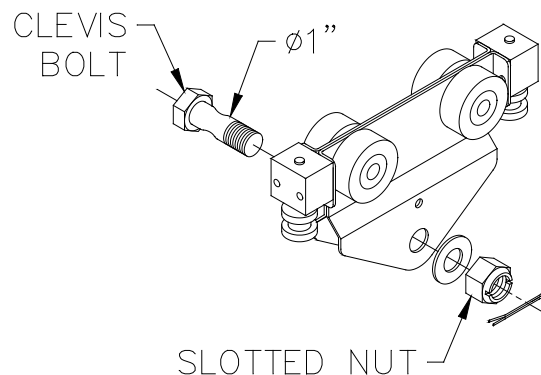

Diagram 6I. Installing hoist on A1000-A2000 hoist trolley.

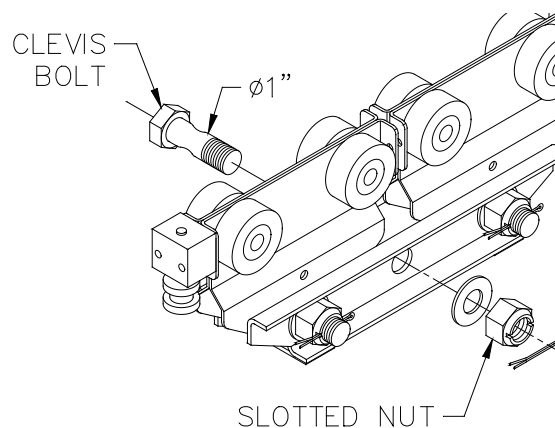

Diagram 6J. Installing hoist on A2000 loadbar hoist trolley.

Step 6 - Hoist Trolley Installation

Trolleys for Automotive Applications (Continued)

6.15 Install safety cable (**diagram 6F**).

6.16 Thread nut onto clevis bolt and insert cotter pin through trolley clevis bolt. Bend both legs of cotter pin (**diagram 6K**).

WARNING: Be sure that the ends of the cotter pin on all clevis pins are bent (**diagram 6K**). If cotter pin is cracked or fatigued it must be replaced.

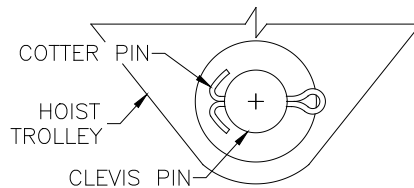

Diagram 6K. Installing cotter pin through trolley clevis pin.

6.17 Roll hoist trolley into open end of track on bridge/monorail.

6.18 Install endstop on the festooning end of bridge/monorail (refer to **diagram 3D**, on page 7).

6.19 If you do not have festooning, go to **Step 11**, on page 28.

If you do not have a festoon stack section, go to **Step 8**, on page 21. Otherwise, go to **Steps 7 and 8**, starting on page 20.

Step 7 - Festoon Stack Installation

IMPORTANT: Festoon stack section allows festooning to stack up at the end of system, permitting full use of runway/monorail.

7.1 Remove endstop on festooning end of runway/monorail.

7.2 Attach splice brackets to all track joints (2 per track end to be spliced) (**diagram 7A** on page 21).

Tighten hexnuts to the recommended ratings listed in **chart 2A**, on page 2.

7.3 Install “guide pins” (**diagram 7A** on page 21). The guide pins should be screwed into the track section so that no thread is showing. Do not screw the pins in too far. For ease of final splice assembly, be sure guide pins are installed straight.

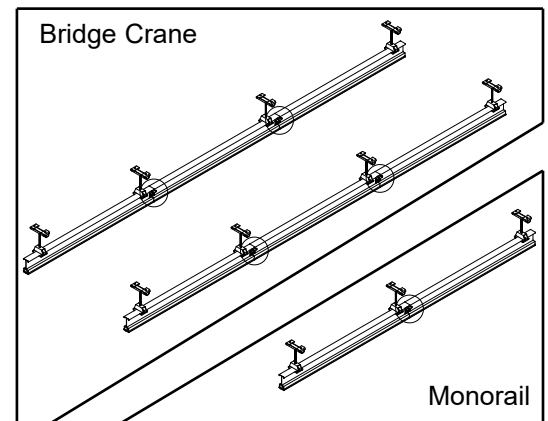

Step 7 - Festoon Stack Installation (Continued)

- 7.4 Lift the stack section into place, line up the guide pins, and use the “draw” bolts to bring the two sections of track together. Tighten hardware until lockwashers are fully compressed, and there is no gap between the track sections.
- 7.5 Re-install endstop (**diagram 7B**).

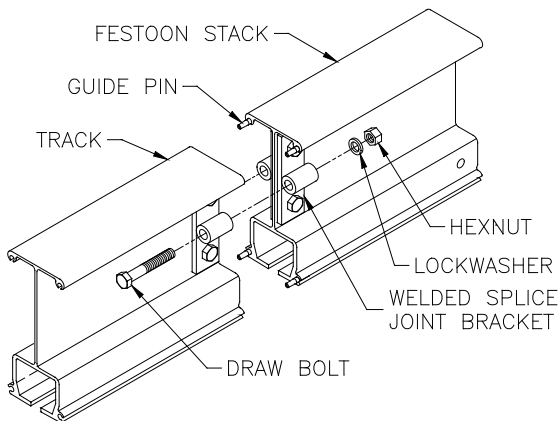

Diagram 7A. Installing festoon stack section.

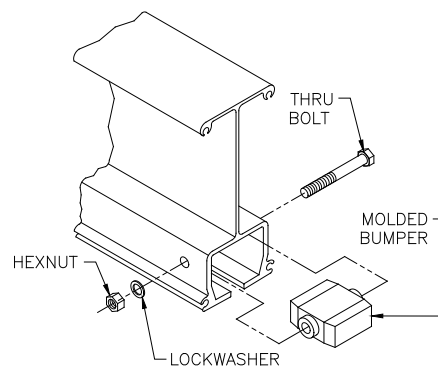

Diagram 7B. Re-installing endstop in track after installing festoon stack section.

Step 8 - Festooning Installation

NOTE: Enough carriers (festoon trolleys) are supplied to support festoon conductor every 6' on runway/monorail and every 3' on bridges. Note: Every 6' on vacuum hose trolley.

- 8.1 Locate festoon trolleys as shown in **diagram 8A**.

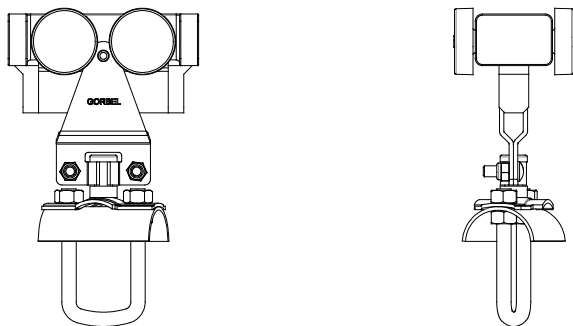
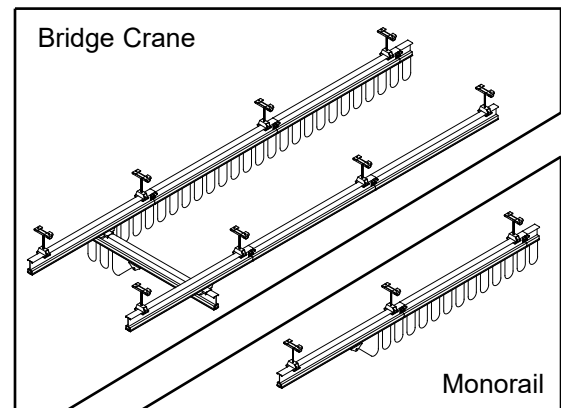

Diagram 8A. Festoon trolleys



Step 8 - Festooning Installation (Continued)

IMPORTANT: Before installing festoon trolleys in 250 and 500 series track, the molded bumper (on festooning end of bridge/runway) must first be removed.

Festoon Trolleys

If you have a monorail, go to **Step 8.6**.

- 8.2 For 250-500 series track: Remove endstop on festooning end of bridge.
- 8.3 Roll festoon trolleys through open end of bridge that corresponds with festooning on runway. Space festoon trolleys every 3'-0" along bridge. NOTE: Every 6'-0" for vacuum hose festooning.
- 8.4 Slide festoon clamp/vacuum hose clamp into place at festooning end of bridge and tighten clamp bolt (**diagrams 8B and 8C**).
- 8.5 Re-install endstop (molded bumper with thru bolt) in festooning end of bridge (**diagram 8D**).
- 8.6 For 250-500 series track: Remove endstop from festoon stack section/festooning end of runway/monorail.
- 8.7 Roll festoon trolleys into end of runway/monorail/festoon stack section track (on festooning side of runway/monorail). Space festoon trolleys every 6'-0" along runway/monorail, between bridge and festoon stack section.
- 8.8 Slide festoon clamp into end of runway/monorail/festoon stack section and tighten clamp bolt (**diagram 8B or 8C**).
- 8.9 For 250 or 500 series track: Re-install endstop in festoon stack section (**diagram 8D**).

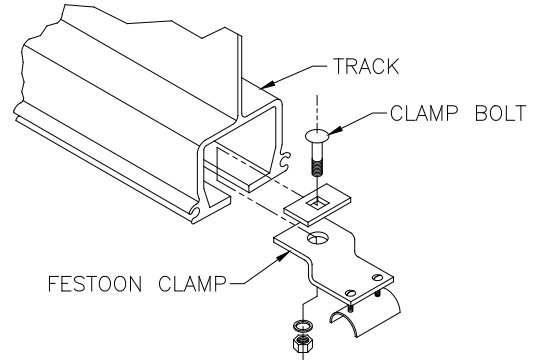

Diagram 8B. Installing clamp on runway or bridge.

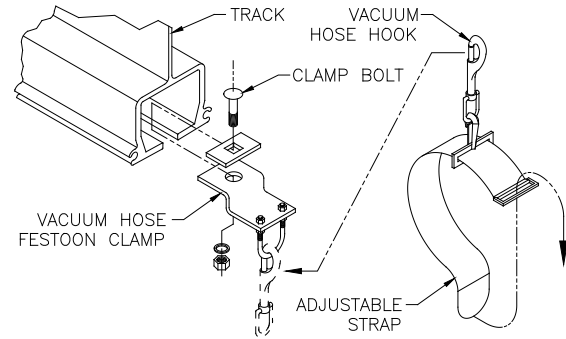

Diagram 8C. Installing vacuum hose clamp on runway or bridge.

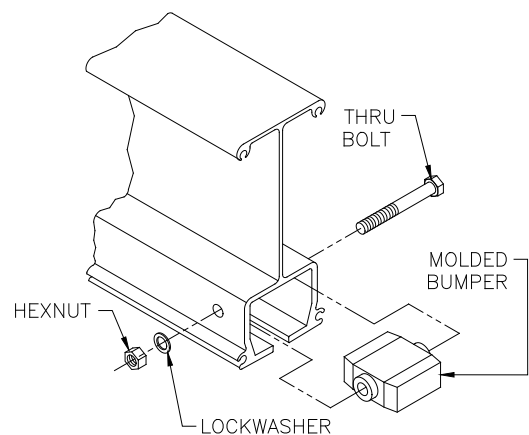

Diagram 8D. Installing endstop on runway/monorail/festoon stack section.

NOTE: Because trolleys are too large to roll under the endstop on the 250 and 500 series track, the endstop and accompanying hardware (which held the festoon stack section to the runway/monorail) is positioned at the end of the festoon stack section.

Step 8 - Festooning Installation (Continued)

WARNING: Crane cannot be utilized as a ground: A separate ground wire is required. For example, systems with 3-phase power require 3 conductors plus on ground wire.

8.10 **Installing Festoon Electric Cable/Air Hose/Vacuum Hose:** Festoon trolleys are designed to accept 4-conductor, electric flat or round cable (#12 or #14 gauge) or air hose (maximum: 7/8" outside diameter).

Electric Cable/Air Hose with Festoon Trolleys

Loosen nuts and clamp-plate enough to thread electric cable/air hose between the U-bolt legs and clamp plate on festoon trolley. Secure electric cable/air hose by tightening nuts on festoon clamp, forcing clamp plate snug against electric cable/air hose (**diagram 8E**).

NOTE: Be careful not to over tighten hardware; this will cause damage to electric cable/air hose.

NOTE: Be sure that U-bolt does not interfere with trolley body.

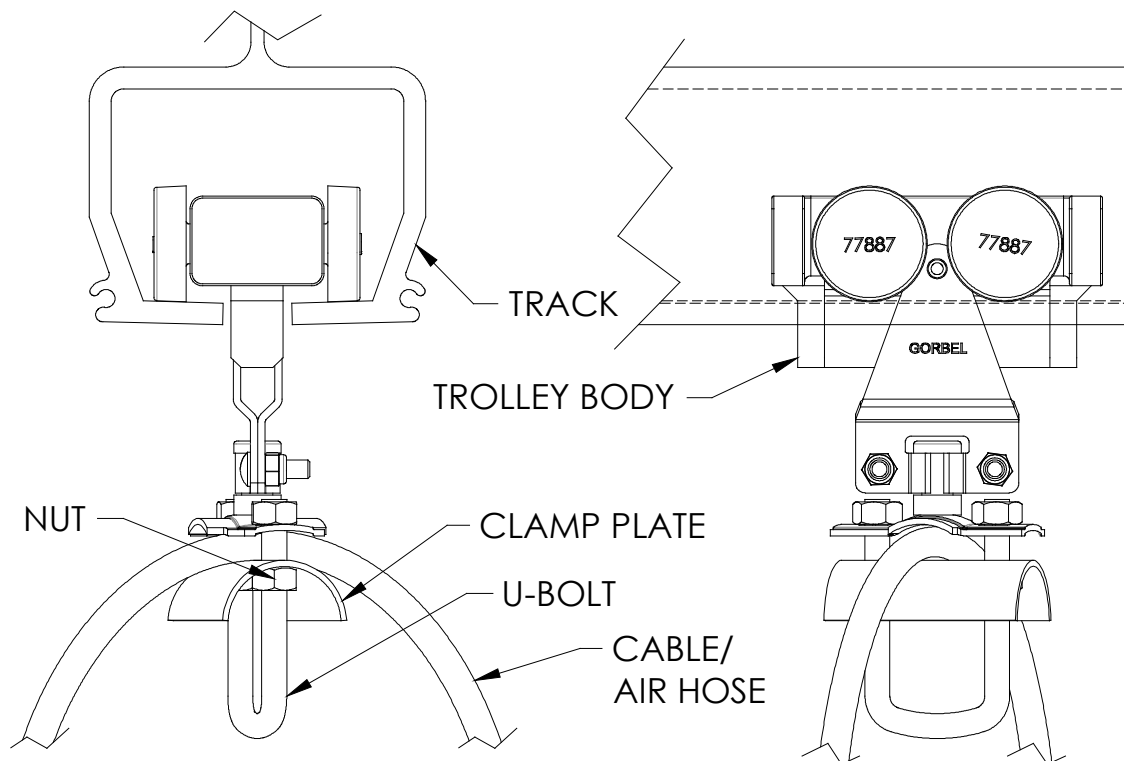

Diagram 8E. Installing electric cable or air hose on festoon trolley.

Step 8 - Festooning Installation (Continued)

Electric Cable/Air Hose with Festoon Trolleys (Continued)

IMPORTANT Cable/Air Hose Installation: It is important that as much twist as possible be taken out of the cable or hose before it is hung. To take the twist out follow the steps below:

1. Lay the cable or hose out on the floor flat.
2. Mark the cable or hose where the first end clamp will be and then make marks for trolley and bridge end clamp locations at 6-7 foot intervals. If cable or hose twist still exists, increase intervals.
3. Recoil the cable or hose so that the marks are all lined up on the top of the coiled cable or hose.
4. Lay the large coil on the floor with the marks lined up. At each mark, attach a trolley or end clamp. When installing the festoon, pick up the whole coil and run the trolleys in without disturbing the coil.

Vacuum Hose Trolleys

Place strap around vacuum hose (by others). Secure Velcro sides together and be sure vacuum hose is held snugly in place (**diagram 8F**).

NOTE: Strap will fit vacuum hoses with outside diameters ranging from 1-1/2" to 2-3/4".

Clip vacuum hose hook (with vacuum hose attached) onto vacuum hose trolley (**diagram 8F**).

NOTE: If Velcro strap does not hold vacuum hose securely, engage vacuum device so a vacuum is present in the hose and retighten Velcro straps so the vacuum hose is held tightly.

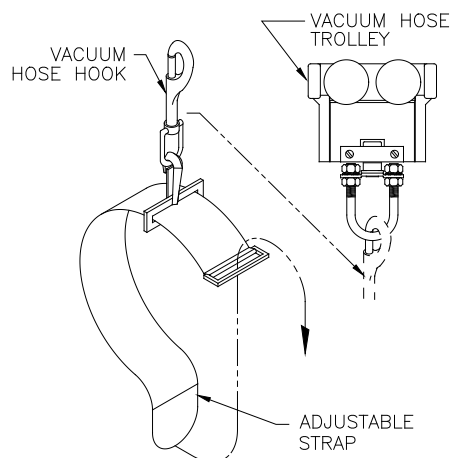

Diagram 8F. Installing vacuum hose on vacuum hose trolley.

Step 9 - Bridge and Runway Tagline Installation

Aluminum Track (Bridges and Runways)

9.1 Attach tagline brackets to aluminum track web (**diagrams 9A, 9B and 9C**).

NOTE: Do not forget to install the backing angle on the web opposite to the tagline angle.

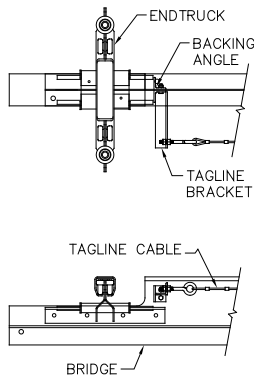

Diagram 9A. Tagline on coped aluminum bridge.

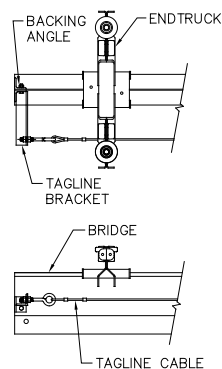

Diagram 9B. Tagline on non-coped aluminum bridge.

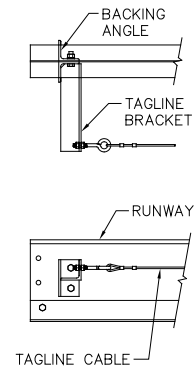

Diagram 9C. Tagline on aluminum runway.

9.2 Attach eyebolts onto tagline brackets. Attach turnbuckle to one eyebolt. Loop cable through eyebolt or turnbuckle and turn back 4-3/4" of cable on a thimble. Apply first clamp 1" from the dead end of the cable and tighten U-bolt to 15 ft.-lbs. or torque. Apply the second clamp as close to thimble as possible. Tighten U-bolt to 15 ft.-lbs. or torque (**diagram 9D**).

9.3 Add any S-hooks, wire rope trolleys, or coiled air hose to the cable prior to attaching the other end.

9.4 Secure other end of the cable.

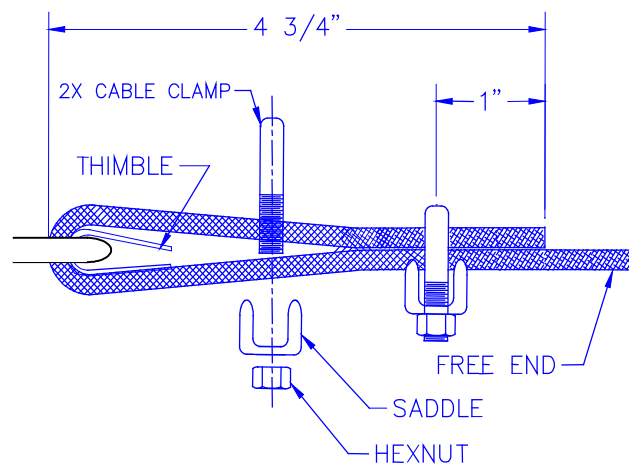

Diagram 9D. Saddling the cable on one end.

Step 10 - Optional Accessories

Safety Cable Installation

- A) The safety cable is provided as a single piece and must be cut in the field as necessary. Each connection requires 5 ft. of cable.
- B) After cutting the cable down to required length, one end of each cable must be properly saddled using the thimble and U-bolt cable clamps provided (**diagram 10A**).
- C) Turn back 4-3/4" of cable on a thimble or loop. Apply the first clamp 1" from the dead end of the cable and tighten U-bolt to 15 ft.-lbs. of torque. Apply the second clamp as close to thimble or loop as possible. Tighten U-bolt to 15 ft.-lbs. of torque (**diagram 10A**).
- D) Pass the free end of cable through support points of each connection in which safety cabling is required.
- E) After the free end of cable has passed through all required support points, it should be passed through the saddled end of cable.
- F) Saddle the free end of cable while making sure both ends are interlocked. Complete the connection using the instructions from Step C above (**diagram 10B**).

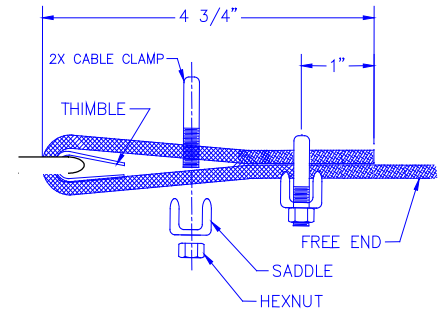

Diagram 10A. Saddling the cable on one end.

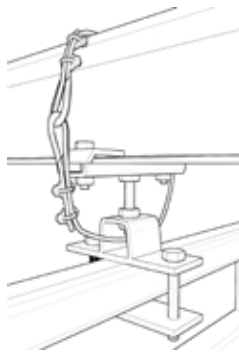

Diagram 10B. Safety cable installed on ceiling mounted hanger connection.

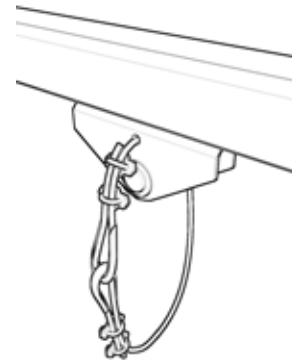

Diagram 10C. Safety cable installed on Gorbels® trolley that will attach to hoist (by others).

WARNING: The cable and termination should be inspected periodically for wear, abuse, and general adequacy.

Step 10 - Optional Accessories

Coiled Air Hose Installation

- A) Assemble female fittings to the coiled air hose according to **diagram 10D**. The coiled air hose is inserted through the spring guard, nut, ferrule, and over the tube insert as far as possible. Note the orientation of the ferrule: the bevel is pointing towards the female fitting.

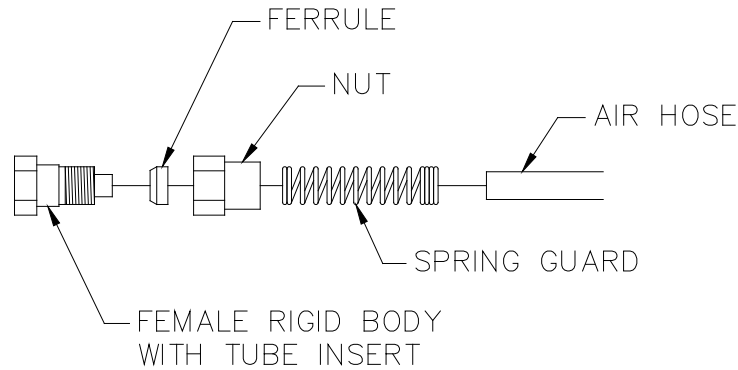

Diagram 10D. Female fitting assembly.

- B) Assemble the remainder of the components per **diagram 10E**.

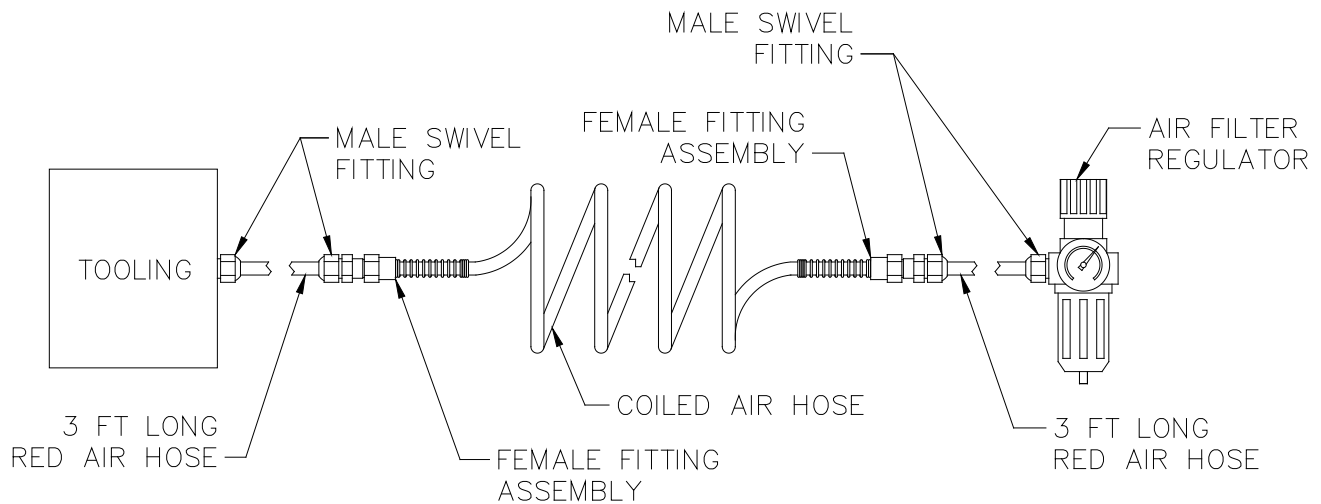

Diagram 10E. Coiled air hose assembly.

Step 11 - Final Steps

IMPORTANT: Do not throw away this manual: the maintenance schedule is on the back cover.

- 11.1 Check to make sure all bolts are tightened to specifications and lockwashers are flat.
- 11.2 Once all end trucks, trolleys and end stops are installed, confirm that the trolleys/end trucks contact the end stops appropriately and are not at risk of rolling past the stops.
- 11.3 Be sure to sway brace the crane.
- 11.4 If necessary, touch up crane with paint provided (some aluminum systems are painted).
- 11.5 Keep Packing List, Installation Manual, General Arrangement Drawing, and any other inserts filed together in a safe place, for future reference.

Applied Forces to the Supporting Structure

The applied forces drawing in **diagram 1**, details the relative position and the direction of forces that the work station bridge crane applies to the supporting structure.

Loads applied to the support structure can be determined by the following formulas:

P	=	Live Load
R1	=	Vertical Load applied by support hanger (lb.)
R2	=	Longitudinal load applied by movement of the crane to each runway (lb.)
R3	=	Lateral load applied by movement of the trolley and load to each runway (lb.)
L	=	Distance between support centers (ft.)
L4	=	Bridge span (center line distance of runways) (ft.)
1.4	=	Design factor which includes 25% for impact and 15% for hoist weight
W	=	Weight per foot of runway (lb./ft.)
w	=	Weight per foot of bridge (lb./ft.)
R1	=	$(1.4 * P) + (W * L) + \frac{(w * L4)}{2}$

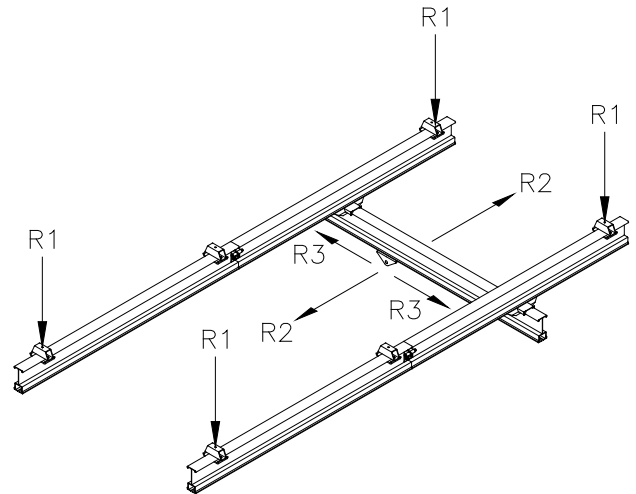

Diagram 1. Applied forces to supporting structures.

NOTE: If there are only 2 hangers per runway substitute “L/2” for L in the R1 formula.

$$R2 = (1.15 * P) + [(w * L^4) * 0.10]$$

$$R3 = 1.15 * P * 0.20$$

TRACK WEIGHT PER FOOT (LB)					
Track Type	150 Series	250 Series	500 Series	1000 Series	2000 Series
AL	2.16#	4.00#	4.70#	8.30#	10.20#

Step 12 - Sway and Thrust Bracing Guidelines

WARNING: Bracing must be installed to resist damaging lateral and longitudinal loads.

Sway bracing must be located at or near each support location. It is required that each sway brace point shall not exceed the smaller of 10% of the spacing between supports or 24 inches from a support point. Maximum spacing shall not exceed 30 feet or as determined by structural analysis involving maximum unbraced length of the compression flange, and the horizontal length and horizontal deflection limit of the track.

Thrust bracing must be located at or near end hanger locations. It is required that each thrust brace point shall not exceed the smaller of the 10% of the spacing between supports or 24 inches from a support point. At a minimum, there should be two thrust braces per enclosed track runway. At curved locations (used with monorails) bracing shall be provided at ends and midpoint of curves, but the maximum spacing shall not exceed three feet. On monorail systems, track switches shall be braced in both directions.

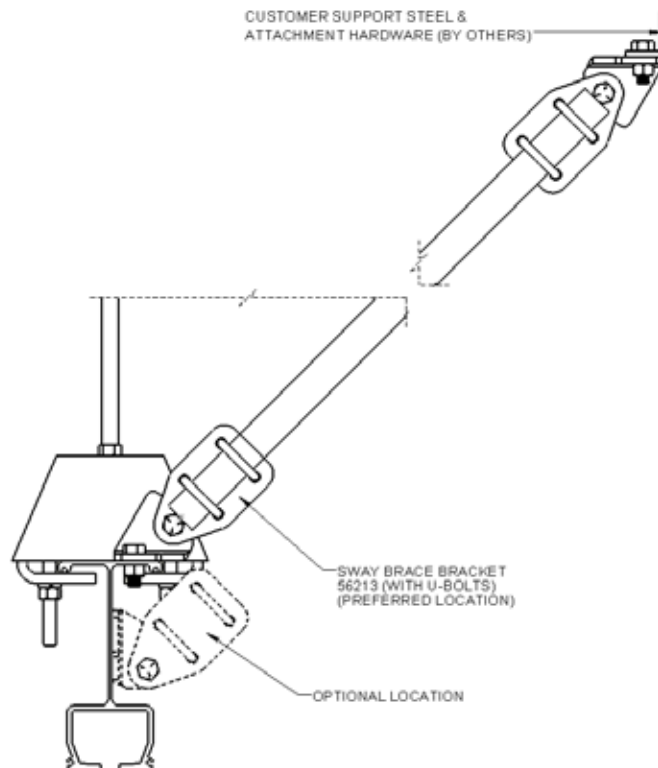
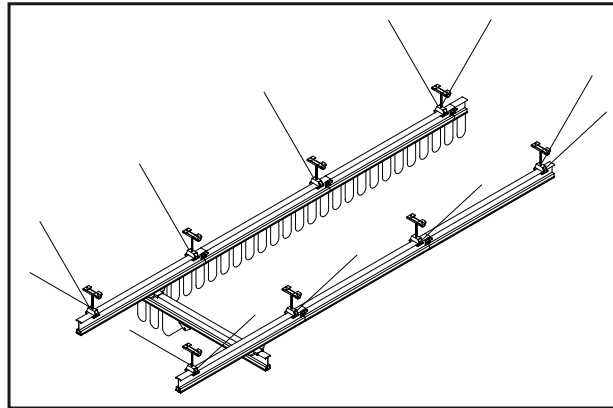

Sway and Thrust Bracing Guidelines (Continued)

Sway or thrust bracing must not be directly attached to hanger rods. All new bracing connecting to the flange of the track and flanges of building beams shall use sway brackets or equal (**diagram 2**). When attaching bracing to steel hoist or steel beams, the bracing member shall be attached to the top chord or tip flange and located as close to the bridging members as possible.

Angle of bracing from vertical preferably should be equal to or greater than 45 degrees, but in no case be less than 30 degrees. Generally, bracing is placed either parallel or perpendicular to track. However, skewed bracing is also permissible to accommodate difficult connections, such as the presence of ducts or pipes. Design of skewed bracing should use the same criteria for parallel/perpendicular bracing. For skewed thrust bracing, two pieces, symmetrical to the track, should be used if the skewed angle is greater than 10 degrees.

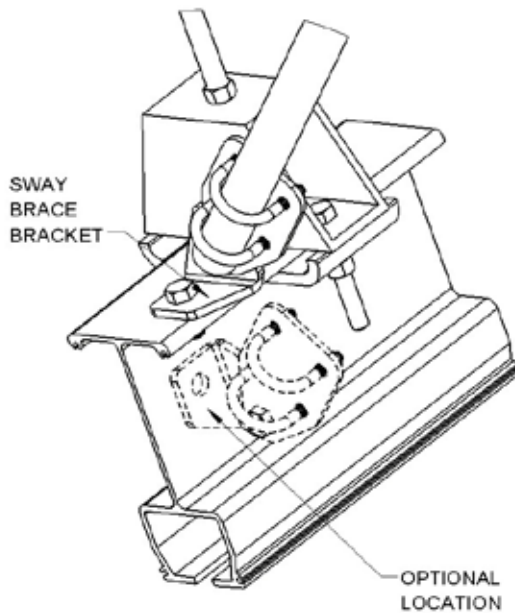

Diagram 2. Typical connection detail. Field drilling required.

ANGLE AND PIPE BRACE TYPES Based on $(KL/r = 300)$ Design Criteria

Size	Area (in ²)	r (in)	Max. Length (ft)	Allowable Force (kips)
1" Ø pipe SCH 40	0.49	0.421	10.5	0.81
1" Ø pipe SCH 80	0.64	0.407	10.17	1.06
L 2" x 2" x 1/4"	0.94	0.609	15.23	1.56
L 2 1/2" x 2 1/2" x 1/4"	1.19	0.769	19.23	1.97
L 3" x 3" x 1/4"	1.44	0.930	23.25	2.39

K = Effective Length Factor for a Prismatic Member (see AISC manual)

L = Length of Brace

r = Radius of Gyration

Crane Operator Instructions

Overhead cranes and jib cranes generally handle materials over working areas where there are personnel. Therefore, it is important for the Crane Operator to be instructed in the use of the crane and to understand the severe consequences of careless operation. It is not intended that these suggestions take precedence over existing plant safety rules and regulations or OSHA regulations. However, a thorough study of the following information should provide a better understanding of safe operation and afford a greater margin of safety for people and machinery on the plant floor. It must be recognized that these are suggestions for the Crane Operator's use. It is the responsibility of the owner to make personnel aware of all federal, state and local rules and codes, and to make certain operators are properly trained.

Qualifications

Crane operation, to be safe and efficient, requires skill: the exercise of extreme care and good judgment, alertness and concentration, and rigid adherence to proven safety rules and practices as outlined in applicable and current ANSI and OSHA safety standards. In general practice, no person should be permitted to operate a crane:

- Who cannot speak the appropriate language or read and understand the printed instructions.
- Who is not of legal age to operate this type of equipment.
- Whose hearing or eyesight is impaired (unless suitably corrected with good depth perception).
- Who may be suffering from heart or other ailments which might interfere with the operator's safe performance.
- Unless the operator has carefully read and studied this operation manual.
- Unless the operator has been properly instructed.
- Unless the operator has demonstrated his instructions through practical operation.
- Unless the operator is familiar with hitching equipment and safe hitching equipment practices.

Handling the Bridge Travel Motion

Before using the bridge of the crane, the operator should be sure the hook is high enough to clear any obstruction. Before a load is handled by the crane, the bridge should be brought into position so that it is directly over the load. Start the bridge slowly and bring it up to speed gradually. Approaching the place where it is desired to stop the bridge, reduce the bridge speed.

Handling the Trolley Motion

Before a load is handled, the hoist should be positioned directly over the load that is to be handled. When the slack is taken out of the slings, if the hoist is not directly over the load, bring it directly over the load before hoisting is continued. Failure to center the hoist over the load may cause the load to swing upon lifting. Always start the trolley motion slowly and reduce the trolley speed gradually.

Handling the Hoist Motion

Refer to the lifting (hoist) equipment's operating instructions.

General Suggestions

Know Your Crane

Crane operators should be familiar with the principal parts of a crane and have a thorough knowledge of crane control functions and movements. The crane operator should be required to know the location and proper operation of the main conductor disconnecting means for all power to the attachments on the crane.

Responsibility

Each crane operator should be held directly responsible for the safe operation of the crane. Whenever there is any doubt as to SAFETY, the crane operator should stop the crane and refuse to handle loads until: (1) safety has been assured or (2) the operator has been ordered to proceed by the supervisor, who then assumes all responsibility for the SAFETY of the lift. Do not permit ANYONE to ride on the hook or a load.

Inspection

Test the crane movement and any attachments on the crane at the beginning of each shift. Whenever the operator finds anything wrong or apparently wrong, the problem should be reported immediately to the proper supervisor and appropriate corrective action taken.

Operating Suggestions

One measure of a good crane operator is the smoothness of the crane operation. The good crane operator should know and follow these proven suggestions for safe, efficient crane handling.

1. The crane should be moved smoothly and gradually to avoid abrupt, jerky movements of the load. Slack must be removed from the sling and hoisting ropes before the load is lifted.
2. Center the crane over the load before starting the hoist to avoid swinging the load as the lift is started. Loads should not be swung by the crane to reach areas not under the crane.
3. Crane-hoisting ropes should be kept vertical. Cranes shall not be used for side pulls.
4. Be sure everyone in the immediate area is clear of the load and aware that a load is being moved.
5. Do not make lifts beyond the rated load capacity of the crane, sling chains, rope slings, etc.
6. Make certain that before moving the load, load slings, load chains, or other lifting devices are fully seated in the saddle of the hook with hook latch closed (if equipped with hook latch).
7. Check to be sure that the load and/or bottom block is lifted high enough to clear all obstructions when moving boom or trolley.
8. At no time should a load be left suspended from the crane unless the operator has the push button with the power on, and under this condition keep the load as close as possible to the floor to minimize the possibility of an injury if the load should drop. When the crane is holding a load, the crane operator should remain at the push button.
9. Do not lift loads with sling hooks hanging loose. If all sling hooks are not needed, they should be properly stored, or use a different sling.
10. All slings or cables should be removed from the crane hooks when not in use (dangling cables or hooks hung in sling rings can inadvertently snag other objects when the crane is moving).
11. Operators shall not carry loads and/or empty bottom blocks over personnel. Particular additional caution should be practiced when using magnet or vacuum devices. Loads, or parts or loads, held magnetically could drop. Failure of power to magnets or vacuum devices can result in dropping the load. Extra precaution should be exercised when handling molten metal in the proximity of personnel.
12. Whenever the operator leaves the crane the following procedure should be followed:
 - Raise all hooks to an intermediate position.
 - Spot the crane at an approved designated location.

- Place all controls in the “off” position.
 - Open the main switch to the “off” position.
 - Make visual check before leaving the crane.
13. In case of emergency or during inspection, repairing, cleaning or lubrication, a warning sign or signal should be displayed and the main switch should be locked in the “off” position. This should be done whether the work is being done by the crane operator or by others.
 14. Contact with rotation stops or trolley end stops shall be made with extreme caution. The operator should do so with particular care for the safety of persons below the crane, and only after making certain that any persons on the other cranes are aware of what is being done.
 15. ANY SAFETY FEATURES AND MECHANISMS BUILT-IN OR OTHERWISE PROVIDED WITH THE CRANE BY GORBEL[®] ARE REQUIRED FOR THE SAFE OPERATION OF THE CRANE. DO NOT, UNDER ANY CIRCUMSTANCES, REMOVE OR OTHERWISE IMPAIR OR DISABLE THE PROPER FUNCTIONING OF ANY CRANE SAFETY MECHANISMS OR FEATURES BUILT-IN OR OTHERWISE PROVIDED BY GORBEL[®] FOR SAFE OPERATION OF THE CRANE.
 16. ANY REMOVAL, IMPAIRMENT OR DISABLING OF ANY SUCH SAFETY MECHANISMS OR FEATURES OR OTHER USE OR OPERATION OF THE CRANE WITHOUT THE COMPLETE AND PROPER FUNCTIONING OF ANY SUCH SAFETY MECHANISMS OR FEATURES AUTOMATICALLY AND IMMEDIATELY AVOIDS ANY AND ALL EXPRESS AND IMPLIED WARRANTIES OF ANY KIND OR NATURE.

Limited Warranty

It is agreed that the equipment purchased hereunder is subject to the following LIMITED warranty and no other. Gorbel® Incorporated (“Gorbel®”) warrants the manual push-pull Work Station Cranes, Jib Crane, Gantry Crane, and Tether Track® products to be free from defects in material or workmanship for a period of ten years or 20,000 hours use from date of shipment. Gorbel® warrants the Motorized Work Station Cranes and Jib Crane products to be free from defects in material or workmanship for a period of two years or 4,000 hours use from the date of shipment. Gorbel® warrants the G-Force® and Easy Arm® products to be free from defects in material or workmanship for a period of one year or 2,000 hours use from the date of shipment. This warranty does not cover Gantry Crane wheels. This warranty shall not cover failure or defective operation caused by operation in excess of recommended capacities, misuses, negligence or accident, and alteration or repair not authorized by Gorbel®. No system shall be field modified after manufacture without the written authorization of Gorbel® Inc. Any field modification made to the system without the written authorization of Gorbel® Inc. shall void Gorbel®’s warranty obligation.

OTHER THAN AS SET FORTH HEREIN, NO OTHER EXPRESS WARRANTIES, AND NO IMPLIED WARRANTIES, ORAL OR WRITTEN, INCLUDING BUT NOT LIMITED TO THE WARRANTIES OF MERCHANTABILITY OR FITNESS FOR A PARTICULAR PURPOSE, ARE MADE BY GORBEL® WITH RESPECT TO ITS PRODUCTS AND ALL SUCH WARRANTIES ARE HEREBY SPECIFICALLY DISCLAIMED. GORBEL® SHALL NOT BE LIABLE UNDER ANY CIRCUMSTANCES FOR ANY INCIDENTAL, SPECIAL AND/OR CONSEQUENTIAL DAMAGES WHATSOEVER, WHETHER OR NOT FORESEEABLE, INCLUDING BUT NOT LIMITED TO DAMAGES FOR LOST PROFITS AND ALL SUCH INCIDENTAL, SPECIAL AND/OR CONSEQUENTIAL DAMAGES ARE HEREBY ALSO SPECIFICALLY DISCLAIMED.

Gorbel®’s obligation and Purchaser’s or end user’s sole remedy under this warranty is limited to the replacement or repair of Gorbel®’s products at the factory, or at the discretion of Gorbel®, at a location designated by Gorbel®. Purchaser or end user shall be solely responsible for all freight and transportation costs incurred in connection with any warranty work provided by Gorbel® hereunder. Gorbel® will not be liable for any loss, injury or damage to persons or property, nor for damages of any kind resulting from failure or defective operation of any materials or equipment furnished hereunder.

Components and accessories not manufactured by Gorbel® are not included in this warranty. Purchaser’s or end user’s remedy for components and accessories not manufactured by Gorbel® is limited to and determined by the terms and conditions of the warranty provided by the respective manufacturers of such components and accessories.

A) DISCLAIMER OF IMPLIED WARRANTY OF MERCHANTABILITY

Gorbel® and Purchaser agree that the implied warranty of merchantability is excluded from this transaction and shall not apply to the goods involved in this transaction.

B) DISCLAIMER OF IMPLIED WARRANTY OF FITNESS FOR PARTICULAR PURPOSE

Gorbel® and Purchaser agree that the implied warranty of fitness for particular purpose is excluded from this transaction and shall not apply to the goods involved in this transaction.

C) DISCLAIMER OF EXPRESS WARRANTY

Gorbel®’s agents, or dealer’s agents, or distributor’s agents may have made oral statements about the machinery and equipment described in this transaction. Such statements do not constitute warranties, and Purchaser agrees not to rely on such statements. Purchaser also agrees that such statements are not part of this transaction.

D) DISCLAIMER OF SPECIAL, INCIDENTAL AND CONSEQUENTIAL DAMAGES

Gorbel® and Purchaser agree that any claim made by Purchaser which is inconsistent with Gorbel®'s obligations and the warranty remedies provided with Gorbel®'s products, and in particular, special, incidental and consequential damages, are expressly excluded.

E) DEALER OR DISTRIBUTOR NOT AN AGENT

Gorbel® and Purchaser agree that Purchaser has been put on notice that dealer or distributor is not Gorbel®'s agent in any respect for any reason. Gorbel® and Purchaser also agree that Purchaser has been put on notice that dealer or distributor is not authorized to incur any obligations or to make any representations or warranties on Gorbel®'s behalf other than those specifically set forth in Gorbel®'s warranty provided in connection with its product.

F) MERGER

This warranty agreement constitutes a final and complete written expression of all the terms and conditions of this warranty and is a complete and exclusive statement of those terms.

G) PAINTING

Every crane (excluding components) receives a quality paint job before leaving the factory. Unfortunately, no paint will protect against the abuses received during the transportation process via common carrier. We have included at least one (1) twelve ounce spray can for touchup with each crane ordered (unless special paint was specified). If additional paint is required, contact a Gorbel® Customer Service Representative at 1-800-821-0086 or 1-585-924-6262.

Title and Ownership:

Title to the machinery and equipment described in the foregoing proposal shall remain with Gorbel® and shall not pass to the Purchaser until the full amount herein agreed to be paid has been fully paid in cash.

Claims and Damages:

Unless expressly stated in writing, goods and equipment shall be at Purchaser's risk on and after Seller's delivery in good shipping order to the Carrier. Gorbel® shall in no event be held responsible for materials furnished or work performed by any person other than it or its authorized representative or agent.

Cancellations:

If it becomes necessary for the purchaser to cancel this order wholly or in part, he shall at once so advise Gorbel® in writing. Upon receipt of such written notice all work will stop immediately. If the order entails only stock items, a flat restocking charge of 15% of the purchase price will become due and payable by Purchaser to Gorbel®. Items purchased specifically for the canceled order shall be charged for in accordance with the cancellation charges of our supplier plus 15% for handling in our factory. The cost of material and/or labor expended in general fabrication for the order shall be charged for on the basis of total costs to Gorbel® up to the time of cancellation plus 15%.

Returns:

No equipment, materials or parts may be returned to Gorbel® without express permission in writing to do so.

Extra Charge Delay: If Purchaser delays or interrupts progress of Seller's performance, or causes changes to be made, Purchaser agrees to reimburse Gorbel® for expense, if any, incident to such delay.

Changes and Alterations:

Gorbel® reserves the right to make changes in the details of construction of the equipment, as in its judgment, will be in the interest of the Purchaser; will make any changes in or additions to the equipment which may be agreed upon in writing by the Purchaser; and Gorbel® is not obligated to make such changes in products previously sold any customer.

Third Party Action:

Should Gorbel® have to resort to third party action to collect any amount due after thirty (30) days from date of invoice, the Purchaser agrees to pay collection costs, reasonable attorney's fees, court costs and legal interest.

OSHA Responsibilities:

Gorbel® agrees to fully cooperate with Purchaser in the design, manufacture or procurement of safety features or devices that comply with OSHA regulations. In the event additional equipment or labor shall be furnished by Gorbel®, it will be at prices and standard rates then in effect, or as may be mutually agreed upon at the time of the additional installation.

Equal Employment Opportunity:

Gorbel® agrees to take affirmative action to ensure equal employment opportunity for all job applicants and employees without regard to race, color, age, religion, sex, national origin, handicap, veteran, or marital status. Gorbel® agrees to maintain non-segregated work facilities and comply with rules and regulations of the Secretary of Labor or as otherwise provided by law or Executive Order.

Inspection and Maintenance Schedule

Gorbel® Work Station Crane and Monorail: Inspection and Maintenance Schedule			
ITEM	COMPONENT	MAINTENANCE	FREQUENCY*
1	Top Hanger Bracket Beam Clips/Threaded Rod	Check that lockwashers are compressed and nuts tightened to torque specifications (chart 2A, page 2).	Every 2,000 hours or yearly
2	Lower Hanger Bracket	Check that lockwashers are compressed and nuts tightened to torque specifications (chart 2A, page 2).	Every 2,000 hours or yearly
3	Splice Joint	Check that lockwashers are compressed and nuts tightened to torque specifications (chart 2A, page 2). Check track for alignment and that wheel rolling surface is flush.	Every 2,000 hours or yearly
4	Hoist Trolley	Check clevis pin for wear. Cotter pin should be fully wrapped around clevis pin. Replace cotter pin if cracked or fatigued. Check clevis bolt and hardware.	Every 2,000 hours or yearly
5	End Stops (runway/bridge/monorail)	Check for full compressions of lockwasher. If thru-bolt is exposed, replace endstops.	Every 2,000 hours or yearly
6	Festoon Cable Clamp or Vacuum Hose Clamp	Check for full compression of lockwasher.	Every 2,000 hours or yearly
7	Wheels	Check for cracks, pits, and/or grooves. All of these increase pull forces. If any of these conditions exist, wheels should be replaced.	Every 2,000 hours or yearly
8	Shear Lug Hardware	Verify that shear lug is correctly installed. Check that lockwashers are compressed and nuts are tight.	Every 1,000 hours or 6 months
9	Aluminum Bridge Assembly Hardware	Check that lockwashers are compressed and nuts tightened to torque specifications (chart 2A, page 2).	Every 2,000 hours or yearly

*Federal, state and local codes may require inspection and maintenance checks more often. Please check the federal, state and local codes in your area.

WARNING: Any changes in rolling effort or unusual noises must be immediately identified and corrected. It is not necessary to lubricate the track or bearings. Lubricating may attract airborne particles and may increase the rolling resistance. (Do not use such substances as WD40, silicone sprays, oil or grease).



U.S. Patent No: US05694857
U.S. Patent No: US05443151

WARNING

This product contains chemicals known to the State of California to cause cancer and birth defects or other reproductive harm.

For more information: www.P65Warnings.ca.gov



600 Fishers Run, P.O. Box 593
Fishers, NY 14453-0593
Phone: (800) 821-0086
Fax: (800) 828-1808
E-Mail: info@gorbel.com
<http://www.gorbel.com>
©2026 Gorbel, Inc.
All Rights Reserved