

Aluminum Wall Bracket Jib Crane

Installation, Operation & Maintenance Manual

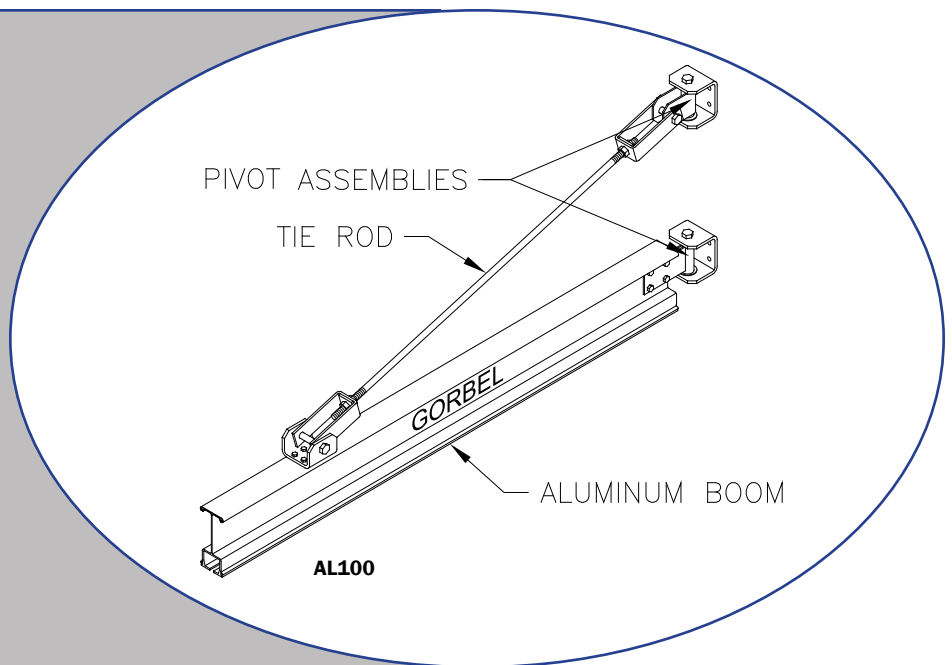

Part Number: MAN-US032-R03 Released 3/2026
Find manual updates at:
<https://www.gorbel.com/service-support/archived-installation-manuals>



Scan to Register
Your Warranty

Gorbel[®] Customer Order No. / Serial No.

Gorbel[®] Dealer

TABLE OF CONTENTS

Introduction.....	1
Installation	
Step 1 - Pre-assembly.....	2
Step 2 - Boom Installation	3 - 4
Step 3 - Hoist Trolley Installation	5
Step 4 - Festooning Installation.....	6
Step 5 - Accessories (Optional).....	7
Step 6 - Final Steps.....	7
Crane Operator Instructions.....	8
General Safety Suggestions.....	8
Warranty.....	9
Inspection and Maintenance Schedule	10

Questions? Concerns? Comments? Please call (800) 821-0086 (US and Canada) or (585) 924-6262 (outside US).

INTRODUCTION

Thank you for choosing Gorbel® Aluminum Jib Cranes to solve your material handling needs. The innovative design and heavy duty construction of Gorbel® Aluminum Jib Cranes provides a superior quality product and offer years of long term value. The hoist and trolley weight allowance is 15% of the crane capacity (for example, a crane rated for 1000 pounds allows for a 1000-pound live load, plus 150 pounds for the weight of the hoist and trolley). There is also an allowance of 25% of the crane capacity for impact caused by use of the hoist. Gorbel® Aluminum Jib Cranes will provide many years of dependable service by following the installation and maintenance procedures described herein.

Dimensions contained in this installation manual are for reference only and may differ for your particular application.

Normal safety precautions: These include, but are not limited to:

- Checking for obstructions in crane rotation.
- Checking that all bolts are tight and have lockwashers.
- Making sure that endstops are in place.
- Making sure that festooning cannot be snagged or pinched.

For additional safety precautions see page 8.

WARNINGS

1. Only competent erection personnel familiar with standard fabrication practices should be employed to assemble these cranes because of the necessity of properly interpreting these instructions. Gorbel is not responsible for the quality of workmanship employed in the installation of a crane according to these instructions. Contact Gorbel, Inc., at 600 Fishers Run, P.O. Box 593, Fishers, New York 14453-0593, 1-800-821-0086 or 1-585-924-6262, for additional information if necessary.
2. Equipment described herein is not designed for, and should not be used for, lifting, supporting or transporting humans. Failure to comply with any one of the limitations noted herein can result in serious bodily injury and/or property damage. Check Federal, State and Local regulations for any additional requirements.
3. Reference the American Institute of Steel Construction (AISC) manual (9th edition) for proper procedures to follow when using any torque tightening method.
4. Unless otherwise specifically stated, Gorbel® parts and products are designed for indoor use. Storing and/or using your items outside (even if covered), exposed to the elements, or in any method other than intended, may void all or some of the product warranty. Always store Gorbel® parts and products indoors, in a cool and dry area.

INSTALLATION

STEP 1 - PRE-ASSEMBLY

➔ **TIP:** Packing list can be found in plastic pocket inside hardware box.

- 1.1 Read entire manual **before** beginning installation of crane.
- 1.2 Check packing list to ensure no parts have been lost prior to initializing assembly of crane.
- 1.3 Tools and materials (by others) often needed to assemble crane are as follows:
 - Torque wrench
 - Leveling tools and plumb bob
 - Hand tools
 - Lifting device to lift heavy booms
 - Steel shims
 - Mounting hardware (by others, grade 5 bolts or better)
- 1.4 Determine:
 - Thrust and pull (**diagram 1A**, below, and **chart 1A**, page 2)

WARNING

Consult a qualified structural engineer to determine if your support structure is adequate to support the thrust and pull of your crane.

- Bracket centers (**chart 1A** & **diagram 1B**, page 2)
- Bolt pattern and dimensions (**diagrams 1B**, **1C**, and **chart 1B**, page 2)

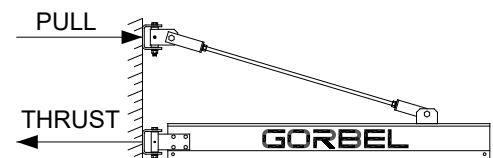

Diagram 1A. Thrust and pull definition.

STEP 1 - PRE-ASSEMBLY (CONTINUED)

Capacity (lbs.)	Span (ft)	Track Series	B	D	Thrust & Pull
			in	in	
150#	4'	A0250	18"	12"	511#
	6'	A0250	21"	15"	701#
	8'	A0250	24"	18"	852#
	10'	A0250	27"	21"	976#
	12'	A0250	30"	24"	1,081#
	14'	A0250	33"	27"	1,173#
	16'	A0250	36"	30"	1,256#
	18'	A0250	39"	33"	1,330#
	20'	A0250	42"	36"	1,399#
250#	4'	A0250	18"	12"	838#
	6'	A0250	21"	15"	1,141#
	8'	A0250	24"	18"	1,377#
	10'	A0250	27"	21"	1,567#
	12'	A0250	30"	24"	1,725#
	14'	A0250	33"	27"	1,861#
	16'	A0250	36"	30"	1,979#
	18'	A0250	39"	33"	2,084#
	20'	A0250	42"	36"	2,179#
500#	4'	A0500	24"	12"	1,244#
	6'	A0500	30"	15"	1,574#
	8'	A0500	36"	18"	1,800#
	10'	A0500	42"	21"	1,967#
	12'	A0500	48"	24"	2,097#
	14'	A0500	54"	27"	2,202#
	16'	A0500	60"	30"	2,290#
	18'	A0500	69"	42"	2,263#
	20'	A0500	69"	42"	2,663#
1000#	4'	A1000	24"	12"	2,483#
	6'	A1000	27"	15"	3,489#
	8'	A1000	30"	18"	4,306#
	10'	A1000	33"	21"	4,987#
	12'	A1000	36"	24"	5,566#
	14'	A1000	39"	27"	6,066#
	16'	A1000	42"	30"	6,504#
	18'	A1000	46"	33"	6,892#
	20'	A1000	48"	36"	7,240#
2000#	4'	A2000	36"	12"	2,827#
	6'	A2000	42"	15"	4,053#
	8'	A2000	48"	18"	4,982#
	10'	A2000	54"	21"	5,713#
	12'	A2000	60"	24"	6,307#
	14'	A2000	66"	27"	6,800#
	16'	A2000	75"	30"	6,929#
	18'	A2000	111"	45"	5,325#

Chart 1A.

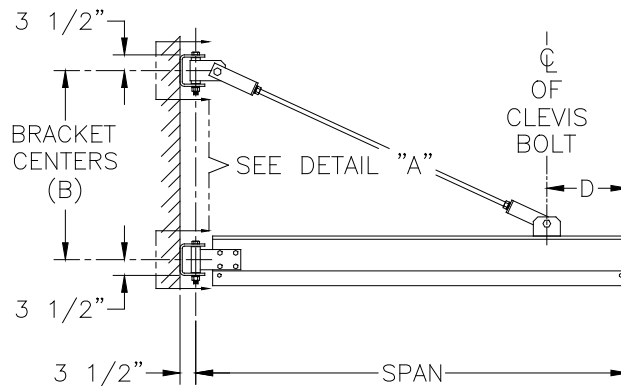

Diagram 1B.

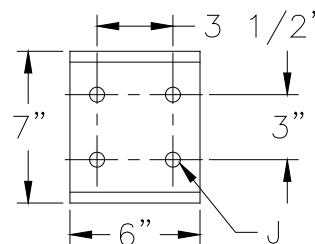

Diagram 1C. Detail "A"

	J
Hole Dia,	11/16"
Bolt Dia,	5/8"

Chart 1B

ALL DIMENSIONS ARE IN INCHES
HARDWARE FOR DETAIL "A" BY OTHERS

STEP 2 - BOOM INSTALLATION

➔ **TIP:** Upper and lower formed channels are identical.

STOP !

Do not proceed if your support structure does not meet the requirements identified in Step 1.4, page 1.

2.1 Determine position of upper formed channel bracket on support structure. Drill bolt holes (see **chart 1B** and **diagram 1C**, page 2, for bolt diameter) and bolt to support structure.

2.2 Determine position of lower formed channel bracket by measuring distance between bracket centers (**chart 1A**, page 2); clamp bracket to support structure. Align brackets by dropping plumb bob (by others) through pivot holes and making sure string is centered in pivot holes (**diagram 2A**). Shim, if necessary, between mounting surface and formed channel brackets (shims by others).

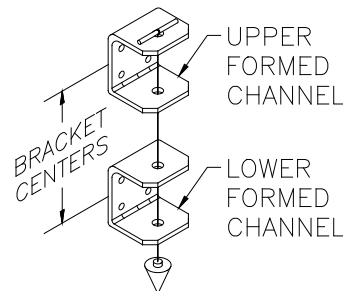

Diagram 2A. Plumbing formed channel brackets.

2.3 Drill bolt holes for **lower** bracket and bolt to support structure. Tighten all mounting bolts (by others; bolts should be grade 5 or better) to manufacturer's specifications.

2.4 Bolt lower pivot assembly to aluminum track web (using hardware provided) with a web spacer between the aluminum track and the lower pivot on both sides of the web (**diagram 2B**). Torque nuts (**chart 2A**).

Bolt Dia.	Torque
1/2"	50 ft.-lbs.
5/8"	95 ft.-lbs.
3/4"	175 ft.-lbs.
7/8"	300 ft.-lbs.
1"	450 ft.-lbs.

Chart 2A. Torque Ratings.

2.5 Bolt end of beam bracket to the top flange of the aluminum track (**diagram 2C**) using hardware provided. Torque nuts (**chart 2A**). Bolt formed clevis to end of beam bracket. Tighten nylock nut, **but do not torque**. Be sure formed clevis pivots freely.

2.6 Bolt tie rod to end of beam formed clevis (**diagram 2C**) using hardware provided. Torque nuts (**chart 2A**).

Note: Tie rod is right hand threaded at each end.

2.7 Bolt formed clevis to opposite end of tie rod (**diagram 2D**) using hardware provided. Torque nuts (**chart 2A**). Bolt formed clevis to upper pivot assembly. Tighten nylock nut, **but do not torque**. Be sure formed clevis pivots freely.

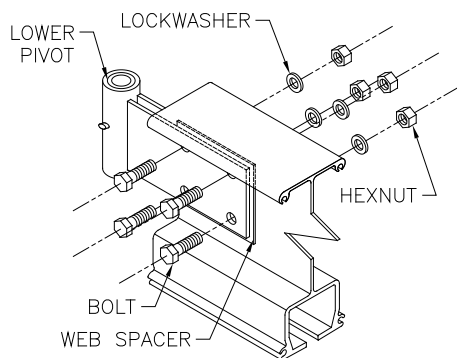

Diagram 2B. Bolting lower pivot assembly to boom.

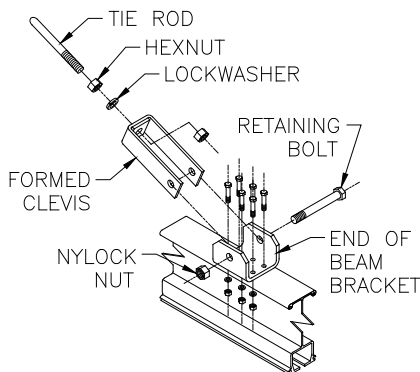

Diagram 2C. Bolting end of beam bracket to boom.

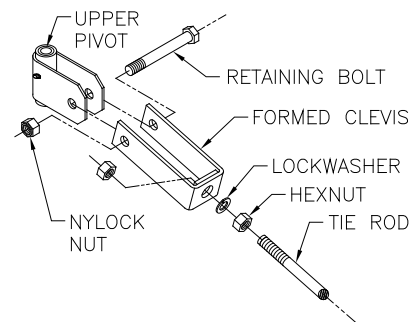

Diagram 2D. Attaching upper pivot assembly to tie rod.

STEP 2 - BOOM INSTALLATION (CONTINUED)

➔ **TIP:** Be sure bronze thrust washers are in place when attaching upper and lower pivots to upper and lower formed channels.

- 2.8** Lift boom assembly into place. Support boom assembly at all times until step 2.11 is complete.
- 2.9** Attach lower pivot assembly to lower formed channel using hardware provided (**diagram 2E**). Be sure that the thrust washer is in position. Tighten nut on pivot bolt until lockwasher is compressed.
- 2.10** Attach upper pivot assembly to upper formed channel using hardware provided (**diagram 2F**). Be sure that the thrust washer is in position. Tighten nut on pivot bolt until lockwasher is compressed.
- 2.11** Level boom to a point of 1/900 of span above level (for example, the end of the boom on a 10 ft. span would be .133" higher than the pivot end). Level by reducing distance between clevis assemblies along tie rod. Once boom is level, be sure to tighten nuts on tie rod to the proper torque (**chart 2A**, page 3).
- 2.12** Carefully swing boom through entire travel to ensure boom is clear of obstructions, rotates freely, and does not drift.

If boom does not rotate freely, slightly loosen the nuts on the pivot bolts until it does.

If boom drifts, check to make sure boom is properly leveled, pivots are plumb, and that the support structure is adequate.

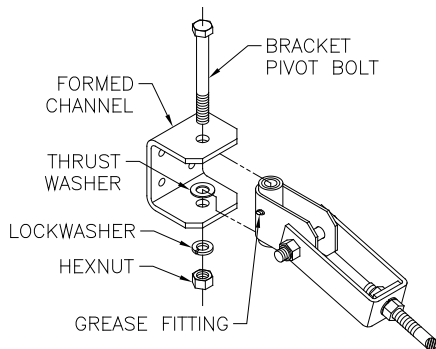

Diagram 2F. Attaching upper pivot assembly to upper formed channel.

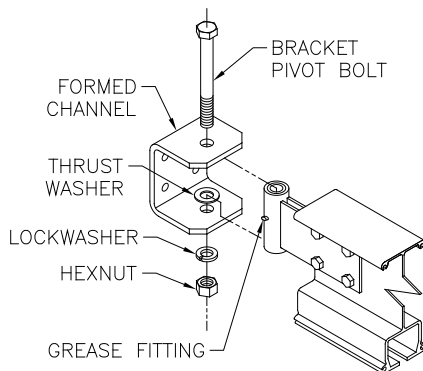

Diagram 2E. Attaching lower pivot assembly to lower formed channel.

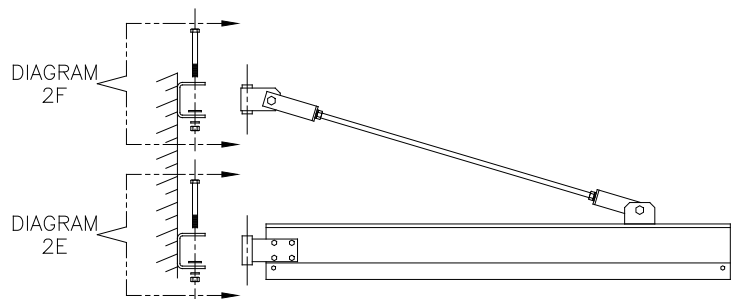

Diagram 2G. Attaching aluminum jib to formed channels.

STEP 3 - HOIST TROLLEY INSTALLATION

TIP: If you have festooning, festoon trolleys must be installed before hoist trolley.

3.1 Clean inside flanges of track with a clean, dry cloth (**do not use any kind of cleaning solution**) to remove grit or debris that may have collected during shipping, storage, or installation.

3.2 Install an endstop in the end of the track closest to the lower pivot (**diagram 3A**).

3.3 If you have festooning (optional), slide festoon clamp (optional) into track and bolt into place (**diagram 3B**); roll festoon trolleys through open end of track.

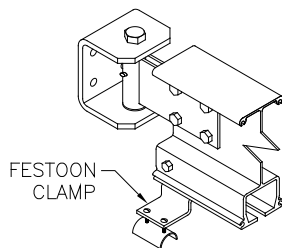

Diagram 3B. Festoon clamp.

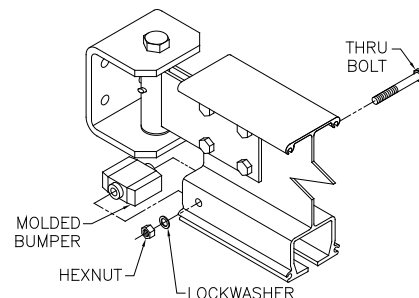
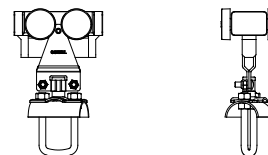

Diagram 3A. Endstop installation.



Festoon trolleys.

3.4 Attach hoist (by others) to hoist trolley by snapping the hoist suspension hook over the clevis pin of the hoist trolley.

If hoist suspension hook is too large or hoist has a suspension device other than a hook, you will need to remove the trolley clevis pin to install the suspension device (**diagrams 3C, 3D, 3E or 3F**).

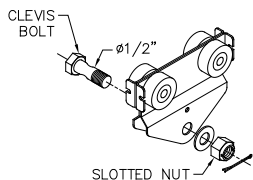

Diagram 3C. Installing hoist on A150 hoist trolley.

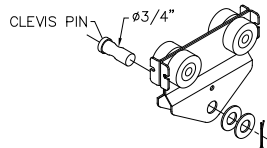

Diagram 3D. Installing hoist on A250-A500 hoist trolley.

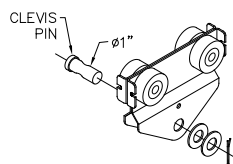

Diagram 3E. Installing hoist on A1000 hoist trolley.

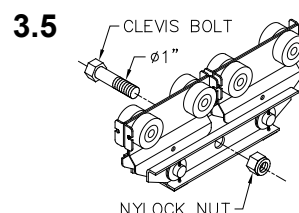

Diagram 3F. Installing hoist on A2000 hoist trolley.

Slide washers on clevis pin and insert cotter pin through trolley saddle clevis pin. Bend **both legs** of cotter pins (**diagram 3G**).

WARNING

Be sure that the legs of all cotter pins are bent (**diagram 3G**). If cotter pin is cracked or fatigued it must be replaced.

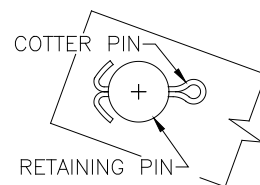

Diagram 3G. Installing cotter pin through trolley clevis pin.

3.6 Roll hoist trolley into open end of track.

3.7 Install endstop (**diagram 3H**).

3.8 Once all trolleys and end stops are installed, confirm that the trolleys contact the end stops appropriately and are not at risk of rolling past the stops.

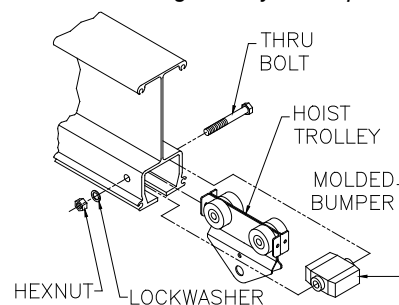

Diagram 3H. Installing hoist trolley and endstop.

STEP 4 - FESTOONING INSTALLATION

4.1 Installing Festoon Electric Cable/Air Hose/Vacuum Hose:

Festoon trolleys are designed to accept 4-conductor, electric flat or round cable (#10, #12, or #14 gauge) or air hose (7/8" maximum outside diameter).

WARNING

Crane cannot be utilized as a ground: 4-conductor cable **must** be used.

Electric Cable/Air Hose with Festoon Trolleys

Loosen nuts and clamp-plate enough to thread electric cable/air hose between the U-bolt legs and clamp plate on festoon trolley. Secure electric cable by tightening nuts on festoon trolley, forcing clamp plate snug against electric cable/air hose (**diagram 4A**).

Note: Be careful not to over tighten hardware; this will cause damage to electric cable/air hose.

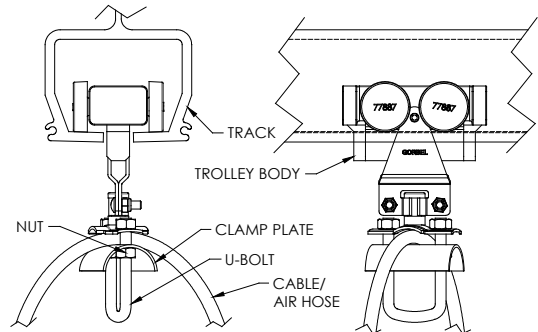

Diagram 4A. Installing electric cable or air hose on festoon trolley.

Vacuum Hose Trolleys

Place strap around vacuum hose (by others). Secure Velcro sides together and be sure vacuum hose is held snugly in place (**diagram 4B**). (Strap will fit vacuum hoses with outside diameters ranging from 1.5" - 2.5")

Clip vacuum hose hook (with vacuum hose attached) onto vacuum hose trolley (**diagram 4B**).

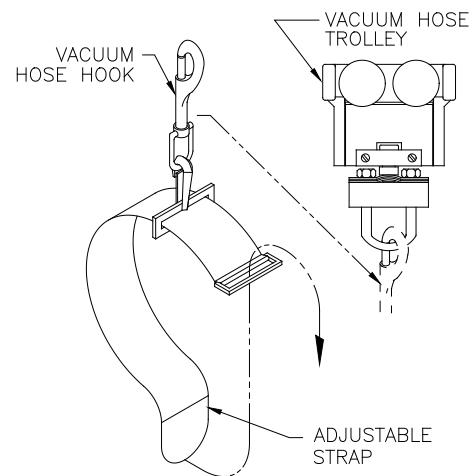

Diagram 4B. Installing vacuum hose on vacuum hose trolley.

STEP 5 - ACCESSORIES (OPTIONAL)

Other Options (Consult Gorbel® Representative)

- Positional Lock Devices

STEP 6 - FINAL STEPS

➡ **TIP:** Do not throw away this manual: maintenance schedule is on the back cover.

- 6.1** Check to make sure all bolts are tight, nuts are properly torqued, and lockwashers are compressed.
- 6.2** Grease all fittings (use Lubriplate #630-AA or equivalent).
- 6.3** If necessary, touch up crane fittings with paint provided.
- 6.4** Keep Packing List, Installation Manual, General Arrangement Drawing, and any other inserts filed together in safe place.

CRANE OPERATOR INSTRUCTIONS

Overhead cranes and jib cranes generally handle materials over working areas where there are personnel. Therefore, it is important for the Crane Operator to be instructed in the use of the crane and to understand the severe consequences of careless operation.

It is not intended that these suggestions take precedence over existing plant safety rules and regulations or OSHA regulations. However, a thorough study of the following information should provide a better understanding of safe operation and afford a greater margin of safety for people and machinery on the plant floor.

It must be recognized that these are suggestions for the Crane Operator's use. It is the responsibility of the owner to make personnel aware of all federal, state and local rules and codes, and to make certain operators are properly trained.

Qualifications

Crane operation, to be safe and efficient, requires skill: the exercise of extreme care and good judgment, alertness and concentration, and rigid adherence to proven safety rules and practices as outlined in applicable and current ANSI and OSHA safety standards. In general practice, no person should be permitted to operate a crane:

- Who cannot speak the appropriate language or read and understand the printed instructions.
- Who is not of legal age to operate this type of equipment.
- Whose hearing or eyesight is impaired (unless suitably corrected with good depth perception).
- Who may be suffering from heart or other ailments which might interfere with the operator's safe performance.
- Unless the operator has carefully read and studied this operation manual.
- Unless the operator has been properly instructed.
- Unless the operator has demonstrated his instructions through practical operation.
- Unless the operator is familiar with hitching equipment and practices.

Handling the Jib Boom Motion

Before using the boom of the jib crane, the operator should be sure the hook is high enough to clear any obstruction. Before a load is handled by the crane, the jib boom should be brought into position so that it is directly over the load. Start the jib boom slowly and bring it up to speed gradually. Approaching the place where it is desired to stop the jib, reduce the boom speed.

Handling the Trolley Motion

Before a load is handled, the hoist should be positioned directly over the load that is to be handled. When the slack is taken out of the slings, if the hoist is not directly over the load, bring it directly over the load before hoisting is continued. Failure to center the hoist over the load may cause the load to swing upon lifting. Always start the trolley motion slowly and reduce the trolley speed gradually.

Handling the Hoist Motion

Refer to the lifting (hoist) equipment's operating instructions.

GENERAL SUGGESTIONS

Know Your Crane

Crane operators should be familiar with the principal parts of a crane and have a thorough knowledge of crane control functions and movements. The crane operator should be required to know the location and proper operation of the main conductor disconnecting means for all power to the attachments on the crane.

Responsibility

Each crane operator should be held directly responsible for the safe operation of the crane. Whenever there is any doubt as to SAFETY, the crane operation should stop the crane and refuse to handle loads until: (1) safety has been assured or (2) the operator has been ordered to proceed by the supervisor, who then assumes all responsibility for the SAFETY of the lift.

Do not permit **ANYONE** to ride on the hook or a load.

Inspection

Test the crane movement and any attachments on the crane at the beginning of each shift. Whenever the operator finds anything wrong or apparently wrong, the problem should be reported immediately to the proper supervisor and appropriate corrective action taken.

Operating Suggestions

One measure of a good crane operator is the smoothness of the crane operation. The good crane operator should know and follow these proven suggestions for safe, efficient crane handling.

1. The crane should be moved smoothly and gradually to avoid abrupt, jerky movements of the load. Slack must be removed from the sling and hoisting ropes before the load is lifted.
2. Center the crane over the load before starting the hoist to avoid swinging the load as the lift is started. Loads should not be swung by the crane to reach areas not under the crane.
3. Crane-hoisting ropes should be kept vertical. Cranes shall not be used for side pulls.
4. Be sure everyone in the immediate area is clear of the load and aware that a load is being moved.
5. Do not make lifts beyond the rated load capacity of the crane, sling chains, rope slings, etc.
6. Make certain that before moving the load, load slings, load chains, or other lifting devices are fully seated in the saddle of the hook with hook latch closed (if equipped with hook latch).
7. Check to be sure that the load and/or bottom block is lifted high enough to clear all obstructions when moving boom or trolley.
8. At no time should a load be left suspended from the crane unless the operator has the push button with the power on, and under this condition keep the load as close as possible to the floor to minimize the possibility of an injury if the load should drop. When the crane is holding a load, the crane operator should remain at the push button.
9. Do not lift loads with sling hooks hanging loose. If all sling hooks are not needed, they should be properly stored, or use a different sling.
10. All slings or cables should be removed from the crane hooks when not in use (dangling cables or hooks hung in sling rings can inadvertently snag other objects when the crane is moving).
11. Operators shall not carry loads and/or empty bottom blocks over personnel. Particular additional caution should be practiced when using magnet or vacuum devices. Loads, or parts of loads, held magnetically could drop. Failure of power to magnets or vacuum devices can result in dropping the load. Extra precaution should be exercised when handling molten metal in the proximity of personnel.
12. Whenever the operator leaves the crane the following procedure should be followed:
 - Raise all hooks to an intermediate position.
 - Spot the crane at an approved designated location.
 - Place all controls in the "off" position.
 - Open the main switch to the "off" position.
 - Make visual check before leaving the crane.
13. In case of emergency or during inspection, repairing, cleaning or lubrication, a warning sign or signal should be displayed and the main switch should be locked in the "off" position. This should be done whether the work is being done by the crane operator or by others.
14. Contact with rotation stops or trolley end stops shall be made with extreme caution. The operator should do so with particular care for the safety of persons below the crane, and only after making certain that any persons on the other cranes are aware of what is being done.
15. **ANY SAFETY FEATURES AND MECHANISMS BUILT IN OR OTHERWISE PROVIDED WITH THE CRANE BY GORBEL ARE REQUIRED FOR THE SAFE OPERATION OF THE CRANE. DO NOT, UNDER ANY CIRCUMSTANCES, REMOVE OR OTHERWISE IMPAIR OR DISABLE THE PROPER FUNCTIONING OF ANY CRANE SAFETY MECHANISMS OR FEATURES BUILT-IN OR OTHERWISE PROVIDED BY GORBEL FOR SAFE OPERATION OF THE CRANE. ANY REMOVAL, IMPAIRMENT OR DISABLING OF ANY SUCH SAFETY MECHANISMS OR FEATURES OR OTHER USE OR OPERATION OF THE CRANE WITHOUT THE COMPLETE AND PROPER FUNCTIONING OF ANY SUCH SAFETY MECHANISMS OR FEATURES AUTOMATICALLY AND IMMEDIATELY VOIDS ANY AND ALL EXPRESS AND IMPLIED WARRANTIES OR ANY KIND OR NATURE.**

LIMITED WARRANTY

It is agreed that the equipment purchased hereunder is subject to the following LIMITED warranty and no other. Gorbel Incorporated ("Gorbel") warrants the manual push-pull Work Station Cranes, Jib Crane, and Gantry Crane products to be free from defects in material or workmanship for a period of ten years or 20,000 hours use from date of shipment. Gorbel warrants the Motorized Work Station Cranes and Jib Crane products to be free from defects in material or workmanship for a period of two years or 4,000 hours use from the date of shipment. Gorbel warrants the G-Force® and Easy Arm™ products to be free from defects in material or workmanship for a period of one year or 2,000 hours use from the date of shipment. This warranty does not cover Gantry Crane wheels. This warranty shall not cover failure or defective operation caused by operation in excess of recommended capacities, misuses, negligence or accident, and alteration or repair not authorized by Gorbel. No system shall be field modified after manufacture without the written authorization of Gorbel, Inc. Any field modification made to the system without the written authorization of Gorbel, Inc. shall void Gorbel's warranty obligation. OTHER THAN AS SET FORTH HEREIN, NO OTHER EXPRESS WARRANTIES, AND NO IMPLIED WARRANTIES, ORAL OR WRITTEN, INCLUDING BUT NOT LIMITED TO THE WARRANTIES OF MERCHANTABILITY OR FITNESS FOR A PARTICULAR PURPOSE, ARE MADE BY GORBEL WITH RESPECT TO ITS PRODUCTS AND ALL SUCH WARRANTIES ARE HEREBY SPECIFICALLY DISCLAIMED. GORBEL SHALL NOT BE LIABLE UNDER ANY CIRCUMSTANCES FOR ANY INCIDENTAL, SPECIAL AND/OR CONSEQUENTIAL DAMAGES WHATSOEVER, WHETHER OR NOT FORESEEABLE, INCLUDING BUT NOT LIMITED TO DAMAGES FOR LOST PROFITS AND ALL SUCH INCIDENTAL, SPECIAL AND/OR CONSEQUENTIAL DAMAGES ARE HEREBY ALSO SPECIFICALLY DISCLAIMED. Gorbel's obligation and Purchaser's or end user's sole remedy under this warranty is limited to the replacement or repair of Gorbel's products at the factory, or at the discretion of Gorbel, at a location designated by Gorbel. Purchaser or end user shall be solely responsible for all freight and transportation costs incurred in connection with any warranty work provided by Gorbel hereunder. Gorbel will not be liable for any loss, injury or damage to persons or property, nor for damages of any kind resulting from failure or defective operation of any materials or equipment furnished hereunder. Components and accessories not manufactured by Gorbel are not included in this warranty. Purchaser's or end user's remedy for components and accessories not manufactured by Gorbel is limited to and determined by the terms and conditions of the warranty provided by the respective manufacturers of such components and accessories.

A) DISCLAIMER OF IMPLIED WARRANTY OF MERCHANTABILITY

Gorbel and Purchaser agree that the implied warranty of merchantability is excluded from this transaction and shall not apply to the goods involved in this transaction.

B) DISCLAIMER OF IMPLIED WARRANTY OF FITNESS FOR PARTICULAR PURPOSE

Gorbel and Purchaser agree that the implied warranty of fitness for particular purpose is excluded from this transaction and shall not apply to the goods involved in this transaction.

C) DISCLAIMER OF EXPRESS WARRANTY

Gorbel's agents, or dealer's agents, or distributor's agents may have made oral statements about the machinery and equipment described in this transaction. Such statements do not constitute warranties, and Purchaser agrees not to rely on such statements. Purchaser also agrees that such statements are not part of this transaction.

D) DISCLAIMER OF SPECIAL, INCIDENTAL AND CONSEQUENTIAL DAMAGES

Gorbel and Purchaser agree that any claim made by Purchaser which is inconsistent with Gorbel's obligations and the warranty remedies provided with Gorbel's products, and in particular, special, incidental and consequential damages, are expressly excluded.

E) DEALER OR DISTRIBUTOR NOT AN AGENT

Gorbel and Purchaser agree that Purchaser has been put on notice that dealer or distributor is not Gorbel's agent in any respect for any reason. Gorbel and Purchaser also agree that Purchaser has been put on notice that dealer or distributor is not authorized to incur any obligations or to make any representations or warranties on Gorbel's behalf other than those specifically set forth in Gorbel's warranty provided in connection with its product.

F) MERGER

This warranty agreement constitutes a final and complete written expression of all the terms and conditions of this warranty and is a complete and exclusive statement of those terms.

G) PAINTING

Every crane (excluding components) receives a quality paint job before leaving the factory. Unfortunately, no paint will protect against the abuses received during the transportation process via common carrier. We have included at least one (1) twelve ounce spray can for touchup with each crane ordered (unless special paint was specified). If additional paint is required, contact a Gorbel® Customer Service Representative at 1-800-821-0086 or 1-585-924-6262.

Title and Ownership:

Title to the machinery and equipment described in the foregoing proposal shall remain with Gorbel and shall not pass to the Purchaser until the full amount herein agreed to be paid has been fully paid in cash.

Claims and Damages:

Unless expressly stated in writing, goods and equipment shall be at Purchaser's risk on and after Seller's delivery in good shipping order to the Carrier. Gorbel shall in no event be held responsible for materials furnished or work performed by any person other than it or its authorized representative or agent.

Cancellations:

If it becomes necessary for the purchaser to cancel this order wholly or in part, he shall at once so advise Gorbel in writing. Upon receipt of such written notice all work will stop immediately. If the order entails only stock items, a flat restocking charge of 15% of the purchase price will become due and payable by Purchaser to Gorbel. Items purchased specifically for the canceled order shall be charged for in accordance with the cancellation charges of our supplier plus 15% for handling in our factory. The cost of material and/or labor expended in general fabrication for the order shall be charged for on the basis of total costs to Gorbel up to the time of cancellation plus 15%.

Returns:

No equipment, materials or parts may be returned to Gorbel without express permission in writing to do so.

Extra Charge Delay: If Purchaser delays or interrupts progress of Seller's performance, or causes changes to be made, Purchaser agrees to reimburse Gorbel for expense, if any, incident to such delay.

Changes and Alterations:

Gorbel reserves the right to make changes in the details of construction of the equipment, as in its judgment, will be in the interest of the Purchaser; will make any changes in or additions to the equipment which may be agreed upon in writing by the Purchaser; and Gorbel is not obligated to make such changes in products previously sold any customer.

Third Party Action:

Should Gorbel have to resort to third party action to collect any amount due after thirty (30) days from date of invoice, the Purchaser agrees to pay collection costs, reasonable attorney's fees, court costs and legal interest.

OSHA Responsibilities:

Gorbel agrees to fully cooperate with Purchaser in the design, manufacture or procurement of safety features or devices that comply with OSHA regulations. In the event additional equipment or labor shall be furnished by Gorbel, it will be at prices and standard rates then in effect, or as may be mutually agreed upon at the time of the additional installation.

Equal Employment Opportunity:

Gorbel agrees to take affirmative action to ensure equal employment opportunity for all job applicants and employees without regard to race, color, age, religion, sex, national origin, handicap, veteran, or marital status. Gorbel agrees to maintain non-segregated work facilities and comply with rules and regulations of the Secretary of Labor or as otherwise provided by law or Executive Order.

INSPECTION AND MAINTENANCE

GORBEL® WALL BRACKET JIB CRANE INSPECTION AND MAINTENANCE SCHEDULE			
ITEM	COMPONENT	MAINTENANCE	FREQUENCY*
1	Mounting Bolts	Check that lockwashers are compressed and nuts are tightened to manufacturer's specifications.	Every 500 hours or 3 months
2	Upper Pivot Assembly	Check that lockwashers are compressed. Check for wear on thrust washer. Grease fitting (use Lubriplate #630-AA or equivalent).	Every 1000 hours or 6 months
3	Lower Pivot Assembly	Check that lockwashers are compressed. Check for wear on thrust washer. Grease fitting (use Lubriplate #630-AA or equivalent). Check that nuts on bolts through aluminum web are tightened to torque specifications (chart 2A, page 3).	Every 1000 hours or 6 months
4	End of Beam Bracket	Check that lockwashers are compressed and nuts are tightened to torque specifications (chart 2A, page 3).	Every 1000 hours or 6 months
5	End Stops	Check that lockwashers are compressed. If through-bolt is exposed, replace end stops.	Every 500 hours or 3 months
6	Hoist Trolley	Check clevis pin for wear. Check cotter pint. (Cotter pin should be fully wrapped around clevis pin.)	Every 1000 hours or 6 months
7	Wheels (hoist trolley)	Check wheels for cracks, pits, and/or grooves: all of these increase pull forces. If any of these conditions exist, wheels should be replaced.	Every 1000 hours or 6 months
8	Accessory Items	Conduct a general inspection of all accessory items.	Every 1000 hours or 6 months
9	Gorbel® Crane	Conduct a visual inspection of wall bracket jib crane.	Every 1000 hours or 6 months

*Federal, state and local codes may require inspection and maintenance checks more often. Please check the federal, state and local code manuals in your area.

WARNING

Any changes in rolling effort or unusual noises must be immediately identified and corrected. It is not necessary to lubricate the track or bearings. Lubricating may attract airborne particles and may increase the rolling resistance. Do not use such substances as WD40, silicone sprays, oil or grease.

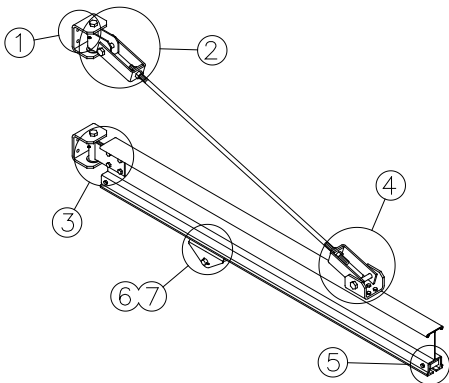

WARNING

This product contains chemicals known to the State of California to cause cancer and birth defects or other reproductive harm.

For more information: www.P65Warnings.ca.gov

GORBEL®
A CLASS ABOVE

600 Fishers Run, P.O. Box 593
Fishers, NY 14453-0593
Phone: (800) 821-0086
Fax: (800) 828-1808
E-Mail: info@gorbel.com
<http://www.gorbel.com>
© 2026 Gorbel, Inc.
All Rights Reserved

