

Free Standing Motorized Jib Crane

Installation, Operation & Maintenance Manual

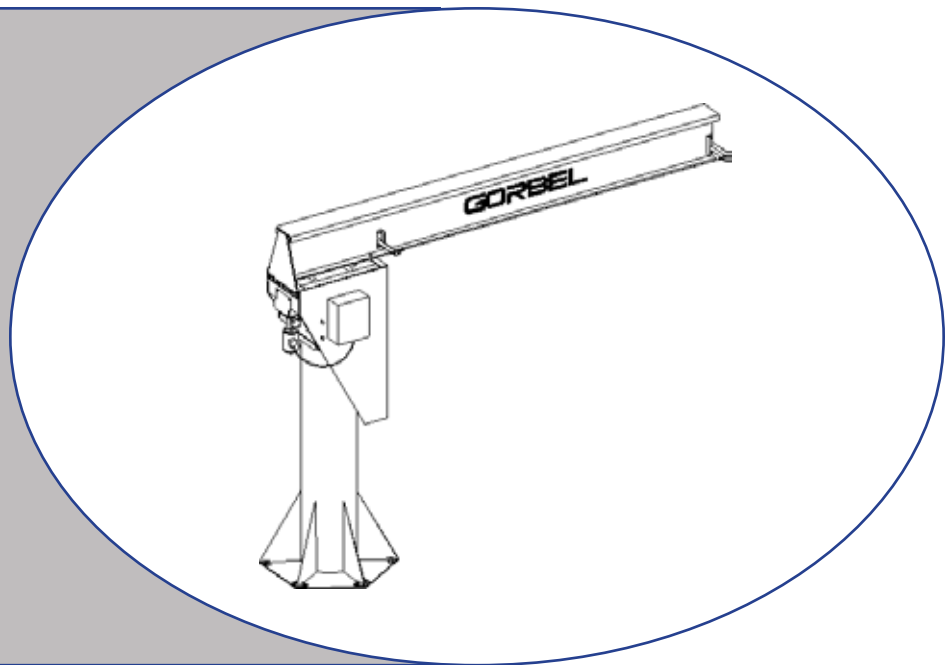

Part Number: MAN-US044-R02 Released 3/2026
Find manual updates at:
<https://www.gorbel.com/service-support/archived-installation-manuals>



Scan to Register
Your Warranty

Gorbel[®] Customer Order No. / Serial No.

Gorbel[®] Dealer

Table of Contents

Introduction	1
Installation.....	2
Step 1 - Pre-Assembly.....	2
Step 2 - Mast Installation	3
Step 3 - Head Installation.....	5
Step 4 - Boom Installation	6
Step 5 - Drive Installation.....	7
Step 6 - Electrification Installation.....	9
Step 7 - Final Steps	13
Shut-Down Instructions.....	13
Safety Warning and Precautions.....	13
Troubleshooting Guide.....	14
Hardware Torque Chart	14
Spare Parts List (Call Gorbel® Dealer to order)	15
Appendix A: Securex Friction Torque Limiter Type C & T	16
Crane Operator Instructions	20
Limited Warranty.....	21
Maintenance Schedule	22
Lubrication Schedule	22

 WARNING

This product contains chemicals known to the State of California to cause cancer and birth defects or other reproductive harm.

For more information: www.P65Warnings.ca.gov

©2026 Gorbel Inc.,
All Rights Reserved.

600 Fishers Run, P.O. Box 593
Fishers, NY 14453-0593
Telephone: (800) 821-0086
(585) 924-6262
Fax: (800) 828-1808

Introduction

Thank you for choosing a Gorbel® Free Standing Jib Crane to solve your material handling needs. The innovative design and heavy-duty construction of the Gorbel® Free Standing Jib Crane will provide a superior quality product that will offer years of long term value. All Gorbel® cranes are pre-engineered for powered hoist operation. The hoist weight allowance is 15% of the crane capacity (for example, a crane rated for 1000 pounds allows for 1000 pounds live load plus 150 pounds for the weight of the hoist). There is also an allowance of 25% of the crane capacity for impact caused by hoist use. Gorbel® Free Standing Jib Cranes will provide many years of dependable service by following the installation and maintenance procedures described herein.

Dimensions contained in this installation manual are for reference only and may differ for your particular application. Please refer to the enclosed General Arrangement Drawing for actual dimensions.

Normal safety precautions: These include, but are not limited to:

- Checking for all obstructions in crane rotation
- Checking that all bolts are tight and have lockwashers
- Making sure that endstop is in place
- Making sure that festooning cannot be snagged or pinched

For additional safety precautions, see page 13.



WARNING: Only competent erection personnel familiar with standard fabrication practices should be employed to assemble these cranes because of the necessity of properly interpreting these instructions. Gorbel is not responsible for the quality of workmanship employed in the installation of a crane according to these instructions. Contact Gorbel, Inc., at 600 Fishers Run, P.O. Box 593, Fishers, New York 14453-0593, 1-585-924-6262, for any additional information if necessary.



WARNING: Equipment described herein is not designed for, and should not be used for, lifting, supporting or transporting humans. Failure to comply with any one of the limitations noted herein can result in serious bodily injury and/or property damage. Check State and Local regulations for additional requirements.



WARNING: Consult a qualified structural engineer to determine if your support structure is adequate to support the loads generated by anchor bolt force, overturning moment, or axial load of your crane.



WARNING: Crane cannot be utilized as a ground: A separate ground wire is required. For example, systems with 3-phase power require 3 conductors plus one ground wire.



WARNING: Reference American Institute of Steel Construction (AISC) manual of Steel Construction (9th edition), Part 5, Specification for Structural Joints using ASTM A325 or A490 Bolts (section 8.d.2) for proper procedures to follow when using any torque tightening method.



WARNING: Do not field modify crane in any way. Any modifications without the written consent of Gorbel, Inc. will void warranty.



WARNING: Unless otherwise specifically stated, Gorbel® parts and products are designed for indoor use. Storing and/or using your items outside (even if covered), exposed to the elements, or in any method other than intended, may void all or some of the product warranty. Always store Gorbel® parts and products indoors, in a cool and dry area.

Installation

Step 1 - Pre-Assembly

TIP: Packing list can be found in plastic pocket attached to hardware box. General Arrangement Drawing can be found inserted in this installation manual.

- 1.1 Read entire manual **before** installing the crane.
- 1.2 Check packing list to ensure no parts have been lost prior to initiating assembly of crane.
- 1.3 Tools and materials (by others) typically needed to assemble crane:

- Torque wrench
- Hand tools
- Allen wrenches
- Steel shims
- Base plate template
- Ladders / man lifts
- Open end wrench or Allen key for clutch
- Leveling tools (plumb bob, plumb fixture - page 4)
- Lifting device to lift heavy masts and booms
- Grout (non-shrink precision grout)
- Anchor bolts (by others, grade 5 or better)

STANDARD BOOM DATA		
Boom Height (W)	Beam Size	Flange Width (in)
6"	W6 @ 12#/ft.	4"
8"	W8 @ 18.4#/ft.	5-1/4"
10"	W10 @ 26#/ft.	5-3/4"
12"	W12 @ 35#/ft.	6-1/2"
16"	W16 @ 45#/ft.	7"
18"	W18 @ 50#/ft.	7-1/2"
21"	W21 @ 62#/ft.	8-1/4"
24"	W24 @ 84#/ft.	9"

Chart 1A. Boom data.

- 1.4 Identify crane type:



WARNING: Consult a qualified structural engineer to determine that your support structure is adequate to support the loads generated by anchor bolt force, overturning moment, or axial load of your crane.

If your crane looks like:

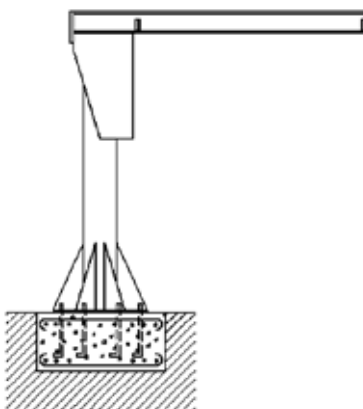

Go to Step 2.1

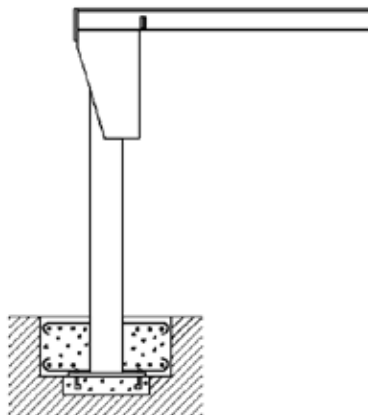

Go to Step 2.4

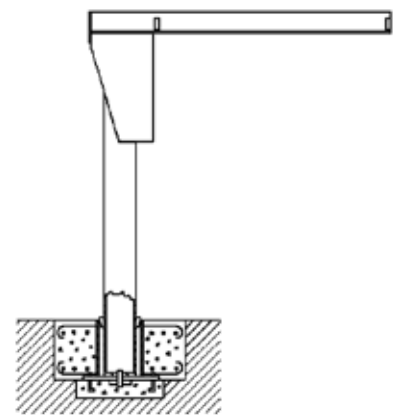

Go to Step 2.7

Step 2 - Mast Installation

FS300 Base Plate Mounted (diagram 2A)

- 2.1 Pour the footing, according to the dimensions on the General Arrangement Drawing, with the anchor bolts in place.
- 2.2 Once the concrete has set up, cover the baseplate area with one (1") inch of grout.
- 2.3 Set the mast in place and tighten the bolts until the base plate is completely seated in the grout and the mast is plumb per the plumbing procedure on page 4.

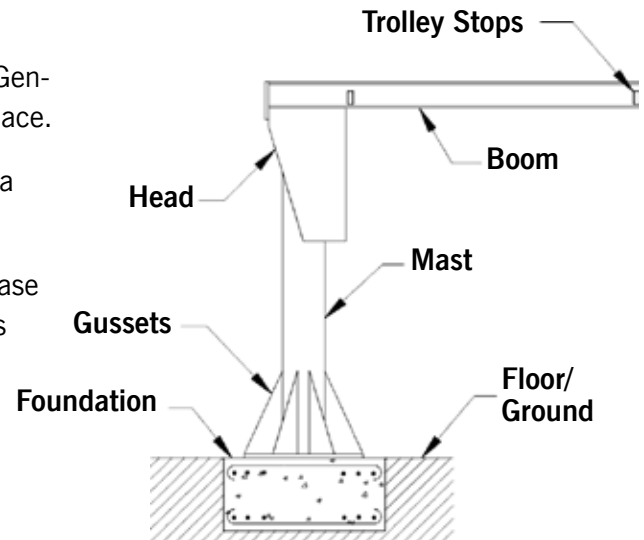

Diagram 2A. FS300 Base Plate Mounted.

FS350 Insert Mounted (diagram 2B)

- 2.4 Make the first pour with the anchor bolts in place.
- 2.5 Once the concrete has set up, set the mast in place and tighten the anchor bolts, making sure the mast is plumb per the plumbing procedure on page 4.
- 2.6 Make the second pour according to the footing dimensions on the General Arrangement Drawing.

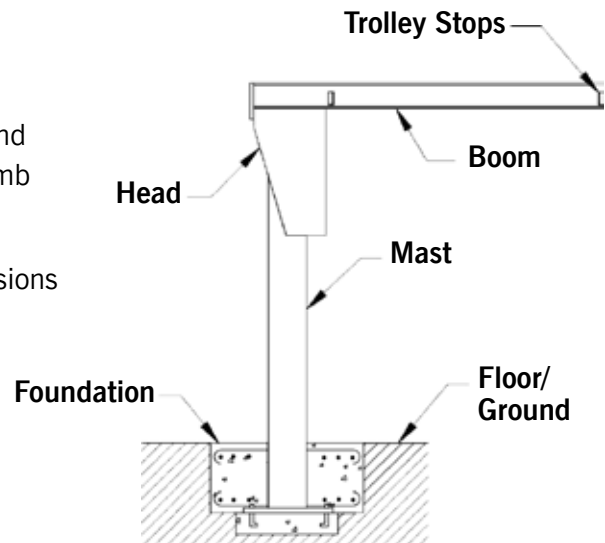

Diagram 2B. FS350 Insert Mounted.

FS350S Sleeve Insert Mounted (diagram 2C)

- 2.7 Make the first pour with the anchor bolts in place.
- 2.8 Once the concrete has set up, set the sleeve in place and tighten the anchor bolts, making sure the sleeve is plumb.
- 2.9 Make the second pour according to the footing dimensions on the General Arrangement Drawing.
- 2.10 When the second pour has set up, insert the mast inside the sleeve. Ensure the mast centering pin is fully inserted in the centering hole in the sleeve.
- 2.11 Using steel wedges (included) every 60°, plumb the mast per the plumbing procedure on page 4.
- 2.12 Once the mast is plumb, weld the steel wedges to the mast and sleeve to prevent any shifting of the mast. All welds to be per AWS D1.1.

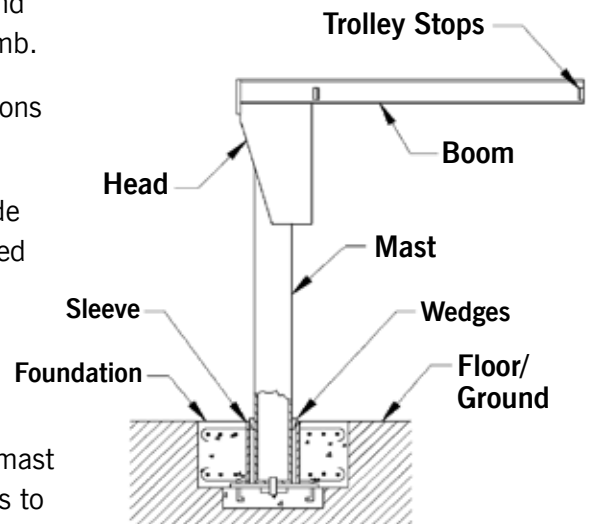

Diagram 2C. FS350S Sleeve Insert Mounted.

TIP: Be sure to fasten the plumb line secure to a plumb fixture (not included) so that it will not move. Movement will result in an inaccurate plumb measurement.

Plumbing Procedure

- 2.13 Drop a plumb line (not included) from the top of the mast, using the fixture (not included) or equivalent as shown in **diagram 2D**. **Do not use a level to plumb the mast.**
- 2.14 At point “A”, one (1”) inch below the mast top plate, set the plumb line at a distance of three (3”) inches from the surface of the mast pipe (**diagram 2E**).
- 2.15 At point “B”, five (5’) feet below point “A”, approximately where the trunnion rollers will contact the mast, the distance between the plumb line and the face of the mast should also be three (3”) inches. This is a plumb situation.
- 2.16 Repeat this every 60° to ensure the mast is plumb throughout.

Note: Be sure to fasten plumb line securely to plumb fixture so that it will not move. Movement will result in an inaccurate plumb measurement.

- 2.17 Once mast is plumb and grout (FS300) has cured, fully tighten anchor bolt hardware.
- 2.18 Verify mast is still plumb.

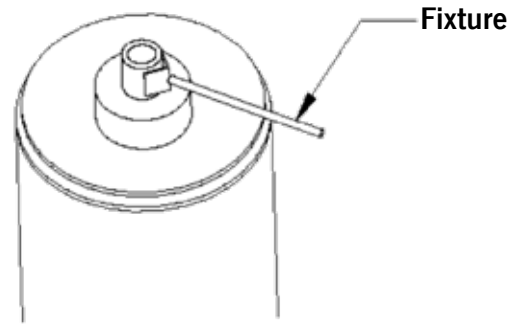

Diagram 2D. Plumbing fixture.

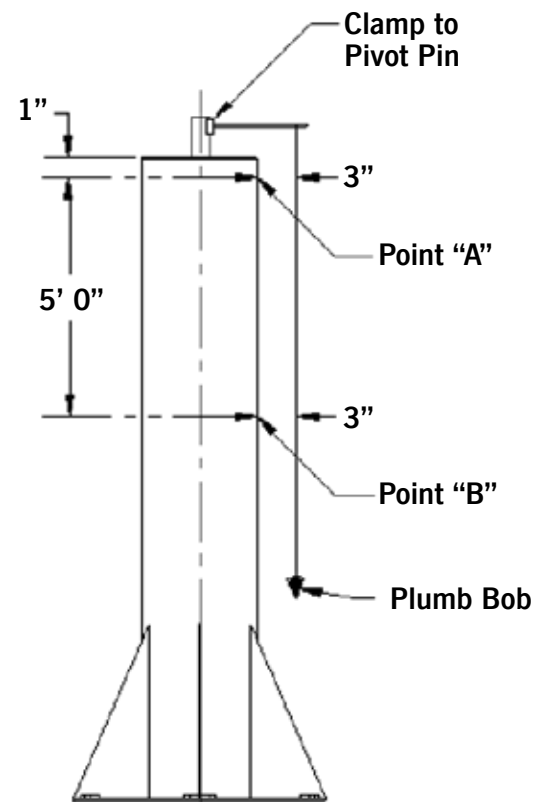

Diagram 2E. Plumbing the mast.

DO NOT USE A LEVEL TO PLUMB THE MAST

Step 3 - Head Installation

- 3.1 Wipe protective grease coating off and/or remove tape from pivot pin.
- 3.2 Place and orient tapered roller bearing inner race (cone) on the mast pivot pin (**diagram 3A**).
- 3.3 Remove safety channel from head assembly if it is bolted into place.
- 3.4 Place the head on the mast. Install V-ring seal (shipped loose) over mast pivot pin and press against weight bearing frame. Secure head by inserting the safety retaining pin into the hole located in the mast pivot pin. Ensure that the safety retaining pin is centered to within 1/16" inside of the mast pivot pin. Place two (2) hose clamps (one on either side) over each end of the safety retaining pin and slide them inward until they come in contact with the mast pivot pin (**diagram 3B**). Tighten both hose clamps such that the safety retaining pin is locked into place without the ability to slide sideways. Also ensure that both hose clamps are identically oriented on the pin, and once tightened, ensure the clamp screws are facing downward.

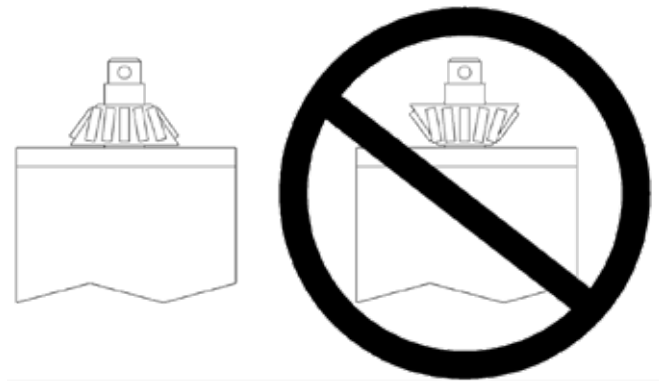

Diagram 3A. Bearing orientation

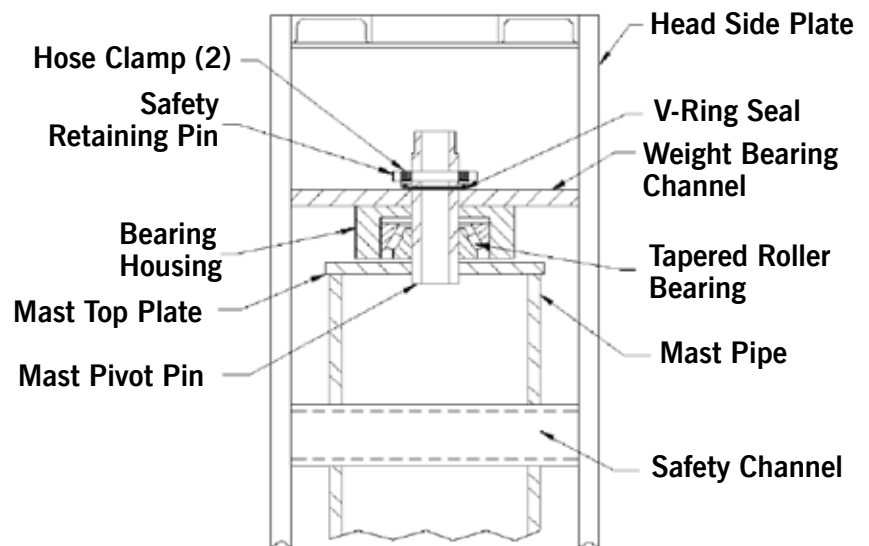

Diagram 3B. Head assembly installation

Note: It is imperative that the safety retaining pin is installed in the “centered” position to avoid a possible interference with the threaded stud welded to the weight bearing frame.

- 3.5 Reinstall the safety channel into the head if removed in Step 3.3.

Step 4 - Boom Installation

- 4.1 Set the boom on the head and attach to the head using the hardware provided. Two (2) bolts are required in the front (under boom mounting) and all holes in the back of boom plate require bolts (**diagram 4A**).
- 4.2 Adjust the boom to a point of $L/300$ (length of span in inches divided by 300) above level. Leveling is done by adding shims under the boom at the front of the head (when the pipe diameter is 14", 16", 18" or 20") or by evenly adjusting the hexnuts on the threaded rod on the trunnion roller assembly (when the pipe diameter is 24" or 30").
- 4.3 Torque the back of boom mounting hardware and the under boom hardware per the chart on page 14.

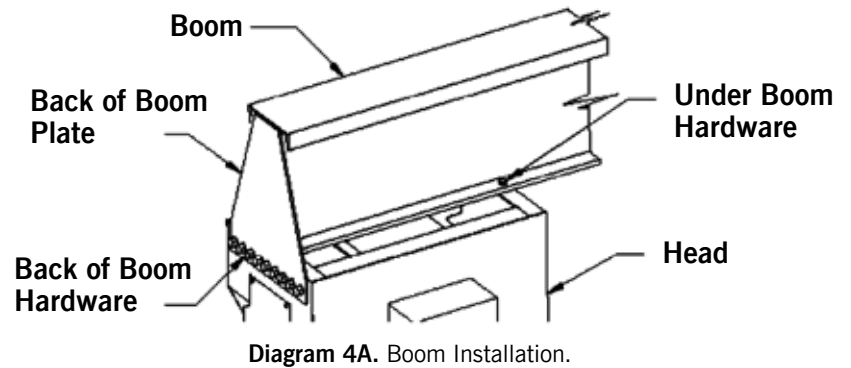

Step 5 - Drive Installation

TIP: Use caution to support the drive components during assembly and adjustment.

5.1 Remove the chain cover (**diagram 5A**).

5.2 The clutch is pre-tightened by Gorbel. If any additional clutch adjustment is required, refer to the friction clutch instructions on page 8. If the clutch is not tightened properly, the drive sprocket may slip and the crane may not rotate properly.

5.3 Back off the four (4) jacking screws to allow the drive assembly to move towards the mast.

5.4 Loosen the drive assembly mounting hardware allowing the drive mounting weldment to slide inside head.

5.5 Slide the drive assembly towards the mast. This minimizes the center distance between the drive and driven sprockets.

5.6 Ensure that the drive and driven sprockets are vertically level to each other. If they are not, then loosen the clutch mounting hardware, slide the clutch up or down until the sprockets are level, and re-tighten the hardware.

5.7 Install the chain around the drive and driven sprockets and use the connecting link to join the two ends of the chain.

5.8 Evenly adjust the four (4) jacking screws to tension the chain. Make sure the drive sprocket is parallel to the driven sprocket (not cocked). The chain should have 1/4" maximum total slack.

5.9 Tighten the drive weldment hardware. Torque per chart on page 14.

5.10 Reinstall the chain cover making sure it has adequate clearance to all of the moving drive components. Torque the mounting hardware per chart on page 14.

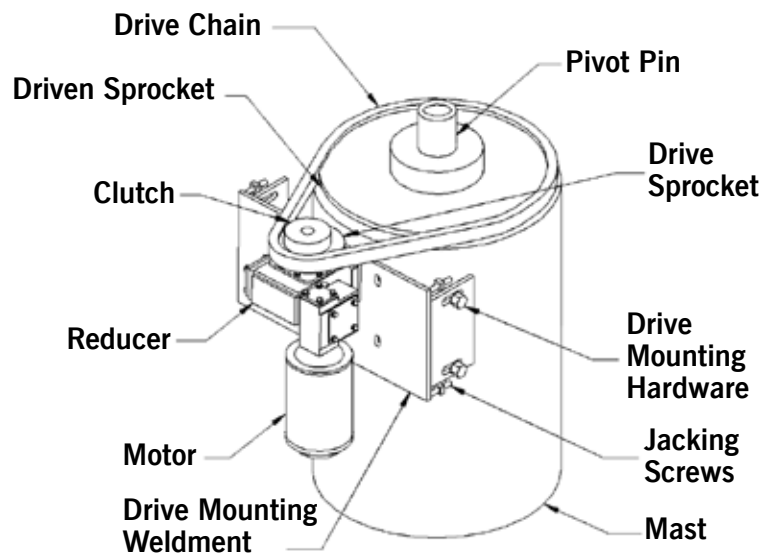

Diagram 5A. Drive assembly (head is not shown for clarity)



STOP! If your crane was purchased prior to 2021, refer to the instructions below. For cranes purchased since 2021, go to Appendix A on page 16.

TIP: The friction clutch is shipped **pre-tightened** by Gorbel. If the clutch begins to slip during initial use, **within the rated capacity of the crane**, allow the clutch to slip several times then re-tighten the clutch per the instructions below. The purpose for allowing the clutch to slip several times is to establish a uniform surface on the friction linings.

Friction Clutch

5.11 During normal operation, adjustment to compensate for friction lining wear may be necessary. The frequency of these adjustments will be dependent on the frequency of overloads occurring. The clutch torque adjustment method is dependent on the clutch type which is determined by whether the crane is used indoors (without a wind load) or outdoors (with a wind load).

Clutch Torque Adjustment - Cranes Used Indoors (diagram 5B)

Loosen the locking screw on the adjusting nut. Using the hook wrench provided, turn the adjusting nut counter-clockwise until the drive sprocket can turn freely in the clutch. The clutch can now be re-tightened to the proper torque setting. Turn the adjusting nut clockwise until it is hand tight. Using the hook wrench provided, tighten the adjusting nut an additional two full revolutions. After the adjustment is made, tighten the locking screw to ensure that the adjusting nut doesn't loosen. The proper torque setting is achieved when the drive sprocket will not slip under normal operating procedures.

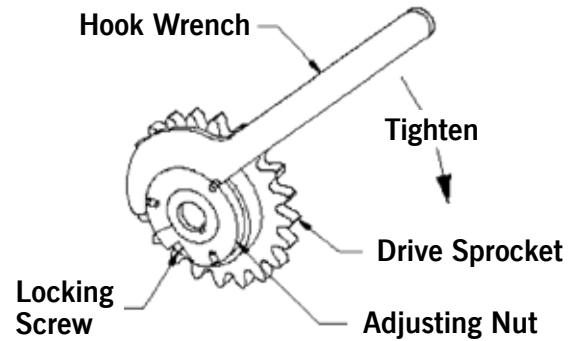

Diagram 5B. Indoor Clutch Torque Adjustment.

Clutch Torque Adjustment - Cranes Used Outdoors (diagram 5C)

Back off the disc spring set screws. Turn the adjusting nut clockwise until the disc spring stacks touch the control element. Re-tighten all disc spring set screws until they are flush with the adjusting nut. The proper torque setting is achieved when the drive sprocket will not slip under normal operating conditions.

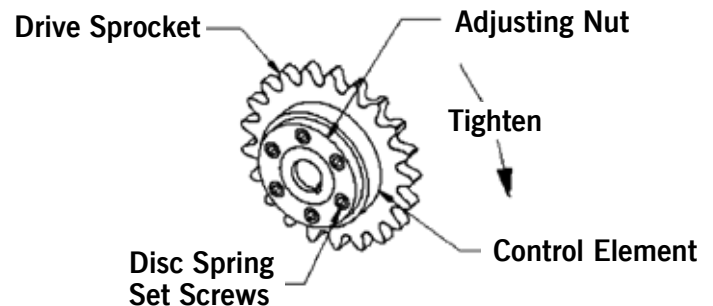

Diagram 5C. Outdoor Clutch Torque Adjustment.

Step 6 - Electrification Installation

Bottom Entry Collector Installation (diagram 6A)

- A. Remove the collector cover, the safety retaining pin and o-rings (2).
- B. Install the collector adapter pin if applicable (positioned inside of the mast pivot pin).
- C. Secure with the safety retaining pin and o-rings (2).
- D. Place the bottom entry collector on top of the adapter pin and secure with the set screws.
- E. Terminate the incoming power wires coming up through the mast inside the collector.
- F. Terminate the outgoing power wires to the control panel.
- G. Re-install the collector cover.

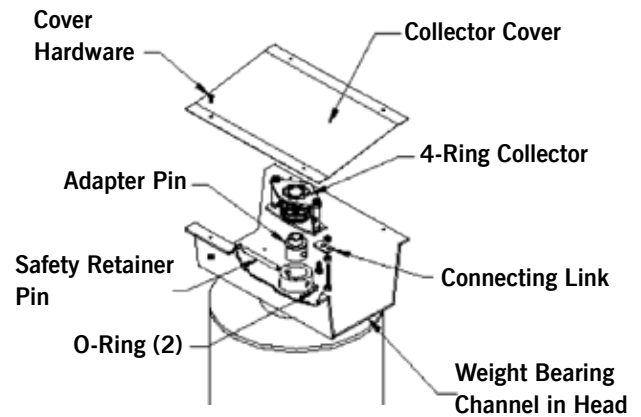

Diagram 6A. Bottom entry collector

Top Entry Collector Installation (diagram 6B)

- A. Position the collector over the mounting hole pattern on top of the boom cap channel (or mounting plate for booms without a cap channel).
- B. Secure with the mounting hardware provided.
- C. Terminate the incoming power wires from the power source.
- D. Terminate the outgoing power wires from the control panel.

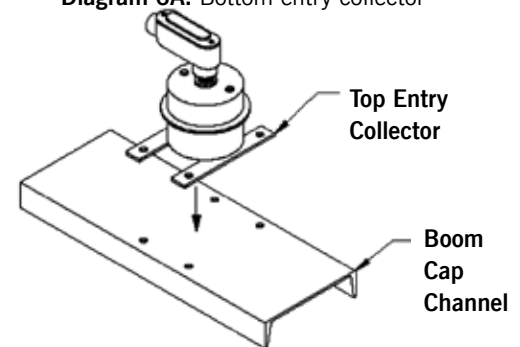

Diagram 6B. Top entry collector

Tagline Festoon Installation (diagram 6C)

- A. Bolt tagline bracket and an endstop to end of boom closest to the mast. Torque nuts (refer to hardware torque chart, page 14, for proper torque rating).
- B. Roll hoist/hoist trolley (by others) into place.
- C. Immediately bolt remaining tagline bracket and endstop into place at the front of boom. Torque nuts (refer to hardware torque chart, page 14, for proper torque rating).
- D. Bolt eyebolts to tagline brackets using two hexnuts per eyebolt.
- E. Loop the wire rope through one of the eyebolts and clamp the loop using cable clamps. Repeat this step at the other eyebolt while removing any slack from the wire rope.
- F. Adjust the eyebolts to achieve the desired cable tension and lock the eyebolts in place by tightening the hexnuts.
- G. Run the festoon cable through the S-hooks or wire rope trolleys (squeeze bottom of S-hooks to grip cable or hose).
- H. Wire the hoist per manufacturer's (SIC) instructions.
- I. Once all trolleys and end stops are installed, confirm that the trolleys contact the end stops appropriately and are not at risk of rolling past the stops.

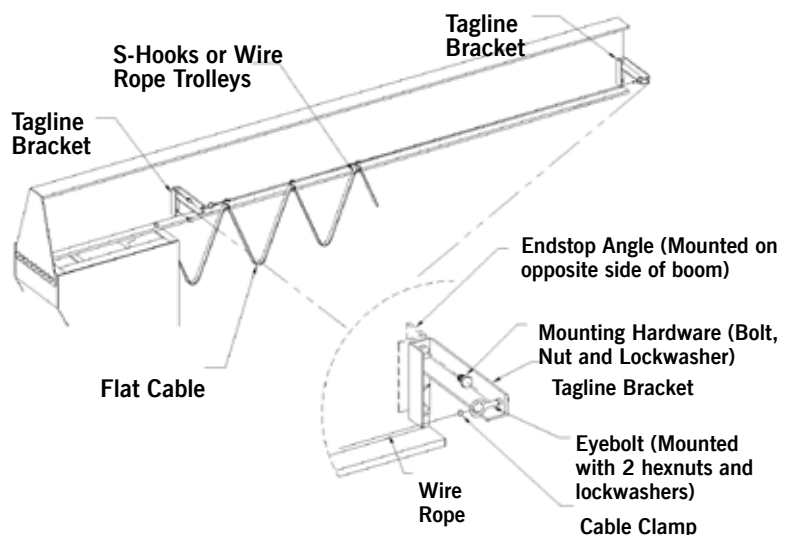

Diagram 6C. Tagline Festoon Installation.

JIB DRIVE CONTROLLER

The drive controller for the jib drive is pre-programmed at Gorbel for single speed, two speed, or three speed operation. For trouble shooting and general information, a brief summary of how the drive controller is designed to be used is included below. No additional programming is required. All options utilize an adjustable speed controller.



WARNING: The drive controller drive must only see its own internal voltage and not be connected to an external voltage source. Allowing 24 or 120 control voltage to go through the drive will PERMANENTLY DAMAGE the internal controls!

SINGLE SPEED OPTION

This option utilizes the drive ratio of the reducer and the ratio of the drive to driven sprockets to produce the standard jib rotation speed. These ratios are determined by the crane parameters (span, capacity, indoor, outdoor, etc.). The drive controller is then programmed for the motor to operate at normal speed (60 Hz).

TWO SPEED OPTION

This option varies the motor speed to determine the desired jib drive speeds. The motor controller is then programmed for the motor to operate at two different percentages of full speed based on the desired speeds specified by the customer at the time the order is placed.

THREE SPEED OPTION

This option is similar to the two speed option listed above. The motor controller is programmed for the motor to operate at three different percentages of full speed based on the desired speeds specified by the customer at the time the order is placed.

TIP: The two or three speed options listed above consist of two or three pre-set speeds, they are not infinitely variable during use.

DRIVE CONTROLLER PROGRAMMING

Gorbel pre-programs a number of parameters in the drive controller prior to shipment. The remaining parameters are left at the factory default settings. All parameters are stored on the EPM module. These parameters are as follows:

Parameter #	Name - SCL/SLM Drive	Name - SCF Drive	New Value - (Setting)
1	Line Voltage	Line Voltage	High or Low (see manual) - (01)
4	Stop Method	Stop Method	Ramp to Stop - (03)
5	Standard Speed Source	Standard Speed Source	Preset Speed - (02)
10	TB-13A Function Select	TB-13A Function Select	Run Reverse - (06)
11	TB-13B Function Select	TB-13B Function Select	Preset Speed - (04)
12	TB-13E Function Select	TB-13C Function Select	Preset Speed - (04)
17	Rotation	Rotation	Forward and Reverse - (02)
19	Acceleration	Acceleration	4 Seconds
20	Deceleration	Deceleration	4 Seconds
23	Minimum Frequency	Minimum Frequency	0 Hz
24	Maximum Frequency	Maximum Frequency	60 Hz
26	Motor Overload	Motor Overload	As Required (see manual)
31	Preset Speed 1	Preset Speed 1	As Required (0-60 Hz)
32	Preset Speed 2	Preset Speed 2	As Required (0-60 Hz)
36	Preset Speed 3	Preset Speed 3	As Required (0-60 Hz)

Preset speeds 2 and 3 are used only if required for two or three speed drives.

Parameter 50 contains the fault history of the last eight (8) faults with the most recent first. Pressing the “Mode” button three times will access this parameter.

Deceleration time: The deceleration time is factory set at 4 seconds. This can be adjusted to a shorter time period with the following warning. If the deceleration time is set to too short a time period, the drive controller will shut down and show an alarm. This is the result of the jib crane having too much inertia for the reducer and motor to stop in such a short time. If this occurs, increase the deceleration time.



WARNING: Do not remove or install the EPM module while power is applied to the drive controller. After removing power from the drive controller, wait three (3) minutes before removing the EPM module for the capacitors to discharge.

LIMIT SWITCH INSTALLATION

If applicable, install limit switches per the following instructions and **diagram 6D**, page 12.

The limit switches are designed to shut off the power to the rotation drive motor in a clockwise or counterclockwise direction and are not to serve as a spotting function.

Two limit switches are mounted on the safety channel at the rear of the head assembly. Each switch has an adjustable roller-type lever arm and is actuated by a limit switch ramp which must be attached to the mast pipe. The limit switch ramp must be field located, by the installer, to shut off power at the desired clockwise and counterclockwise points. The switches are pre-wired into the control panel of the jib crane and require no additional electrical hook-up.

Switch Adjustment:

After the jib crane has been erected and the safety channel, with the two limit switches, has been installed, the switch set-up is as follows:

1. Loosen the hex socket screw which locks the adjustable lever arm in position.
2. Loosen the lock pin hex nut which fastens the lever arm assembly to the limit switch.
3. Rotate the lever arm until it is perpendicular to the face of the mast pipe and then rotate it an additional 15° away from the side which will contact the limit switch ramp (15° counterclockwise for the upper limit switch and 15° clockwise for the lower limit switch). The additional 15° will prevent jamming of the lever arm when the lever arm contacts the limit switch ramp.
4. Adjust the roller so that it has an 1/8” maximum clearance to the face of the mast pipe.
5. Re-tighten both the hex socket screw and the lock pin hex nut.
6. Rotate the jib crane 360° and check to see if the roller comes in contact with the mast pipe. If the roller contacts the mast pipe, increase the clearance between the roller and the pipe until it does not.
7. Repeat this procedure for the second limit switch.

Ramp Installation:

Two rotation limits can be established, one in the clockwise direction and one in the counterclockwise direction. The **lower** switch will be the **clockwise** rotation limit switch and the **upper** switch will be the **counterclockwise** rotation limit switch. **Do not reverse the functions of the upper and lower limit switches.** Reversing the functions may cause the limit switch lever arm to hit the limit switch mounting bracket.

Clockwise Rotation Limit Switch Ramp Installation:

1. Place the jib in its clockwise limit position.
2. Position a limit switch ramp, with the beveled edge facing the switch lever arm roller, on the mast pipe to the left of the lower switch.
3. Slide the limit switch ramp along the surface of the mast pipe, into the roller lever arm, causing the lever arm to move. Stop moving the ramp when an audible click is heard from the switch.
4. Drill and tap two (2) 1/4"-20 holes in the mast pipe, centered in the two slots in the limit switch ramp.
5. Secure the limit switch ramp to the mast pipe using the two (2) tapped holes and 1/4"-20 hardware provided.
6. Adjust the limit switch ramp location to compensate for over travel (see the over travel adjustment instructions).

Counterclockwise Rotation Limit Switch Ramp Installation:

1. Place the jib in its counterclockwise limit position.
2. Position a limit switch ramp, with the beveled edge facing the switch lever arm roller, on the mast pipe to the right of the upper switch.
3. Repeat Steps 3 through 6 from "Clockwise Rotation Limit Switch Ramp Installation" instructions above.

Over Travel Adjustment Instructions:

All cranes will experience some over travel after power to the drive is shut off due to inertia of the load acquired during rotation. The amount of over travel is dependent on the application and size of the jib crane. In order to accurately compensate for over travel, it is necessary to test the rotation performance of the jib under full load and determine the actual over travel.

1. With the hoist at the end of the boom, lift a capacity load up one half the distance from the floor to the hoist.
2. Push the "ON" button to power controls.
3. Start rotating the jib crane in the direction of the previously installed limit switch ramp. It is important to give the jib crane enough starting distance before the ramp to accelerate to full speed.
4. When the limit switch reaches the desired rotation limit position, the lever arm will contact the ramp and the power to the drive motor will be shut off. Allow the jib crane to come to a full stop.
5. Measure the distance between the beveled edge of the ramp and the centerline of the roller on the switch arm.
6. Loosen the 1/4"-20 hardware holding the limit switch ramp to the mast pipe and slide the ramp towards the lever arm roller the distance measured in step 5.
7. Re-tighten the 1/4"-20 hardware holding the limit switch ramp to the mast pipe. Torque per chart on page 14.

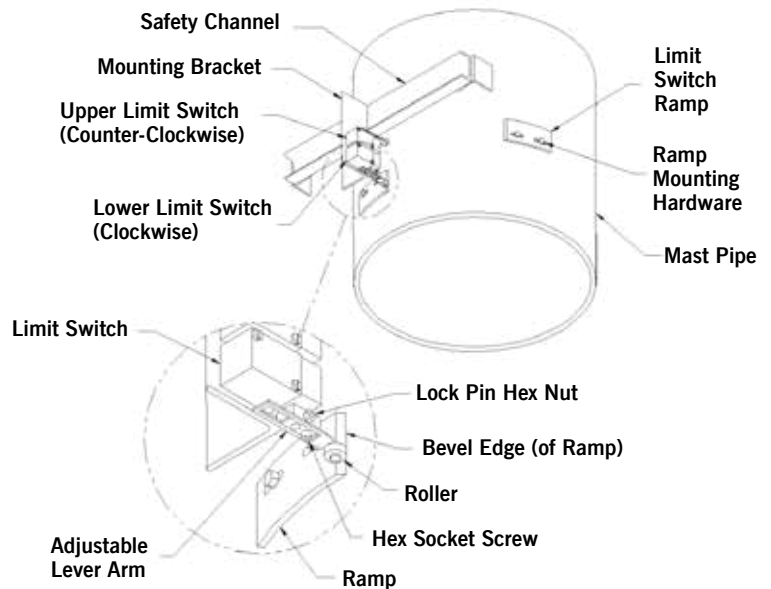

Diagram 6D. Limit Switch Installation.

Step 7 - Final Steps

TIP: Do not throw away this manual: maintenance schedule is on back cover.

- 7.1 Check to make sure all bolts are tightened and lockwashers are compressed.
- 7.2 Once all trolleys and end stops are installed, confirm that the trolleys contact the end stops appropriately and are not at risk of rolling past the stops.
- 7.3 If necessary, touch up with paint provided.
- 7.4 Keep Packing List, Installation Manual, General Arrangement Drawing and any other inserts together in a safe place.

Shut-Down Instructions

Whenever the operator leaves the crane, this procedure should be followed:

1. Raise all hooks to an intermediate position.
2. Spot the crane at an approved designated location.
3. Secure the beam in the shut-down position or storage area. If the crane is an outdoor application and it has a tie down loop, secure tightly especially in high wind areas.
4. Check the crane, hoist and hook storage positions to be sure there is no interference with other pieces of equipment that may be operating in the area.
5. Place all controls in the “**OFF**” position.
6. Open the main switch to the “**OFF**” position.
7. Make a visual check before leaving the crane.

Safety Warning and Precautions

Safety is very important when operating a jib crane. There are many safety warnings and precautions the operator should be aware of. These include, but are not limited to, the following:

- The jib can only be used to pick up a **MAXIMUM** of its **RATED CAPACITY**.
- The load will swing when lifted.
- Make sure the power is “**OFF**” prior to doing any electrical work or checking wires and connections.
- When loading, pick load directly up. Crane should not be used to pick up a load diagonally or out of the range of the span.
- On all baseplate mounted cranes, periodically check anchor bolts to make sure they are tight.
- Watch for wet spots: oil, water, etc. where the operator may slip.
- Check that all bolts are tight and have lockwashers.
- Make sure endstops are in place, are fully engaging the trolley and the endstop hardware is tight.
- Make sure that festooning cannot be snagged or pinched.
- Check for obstructions in crane travel.
- The operator should have full concentration on the crane and its surroundings at all times.



WARNING: Any changes in rolling effort or unusual noises must be immediately identified and corrected.

Troubleshooting Guide

Problem	Check	Yes	No
Jib does not rotate	1. Is AC contactor coil pulling in when ON is pressed and does it stay in?	See No. 2	Check fuses in jib panel. Check Pendant wiring. Check control transformer fuse. Check that the drive is not showing an alarm. Check that motor leads are secure. Tighten clutch (see page 8). Install the EPM module (see page 8) and ensure that it is completely seated in the drive unit.
	2. Is motor shaft turning? (With TEFC motors, if fan is blowing air, motor shaft is turning.)	See No. 3	
	3. Does shaft or drive reducer turn?	See No. 4	
	4. Is the EPM module installed in the drive controller?	See No. 5	
	5. Is the drive controller showing an error code?	See No. 6 and note the error.	
	6. Call factory and ask for Customer Service.		
Jib rotates in one direction only	1. Check pendant wiring.	See No. 2	Tighten clutch (see page 8).
	2. Is clutch properly adjusted?	See No. 3	
	3. Call factory and ask for Customer Service.		

If you are experiencing any other problems in the start-up or operation of your Gorbel® crane, please call 1-585-924-6262 or 1-800-821-0086 and ask for Customer Service.

Hardware Torque Chart

HARDWARE TORQUE		
HARDWARE SIZE	UNPLATED FINISH	PLATED FINISH
1/4"-20	8 FT-LBS	6 1/3 FT-LBS
3/8"-16	31 FT-LBS	23 FT-LBS
1/2"-13	76 FT-LBS	57 FT-LBS
5/8"-11	150 FT-LBS	112 FT-LBS
3/4"-10	266 FT-LBS	200 FT-LBS
7/8"-9	430 FT-LBS	322 FT-LBS

Spare Parts List (Call Gorbel® Dealer to order)

Description	Mast Diameter	P/N (Indoor)	P/N (Outdoor)
Motor	All	98725	98725
Reducer	14"	07114	07006
	16"	07116	07006
	18"	31371	07005
	20"	31371	07005
	24"	31373	07003
	30"	07130	07003
Clutch	14"	40200	40222
	16"	40200	40222
	18"	40200	40222
	20"	40201	40222
	24"	40201	40222
	30"	40202	40222
Hook Wrench	All	51912	None
Reducer Mtg. Bolt	14"	01979	04355
	16"	01979	04355
	18"	01979	04355
	20"	01979	04355
	24"	01979	03346
	30"	02026	03346
Reducer Mtg. Lockwasher	14"	01355	03373
	16"	01355	03373
	18"	01355	03373
	20"	01355	03373
	24"	01355	03286
	30"	03291	03286
Chain	14"-18"	05761	05767
	20"-30"	05764	05767
Connecting Link	14"-18"	05762	05768
	20"-30"	05765	05768
Jacking Screw	All	01758	01758
Chain Enclosure	14"	60220.2	60114.2
	16"	60230.2	60116.2
	18"	60218.2	60118.2
	20"	60220.2	60120.2
	24"	60224.2	60124.2
	30"	60230.2	60130.2
Chain Enclosure Mtg. Bolt	All	02148	02148
Chain Enclosure Mtg. Flatwasher	All	01220	01220
Chain Enclosure Mtg. Lockwasher	All	02097	02097
Drive Mtg. Bolt	All	01525	01525
Drive Mtg. Nut	All	03300	03300
Drive Mtg. Flatwasher	All	01302	01302
Drive Mtg. Lockwasher	All	03373	03373
Limit Switch	All	05798	05798
Limit Switch Lever Arm Only	All	05799	05799
Limit Switch Ramp	14"	32214	32214
	16"	32216	32216
	18"	32218	32218
	20"	32220	32220
	24"	32224	32224
	30"	32230	32230
Limit Switch Ramp Mtg. Bolt	All	02148	02148
Limit Switch Ramp Mtg. Starwasher	All	03436	03436

Appendix A: Securex Friction Torque Limiter Type C & T Installation & Maintenance Instructions (Size 30 Thru 280)



WARNING: Read and follow all instructions carefully.



WARNING: Disconnect and lock-out power before installation and maintenance. Working on or near energized equipment can result in severe injury or death.



WARNING: Do not operate equipment without guards in place. Exposed equipment can result in severe injury or death.



CAUTION: Periodic inspections should be performed. Failure to perform proper maintenance can result in premature product failure and personal injury.



CAUTION: All electrical work should be performed by qualified personnel and compliant with local and national electrical codes.

GENERAL:

Before assembly, the pressure plates, facings, and center member (sprocket, sheave, plate, etc.) should be free of oil, grease, dirt, and rust. The center member should have a 1.6-micron finish on the area where the friction facings rub to obtain maximum rated capacity and optimum life from the Torque Limiter.

ASSEMBLY:

Refer to the appropriate sketch (see below) and assemble on the torque limiter hub the following: (A) Friction facing, (B) Bushing, (C) Center member (not shown), (D) Friction facing, (E) Pressure plate, (F) Spring(s), (G) Pilot plate (95 to 170 size models only) or (H) Lock washer (30 to 85 size models only), (J) Adjusting nut. When assembling the friction torque limiter type C, please refer to the extra notes below.

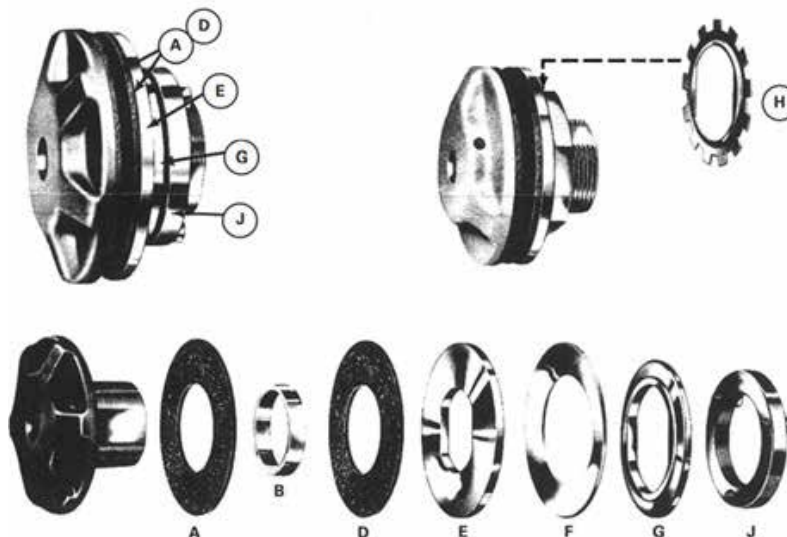

RUNNING-IN:

Torque Limiters should be run-in for the most consistent results. To run-in, adjust the Torque Limiter to 25% of the maximum single spring capacity and slip the center member approximately 50 RPM for approximately 4 minutes.

TORQUE SETTING PROCEDURES:

Type 30 ÷ 85: Loosen the locking screw (A) and tighten the adjusting nut with the proper spanner or hook wrench until a slight contact with the spring is established. Then tighten the adjusting nut further to obtain the pressure necessary to transmit the required torque without slipping. Now check if slip occurs at the required torque value and then tighten the locking screw. After the slip torque preset, the nut is locked in position by means of the appropriate locking washer.

SIZE 30

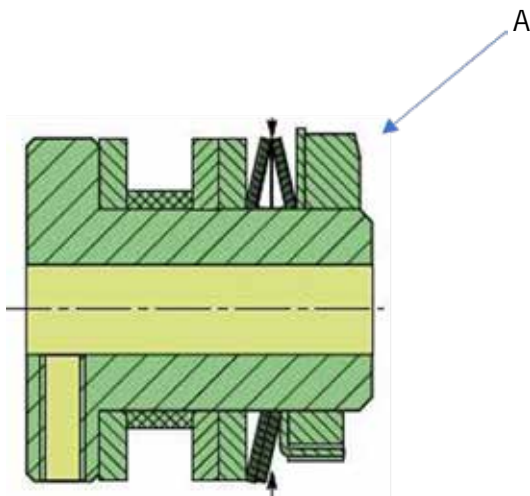

SIZE 40-85

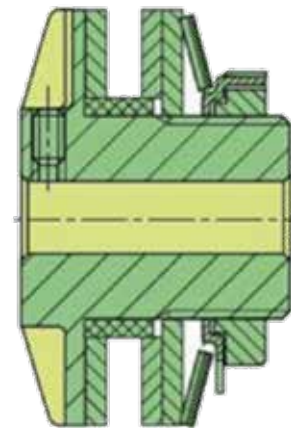

Type 95 ÷ 170: Slip torque is preset by adjustment of 4 or more screws on the nut (B), providing axial load to the disc spring. This system makes the adjustment easy. Apply springs load by loosening the adjusting bolts in approximately 60 degrees steps until no slip is observed under maximum load conditions in normal running mode. It is essential that all the bolts have equal adjustments or damage to friction facings will occur. The available diagrams give the approximate slipping torque in function of the number of turns of the adjusting bolts (the fraction refers to the number of faces of the bolts, example: 2/6 means turn 2 out 6 faces present on the bolt).

SIZE 95-170

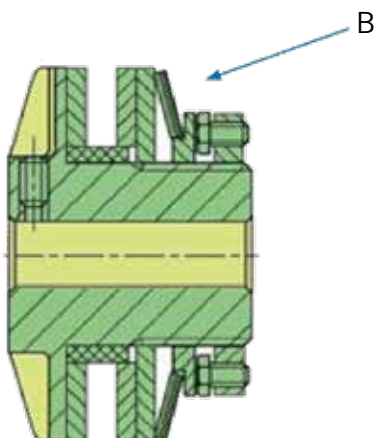

Type 200 and Up: These larger units have a series of smaller disc springs mounted on threaded holding pins which are threaded into the adjusting nut (D). Loosen the spring holding pins (C) and make pre-adjustment of the adjusting nut. Wind the adjusting nut by hand until tight against pilot plate. Ensure friction facings are concentric on the bushing and that the springs are correctly positioned on the pins.

Start tightening spring holding pins until minimal spring resistance is observed. Then, apply springs load by tightening the adjusting bolts in approximately 60 degree steps until no slip is observed under maximum load conditions in normal running mode. It is essential that all the bolts have equal adjustments or damage to friction facings will occur. The available diagrams give the approximate slipping torque in function of the number of turns of the adjusting bolts (the fraction refers to the number of faces of the bolts, example: 2/6 means turn 2 out 6 faces present on the bolt).

Having set the torque limiter as outlined above, it is common practice to advance the bolts a further 60 degrees to prevent excess on machine start-up. Lock the nut by tightening the two screws located in it.

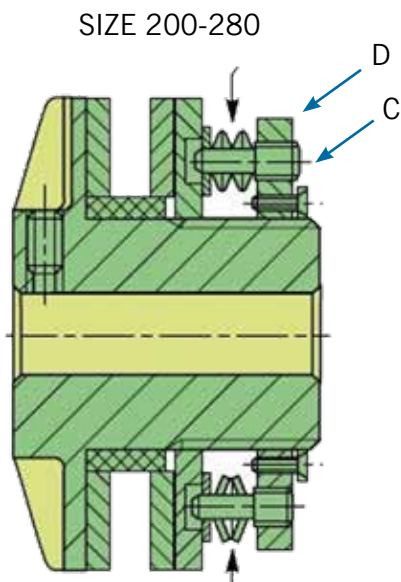

TORQUE CHECKING:

To check the Torque Limiter for the required slip torque, mount the Torque Limiter on a stub shaft and fasten in a bench vise. Wrap the center member (if a sprocket) with a chain and load the chain with weights until the center member rotates. If the center member is a plate, attach a chain or cable to the center member. The breakaway torque will be equal to the radius of the center member in feet times the weight in lbs. on the chain. The breakaway torque should be slightly higher (5% to 10%) than the required slip torque. If the slip torque is too high or too low, readjust torque limiter as per torque setting procedures above. After readjustment, check the breakaway torque in the manner outlined above and repeat adjustments if necessary.

MAINTENANCE:

The Securex series torque limiters do not normally require any maintenance. However, as with all friction torque limiters, regular inspection of the friction surfaces and other related components is highly recommended. The friction pads should be replaced when they have each worn to half of their original, new thickness. At periodic intervals, or if proper torque is not being maintained, inspect Torque Limiter for presence of oil, grease, moisture, or corrosion on the driving surfaces and for proper setting of spring load. Clean and adjust as required. Friction facings and bushings are the only parts that should normally require replacement.

CAUTION:

The operating characteristics and capacity of Torque Limiters are affected by atmospheric conditions, moisture, lubricants, and surface corrosion. To illustrate, the life of the friction facings may be greatly reduced by rust on the center plate. The Torque Limiter ratings are based on average conditions. For best results, the Torque Limiter should be adjusted under conditions like those in which it will be used.

HOW TO REPLACE FRICTION DISCS:

Please refer to the appropriate sketch (see above).

1. Remove the drive chain / belt from the torque limiter center member.
2. Loosen adjusting nut (J).
3. Disassemble all components in the following order: Remove (G) Pilot plate (95 to 170 size models only) or (H) Lock washer (30 to 85 size models only), (F) Spring(s), (E) Pressure plate, (D) Friction facing, (C) Center member (not shown), (B) Bushing and (A) Friction facing.
4. Reassemble by placing new friction discs on both sides of a new sprocket and a new sintered bushing. Please refer to the assembly instructions above.



EXTRA NOTES FOR TYPE C ASSEMBLING PROCEDURES:

When assembling type C friction torque limiter, make sure that misalignments are within the allowed values indicated below:

Type	Max Torque	Springs	Max Misalignment		N		O	P	Q	R	S	T	Chain Sprocket	
			Parallel	Angular	Min.	Max.							Teeth	Pitch
C 5/30	5	2												
C 10/30	10	2	0,20	30°	11	22	55	37	22,5	57,1	31	1,5	16	3/8
C 15/40	15	1												
C 28/40	28	2	0,20	30°	8	40	55	55	25	75,2	28	2	22	3/8
C 40/40	40	3												
C 30/45	30	1												
C 55/45	55	2	0,25	30°	8	40	59,5	55	25	75,2	33	1,5	22	3/8
C 70/45	70	3												
C 70/65	70	1												
C 120/65	120	2	0,25	30°	15	48	85	70	32	106,2	50	3	18	5/8
C 130/85	130	1												
C 240/85	240	2	0,35	30°	15	60	100	90	42	138	55	3	20	3/4
C190/95	190	1												
C 340/95	340	2	0,35	30°	15	60	110	90	42	138	66	3	20	3/4
C 350/120	350	1												
C 650/120	650	2	0,40	30°	20	80	130	120	50	183,5	77	3	20	1"
C 650/140	650	1												
C 1200/140	1200	2	0,50	30°	25	100	149	130	60	199,5	86	3	22	1"
C 1000/170	1000	1												
C 1800/170	1800	2	0,50	30°	30	100	170	158	74	231,6	93	3	26	1"
C 2200/200	2200	24												
C 4000/200	4000	24	0,50	30°	35	100	194	150	85	264	105	3	30	1"
C 3800/254	3800	32												
C 6800/254	6800	32	0,80	30°	50	150	255	230	130	390,7	120	5	36	1" 1/4
C 5500/280	5500	32												
C 10000/280	10000	32	0,80	30°	50	150	255	230	130	390,7	120	5	36	1" 1/4

Crane Operator Instructions

TIP: Be sure your installers, maintenance personnel, and operators realize this jib can only be used to pick up a **maximum** of its **rated capacity**.

Overhead cranes and jib cranes generally handle materials over working areas where there are personnel. Therefore, it is important for the Crane Operator to be instructed in the use of the crane and to understand the severe consequences of careless operation.

It is not intended that these suggestions take precedence over existing plant safety rules and regulations or OSHA regulations. However, a thorough study of the following information should provide a better understanding of safe operation and afford a greater margin of safety for people and machinery on the plant floor. It must be recognized that these are suggestions for the Crane Operator's use. It is the responsibility of the owner to make personnel aware of all federal, state, and local rules and codes, and to make certain operators are properly trained.

Qualifications

Crane operation, to be safe and efficient, requires skill: the exercise of extreme care and good judgment, alertness and concentration, and rigid adherence to proven safety rules and practices as outlined in applicable and current ANSI and OSHA safety standards. In general practice, no person should be permitted to operate a crane:

- Who cannot speak the appropriate language or read and understand the printed instructions.
- Who is not of legal age to operate this type of equipment.
- Whose hearing or eyesight is impaired (unless suitably corrected with good depth perception).
- Who may be suffering from heart or other ailments which might interfere with the operator's safe performance.
- Unless the operator has carefully read and studied this operation manual.
- Unless the operator has been properly instructed.
- Unless the operator has demonstrated his instructions through practical operation.
- Unless the operator is familiar with hitching equipment and safe hitching equipment practices.

Handling the Jib Boom Motion

Before using the boom of the jib crane, the operator should be sure the hook is high enough to clear any obstruction. Before a load is handled by the crane, the jib boom should be brought into position so that it is directly over the load. Start the jib boom slowly and bring it up to speed gradually. Approaching the place where it is desired to stop the jib, reduce the boom speed.

Handling the Trolley Motion

Before a load is handled, the hoist should be positioned directly over the load that is to be handled. When the slack is taken out of the slings, if the hoist is not directly over the load, bring it directly over the load before hoisting is continued. Failure to center the hoist over the load may cause the load to swing upon lifting. Always start the trolley motion slowly and reduce the trolley speed gradually.

Handling the Hoist Motion

Refer to the lifting (hoist) equipment's operating instructions.

General Suggestions

Know Your Crane

Crane operators should be familiar with the principal parts of a crane and have a thorough knowledge of crane control functions and movements. The crane operator should be required to know the location and proper operation of the main conductor disconnecting means for all power to the attachments on the crane.

Responsibility

Each crane operator should be held directly responsible for the safe operation of the crane. Whenever there is any doubt as to SAFETY, the crane operator should stop the crane and refuse to handle loads until: (1) safety has been assured or (2) the operator has been ordered to proceed by the supervisor, who then assumes all responsibility for the SAFETY of the lift.

Do not permit **ANYONE** to ride on the hook or a load.

Inspection

Test the crane movement and any attachments on the crane at the beginning of each shift. Whenever the operator finds anything wrong or apparently wrong, the problem should be reported immediately to the proper supervisor and appropriate corrective action taken.

Operating Suggestions

One measure of a good crane operator is the smoothness of the crane operation. The good crane operator should **know** and follow these proven suggestions for safe, efficient crane handling.

1. The crane should be moved smoothly and gradually to avoid abrupt, jerky movements of the load. Slack must be removed from the sling and hoisting ropes before the load is lifted.
2. Center the crane over the load before starting the hoist to avoid swinging the load as the lift is started. Loads should not be swung by the crane to reach areas not under the crane.
3. Crane-hoisting ropes should be kept vertical. Cranes shall not be used for side pulls.
4. Be sure everyone in the immediate area is clear of the load and aware that a load is being moved.
5. Do not make lifts beyond the rated load capacity of the crane, sling chains, rope slings, etc.
6. Make certain that before moving the load, load slings, load chains, or other lifting devices are fully seated in the saddle of the hook with hook latch closed (if equipped with hook latch).
7. Check to be sure that the load and/or bottom block is lifted high enough to clear all obstructions when moving boom or trolley.
8. At no time should a load be left suspended from the crane unless the operator has the push button with the power on, and under this condition keep the load as close as possible to the floor to minimize the possibility of an injury if the load should drop. When the crane is holding a load, the crane operator should remain at the push button.
9. Do not lift loads with sling hooks hanging loose. If all sling hooks are not needed, they should be properly stored, or use a different sling.
10. All slings or cables should be removed from the crane hooks when not in use (dangling cables or hooks hung in sling rings can inadvertently snag other objects when the crane is moving).
11. Operators shall not carry loads and/or empty bottom blocks over personnel. Particular additional caution should be practiced when using magnet or vacuum devices. Loads, or parts of loads, held magnetically could drop. Failure to power magnets or vacuum devices can result in dropping the load. Extra precaution should be exercised when handling molten metal in the proximity of personnel.
12. Whenever the operator leaves the crane the following procedure should be followed:
 - Raise all hooks to an intermediate position.
 - Spot the crane at an approved designated location.
 - Place all controls in the "off" position.
 - Open the main switch to the "off" position.
 - Make visual check before leaving the crane.
13. In case of emergency or during inspection, repairing, cleaning or lubrication, a warning sign or signal should be displayed and the main switch should be locked in the "off" position. This should be done whether the work is being done by the crane operator or by others.
14. Contact with rotation stops or trolley end stops shall be made with extreme caution. The operator should do so with particular care for the safety of persons below the crane, and only after making certain that any persons on other cranes are aware of what is being done.
15. ANY SAFETY FEATURES AND MECHANISMS BUILT-IN OR OTHERWISE PROVIDED WITH THE CRANE BY GORBEL ARE REQUIRED FOR THE SAFE OPERATION OF THE CRANE. DO NOT, UNDER ANY CIRCUMSTANCES, REMOVE OR OTHERWISE IMPAIR OR DISABLE THE PROPER FUNCTIONING OF ANY CRANE SAFETY MECHANISMS OR FEATURES BUILT-IN OR OTHERWISE PROVIDED BY GORBEL FOR SAFE OPERATION OF THE CRANE. ANY REMOVAL, IMPAIRMENT OR DISABLING OF ANY SUCH SAFETY MECHANISMS OR FEATURES OR OTHER USE OR OPERATION OF THE CRANE WITHOUT THE COMPLETE AND PROPER FUNCTIONING OF ANY SUCH SAFETY MECHANISMS OR FEATURES AUTOMATICALLY AND IMMEDIATELY VOIDS ANY AND ALL EXPRESS AND IMPLIED WARRANTIES OF ANY KIND OR NATURE.

Limited Warranty

It is agreed that the equipment purchased hereunder is subject to the following LIMITED warranty and no other. Gorbel Incorporated ("Gorbel") warrants the manual push-pull Work Station Cranes, Jib Crane, and Gantry Crane products to be free from defects in material or workmanship for a period of ten years or 20,000 hours use from date of shipment. Gorbel warrants the Motorized Work Station Cranes and Jib Crane products to be free from defects in material or workmanship for a period of two years or 4,000 hours use from the date of shipment. This warranty does not cover Gantry Crane wheels. This warranty shall not cover failure or defective operation caused by operation in excess of recommended capacities, misuses, negligence or accident, and alteration or repair not authorized by Gorbel. No system shall be field modified after manufacture without the written authorization of Gorbel, Inc. Any field modification made to the system without the written authorization of Gorbel, Inc. shall void Gorbel's warranty obligation. OTHER THAN AS SET FORTH HEREIN, NO OTHER EXPRESS WARRANTIES, AND NO IMPLIED WARRANTIES, ORAL OR WRITTEN, INCLUDING BUT NOT LIMITED TO THE WARRANTIES OF MERCHANTABILITY OR FITNESS FOR PARTICULAR PURPOSE, ARE MADE BY GORBEL WITH RESPECT TO ITS PRODUCTS AND ALL SUCH WARRANTIES ARE HEREBY SPECIFICALLY DISCLAIMED. GORBEL SHALL NOT BE LIABLE UNDER ANY CIRCUMSTANCES FOR ANY INCIDENTAL, SPECIAL AND/OR CONSEQUENTIAL DAMAGES WHATSOEVER, WHETHER OR NOT FORESEEABLE, INCLUDING BUT NOT LIMITED TO DAMAGES FOR LOST PROFITS AND ALL SUCH INCIDENTAL, SPECIAL AND/OR CONSEQUENTIAL DAMAGES ARE HEREBY ALSO SPECIFICALLY DISCLAIMED. Gorbel's obligation and Purchaser's or end user's sole remedy under this warranty is limited to the replacement or repair of Gorbel's products at the factory, or at the discretion of Gorbel, at a location designated by Gorbel. Purchaser or end user shall be solely responsible for all freight and transportation costs incurred in connection with any warranty work provided by Gorbel hereunder. Gorbel will not be liable for any loss, injury or damage to persons or property, nor for damages of any kind resulting from failure or defective operation of any materials or equipment furnished hereunder. Components and accessories not manufactured by Gorbel are not included in this warranty. Purchaser's or end user's remedy for components and accessories not manufactured by Gorbel is limited to and determined by the terms and conditions of the warranty provided by the respective manufacturers of such components and accessories.

A) DISCLAIMER OF IMPLIED WARRANTY OF MERCHANTABILITY

Gorbel and Purchaser agree that any claim made by Purchaser which is inconsistent with Gorbel's obligations and the warranty remedies provided with Gorbel's products, and in particular, special, incidental and consequential damages, are expressly excluded.

B) DISCLAIMER OF IMPLIED WARRANTY OF FITNESS FOR PARTICULAR PURPOSE

Gorbel and Purchaser agree that the implied warranty of fitness for particular purpose is excluded from this transaction and shall not apply to the goods involved in this transaction.

C) DISCLAIMER OF EXPRESS WARRANTY

Gorbel's agents, or dealer's agents, or distributor's agents may have made oral statements about the machinery and equipment described in this transaction. Such statements do not constitute warranties, and Purchaser agrees not to rely on such statements. Purchaser also agrees that such statements are not part of this transaction.

D) DISCLAIMER OF SPECIAL, INCIDENTAL AND CONSEQUENTIAL DAMAGES

Gorbel and Purchaser agree that any claim made by Purchaser which is inconsistent with Gorbel's obligations and the warranty remedies provided with Gorbel's products, and in particular, special, incidental and consequential damages, are expressly excluded.

E) DEALER OR DISTRIBUTOR NOT AN AGENT

Gorbel and Purchaser agree that Purchaser has been put on notice that dealer or distributor is not Gorbel's agent in any respect for any reason. Gorbel and Purchaser also agree that Purchaser has been put on notice that dealer or distributor is not authorized to incur any obligations or to make any representations or warranties on Gorbel's behalf other than those specifically set forth in Gorbel's warranty provided in connection with its product.

F) MERGER

This warranty agreement constitutes a final and complete written expression of all the terms and conditions of this warranty and is a complete and exclusive statement of these terms.

G) PAINTING

Every crane (excluding components) receives a quality paint job before leaving the factory. Unfortunately, no paint will protect against the abuses received during the transportation process via common carrier. We have included at least one (1) twelve ounce spray can for touchup with each crane ordered (unless special paint was specified). If additional paint is required, contact a Gorbel Customer Service Representative at 1-800-821-0086 or 1-585-924-6262.

Title and Ownership:

Title to the machinery and equipment described in the foregoing proposal shall remain with Gorbel and shall not pass to the Purchaser until the full amount herein agreed to be paid has been fully paid in cash.

Claims and Damages:

Unless expressly stated in writing, goods and equipment shall be at Purchaser's risk on and after Seller's delivery in good shipping order to the Carrier. Gorbel shall in no event be held responsible for materials furnished or work performed by any person other than it or its authorized representative or agent.

Cancellations:

If it becomes necessary for the purchaser to cancel this order wholly or in part, he shall at once so advise Gorbel in writing. Upon receipt of such written notice all work will stop immediately. If the order entails only stock items, a flat restocking charge of 15% of the purchase price will become due and payable by the Purchaser to Gorbel. Items purchased specifically for the canceled order shall be charged for in accordance with the cancellation charges of our supplier plus 15% for handling in our factory. The cost of material and/or labor expended in general fabrication for the order shall be charged for on the basis of total costs to Gorbel up to the time of cancellation plus 15%.

Returns:

No equipment, materials or parts may be returned to Gorbel without express permission in writing to do so.

Extra Charge Delay: If Purchaser delays or interrupts progress of Seller's performance, or causes changes to be made, Purchaser agrees to reimburse Gorbel for expense, if any, incident to such delay.

Changes and Alterations:

Gorbel reserves the right to make changes in the details of construction of the equipment, as in its judgment, will be in the interest of the Purchaser; will make any changes in or additions to the equipment which may be agreed upon in writing by the Purchaser; and Gorbel is not obligated to make such changes in products previously sold any customer.

Third Party Action:

Should Gorbel have to resort to third party action to collect any amount due after thirty (30) days from date of invoice, the Purchaser agrees to pay collection costs, reasonable attorney's fees, court costs and legal interest.

OSHA Responsibilities:

Gorbel agrees to full cooperate with Purchaser in the design, manufacture or procurement of safety features or devices that comply with OSHA regulations. In the event additional equipment or labor shall be furnished by Gorbel, it will be at prices and standard rates then in effect, or as may be mutually agreed upon at the time of the additional installation.

Equal Employment Opportunity:

Gorbel agrees to take affirmative action to ensure equal employment opportunity for all job applicants and employees without regard to race, color, age, religion, sex, national origin, handicap, veteran, or marital status. Gorbel agrees to maintain non-segregated work facilities and comply with rules and regulations of the Secretary of Labor or as otherwise provided by law or Executive Order.

