

GS VFD Electric Chain Hoist

Installation, Operation and Maintenance Manual



Part Number: MAN-US100 R01 Released 5/2026

Find manual updates at:

<https://www.gorbel.com/service-support/archived-installation-manuals>



Scan to Register
Your Warranty

Rated Loads

1/2, 1 Ton and 2 Ton

Follow all instructions and warnings for installing, operating, inspecting and maintaining this electric chain hoist.

Gorbel Customer Order No. / Serial No.

Gorbel Dealer

Questions? Concerns? Comments?

Please call (800) 821-0086 (US and Canada) or
(585) 924-6262 (Outside US)



WARNING



This product contains chemicals known to the State of California to cause cancer and birth defects or other reproductive harm. For more information: www.P65warnings.ca.gov

Table of Contents

Section 1 - Safety and Hoist Overview	1-1
Hoist Safe Operating Practices.....	1-2
Safe Operating Tag.....	1-3
Section 2 - GS VFD Hoist Technical Information	2-1
New Hoist Components Overview	2-1
Variable Frequency Drive.....	2-2
User Interface.....	2-3
High Voltage Rectifier and Low Voltage PCBs.....	2-4
Brake Side Components.....	2-5
Conductix Pendant and Speed Settings.....	2-6
Technical Specifications	2-8
Technical Information	2-9
Operating Conditions	2-10
Hoist Dimensions.....	2-11
Section 3 - Delivery, Transportation and Storage	3-1
Delivery	3-1
Transport.....	3-1
Storage Conditions	3-1
Section 4 - Installation	4-1
Installer Qualifications	4-1
General.....	4-1
Unpacking the Hoist.....	4-2
Unpacking the Hoist, Continued	4-3
Inspection Before Assembly.....	4-3
Assembly	4-4
Section 5 - Operation	5-1
Hoist Operator Qualifications.....	5-1
Hoist Inspection Before Starting Work	5-2
Setting Operational Parameters with the User Interface (UI).....	5-5
Menu 00 Parameter Table.....	5-12
Menu 00 Parameter Table, 2-Ton Hoist Differences.....	5-16

Table of Contents, Continued

Section 6 - Maintenance	6-1
Load and Suspension Hooks	6-2
Load Chain, Chain Guide and Hold Down	6-3
Load Chain Testing Procedure	6-4
Replacing the Load Chain and the Hold Down	6-4
Load Chain Assembly - Single Fall Hoist	6-5
Load Hook Assembly - Single Fall Version	6-6
Load Chain and Load Hook Assembly - Double Fall Version	6-7
Lift Limiter Assembly	6-8
Chain Bag Assembly and Filling	6-9
Checking the Hoist Brake	6-9
Checking the Hoist Brake Air Gap	6-10
Hoist Brake Replacement	6-11
Lift Motor Components	6-12
Checking the Electric Limit Switches	6-13
Safety Clutch	6-13
Safety Clutch Adjustment	6-14
Lubrication	6-15
 Section 7 - Troubleshooting	 7-1
Troubleshooting Overview for the GS VFD Hoist	7-1
General Visual Inspection - All PCBs and Hoist Compartments	7-2
Troubleshooting Tables	7-3
VFD Alarms	7-9
Hoist PCB Schematics and Interconnecting Diagrams	7-11
Full Wiring Diagrams	7-16
 Limited Warranty	 8-1

Section 1 - Safety and Hoist Overview

Warnings and Important Information

Introduction

This manual contains important information for installation, operation and maintenance of your Gorbel® hoist. It is strongly recommended that you read and understand this manual prior to installing, operating or maintaining your hoist.

Safety Symbol Conventions

The following signal words and symbols are used in this manual to highlight hazardous situations.

CAUTION!



Caution indicates a potentially hazardous situation, which may result in minor or moderate injury or property damage.



WARNING!



Warning indicates a hazardous situation, which could result in serious injury or death and property damage.



HAZARD!



Hazard indicates a hazardous situation, which could result in serious injury or death and property damage.



ELECTRICAL SHOCK HAZARD!



Electrical Shock Hazard indicates a hazardous situation, which could result in serious injury or death and property damage.



HEAT HAZARD!



Heat Hazard indicates a hazardous situation, which could result in serious injury and property damage.



Hoist Safe Operating Practices

General

WARNING!



Read all instructions before installing or operating the hoist. Forward this manual to the hoist operator. Failure to operate the hoist as directed in the manual may cause injury.

Safe Operating Practices are the most important factor for minimizing the possibility of personal injury to the operator and those working in the area, or damage to property, equipment, or material.

No operator should be permitted to use the equipment who is not familiar with its operation, is not physically or mentally fit, or has not been schooled in Safe Operating Practices. The misuse of hoists can lead to hazards which cannot be protected against by mechanical means. These hazards can only be avoided by the exercise of Safe Operating Practices, care, and common sense.

Safe Operating Practices also involve a program of periodic inspection and preventive maintenance covered in [Section 6](#) of this manual. Part of an operator's training should be an awareness of potential malfunctions/hazards requiring adjustments or repairs, and bringing these to the attention of a supervisor for corrective action.

Supervisors and managers also have an important role to play in any safety program by ensuring that a maintenance schedule is adhered to, and that the equipment provided for operators is suitable for the job intended without violation of one or more of the rules covering Safe Operating Practices and good common sense.

The Safe Operating Practices shown are taken in part from the following publications:

- American National Standard Institute (ANSI)
- Safety Standards for Cranes, Derricks, Hoists
- ANSI B30.17 - Overhead Cranes and Monorail Systems
- ANSI B30.16 - Overhead Hoists

Do's and Don'ts for Safe Operation of Hoists

The following are Do's and Don'ts for safe operation of overhead hoists. These rules can make an operator aware of dangerous practices to avoid and precautions to take for their own safety and the safety of others. Frequent examinations and periodic inspections of the equipment as well as observance of safety rules may save lives, time and money.

DON'TS - HOISTS

1. Do not allow any unqualified personnel to operate hoist.
2. Never lift or transport a load until all personnel are clear.
3. Do not transport a load over personnel.
4. Never pick up a load beyond the rated capacity appearing on the hoist. Overloading can also be caused by jerking the load, and by static overload.

5. Never carry personnel on the hook or the load.
6. Do not operate hoist if you are not physically fit.
7. Do not operate hoist to extreme limits of chain travel without first checking for proper limit switch action.
8. Avoid impact between two hoists or between hoist and end stop.
9. Do not tamper with or adjust any parts of the hoist unless authorized to do so.
10. Never use the load chain as a sling.
11. Do not divert attention from the load while operating the hoist.
12. Never leave a suspended load unattended.
13. Do not use limit switch(es) for normal operating stop(s). These are safety devices only and should be checked on a regular basis for proper operation.
14. Never operate a hoist that has an apparent or suspected mechanical or electrical defect.
15. Do not use load chain as a ground for welding. Never touch a live welding electrode to the load chain.
16. Do not jog controls unnecessarily. The VFD will prevent high current spikes to the motor, however, rapid switching may cause motor starts while the brake is still engaged, prematurely wearing the clutch.
17. Do not operate the hoist if the load is not centered under the hoist.
18. Do not operate the hoist if the chain is twisted, kinked, or damaged.
19. Do not remove or obscure hoist labels.
20. Do not disassemble or reassemble components while the hoist is energized. Never "Hot-Swap" components.

DO'S - HOISTS

1. Read and follow manufacturer's instructions and installation and maintenance manuals.
2. When repairing or maintaining a hoist, use only manufacturer's recommended parts and materials.
3. Read and follow all instruction and warning information on or attached to a hoist.
4. Remove the hoist from service and thoroughly inspect and repair it if unusual performance or visual defects such as peculiar noises, jerky operations, travel in improper direction, or obviously damaged parts are noticed.
5. Follow the regular schedule of inspection in [Section 6](#) of this manual, and maintain records for all hoists with special attention given to hooks, load chains, brakes, and limit switches.
6. Check operation of brakes for excessive drift.
7. Check for damaged hooks and load chain.

DO'S - HOISTS, CONTINUED

8. Keep load chain clean and well maintained.
9. Check the load chain for improper seating, twisting, kinking, wear, or other defects before operating the hoist.
10. Make sure a load clears neighboring machinery, or other obstructions when raising, lowering, or transiting the load.
11. Center hoist over the load before operating.
12. Avoid swinging of load or load hook when transiting the hoist and load.
13. Be sure the load attachment is properly seated in the saddle of the hook. Balance the load correctly before lifting. Avoid hook tip loading.
14. Pull in a straight line, so that neither hoist body nor load chain are angled around an object.
15. Take up slack slowly.
16. Know the hand signals for hoisting, cross travel, and crane travel if working with cab-operated hoists or cranes. Operators should accept signals of only those persons authorized to give them.

Safe Operating Tag

The safe operating tag shown in **Diagram 1-1** is supplied with the electric chain hoist.

If the tag is not attached to the control pendant cable of the hoist, order a replacement tag from Gorbel through the dealer and install it on the control pendant of the hoist. The tag is provided in English on one side for US customers, and in Spanish on the other side for customers in Mexico.

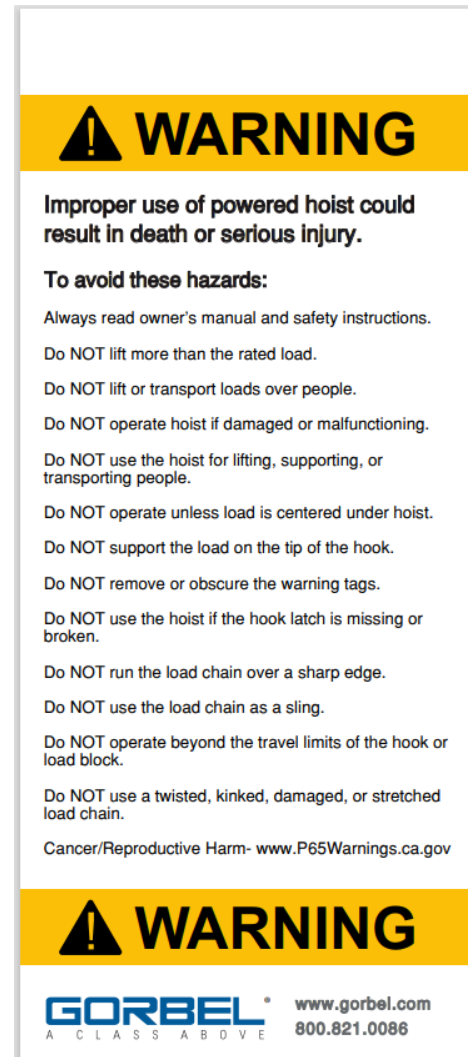

Diagram 1-1. Safe Operating Tag.

Electrical Design Standards

NOTICE: Each Gorbel® Electric Chain Hoist is built in accordance with the specifications contained herein and at the time of manufacture complied with our interpretation of applicable sections of the American Society of Mechanical Engineers Code B30.16 “Overhead Hoists”, the National Electrical Code (ANSI/NFPA 70) and the Occupational Safety and Health Act.

Since OSHA states the National Electrical Code applies to all electric hoists, installers are required to provide current overload protection and grounding (on the branch circuit section) in keeping with the code. Check each installation for compliance with the application, operation and maintenance sections of these articles.

This page intentionally left blank.

Section 2 - GS VFD Hoist Technical Information

ELECTRICAL SHOCK HAZARD!

Hazardous voltages are present in the electric chain hoist and in connections between components. **Contact with connected electrical circuits may cause death or serious injury.**



Before removing covers, switch off and de-energize the supply of electricity to the equipment. Lockout and tag the supply device in the 'OFF' position.



To allow time for high voltage capacitance to dissipate, **wait at least 10 minutes before removing covers from the device.**

HEAT HAZARD!



The heat generated by the GS VFD Hoist brake resistors and motor could result in serious injury or property damage. Allow the aluminum covers of the hoist to cool before touching them.



New Hoist Components Overview

Gorbel VFD Hoist was designed to respond to demand for a hoist that has the benefits of a Variable Frequency Drive. The overall design of the GS VFD Hoist is mechanically very similar to the GS hoists that came before it, but the Variable Frequency Drive components are new. Refer to **Diagram 2-1**, which reveals the various major components of the hoist. The Braking Resistor Cap, the Brake Housing Cap and the Motor Cap are aluminum for enhanced heat dissipation. Table 2-1 shows standard components which are the same as GS Hoist versions:

• Medium Hoist Body (070)	• Brake (203 DC)
• Motor (Size 71)	• Upper Hook Suspension
• Clutch	• Single and Double Hole Suspension Plates
• Chain Bag	• Push Trolley
• All bolts and fasteners	• Pendant (Conductix with dual-speed Up/Down and E-Stop)

Table 2-1. GS VFD and GS Chain Hoist Common Components.

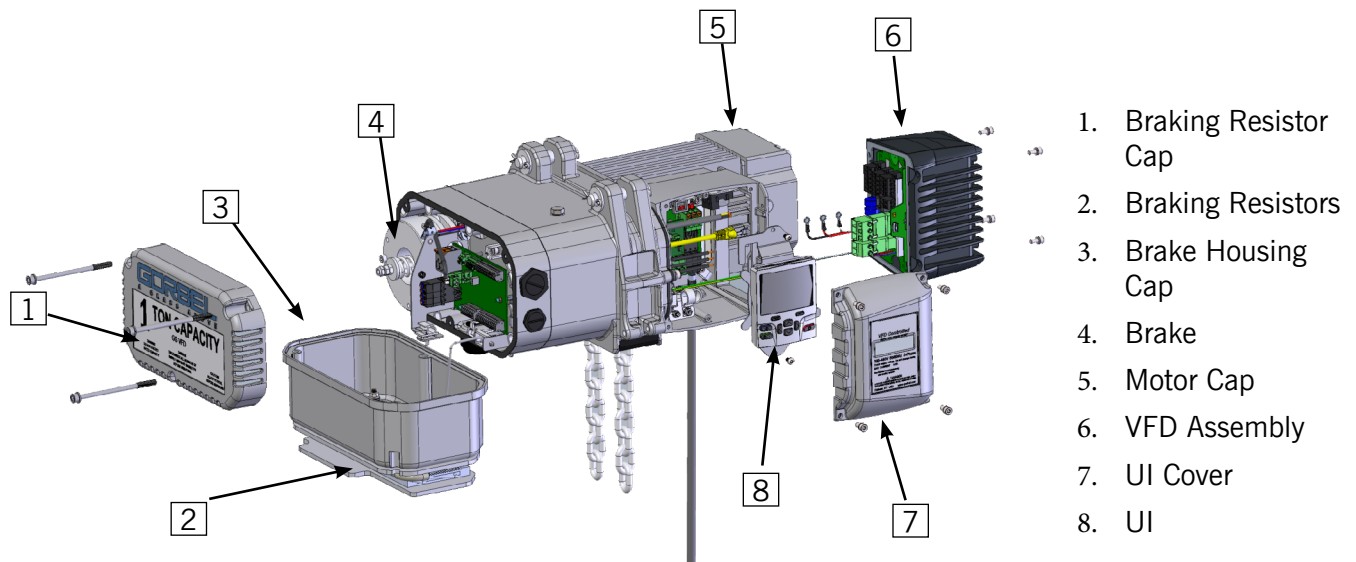

Diagram 2-1. GS VFD Chain Hoist Major Components.

New Hoist Components Overview, continued

Variable Frequency Drive

The Variable Frequency Drive (VFD) assembly is located as shown in **Diagram 2-2**. The VFD is a replaceable, potted assembly; no internal components are serviceable, and the unit must be replaced as a complete assembly if a failure occurs.

The VFD controls the voltage and frequency applied to the motor, which will control the speed at which the motor moves the load. The ramp feature in the VFD minimizes clutch wear by easing impulse loads.

The VFD and the High Voltage PCB that interfaces it with the hoist are hardwired for a specific voltage (**230 VAC or 460 VAC**). **A hoist configured to run on 230 VAC cannot run on 460 VAC.**

The connectors on the VFD PCB are as shown in **Section 7** [VFD Plug/Jack Locations](#).

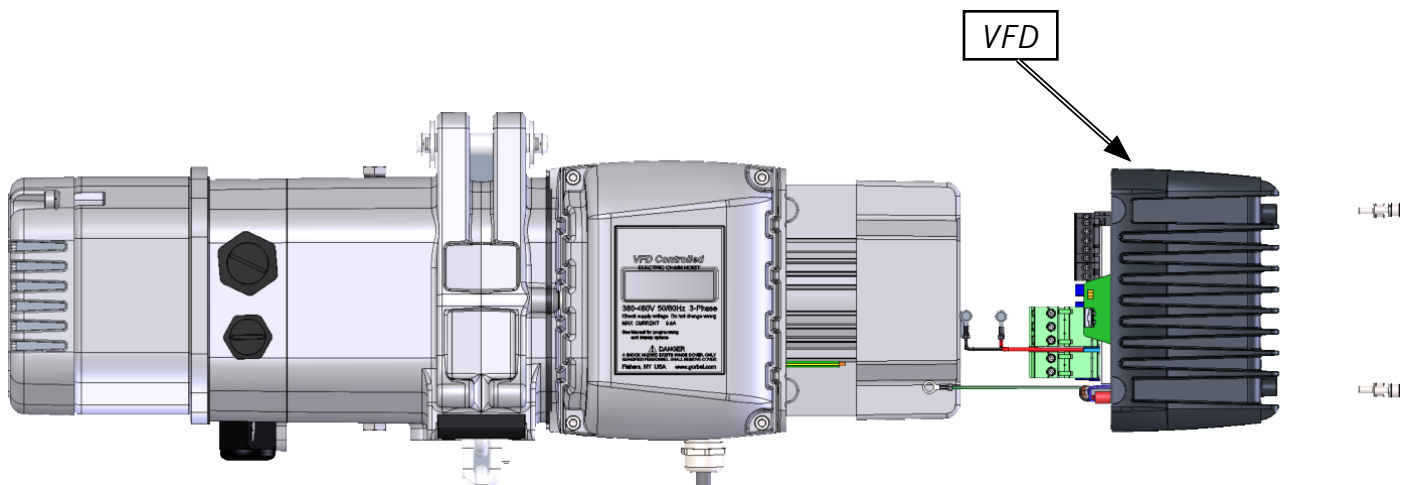

Diagram 2-2. VFD PCB and Connectors.

New Hoist Components Overview, continued

User Interface

The User Interface (UI) is used for various control, programming and diagnostic functions. It is located under an IP55 cover, as shown in **Diagram 2-3**.

For programming procedures, refer to [Setting Operational Parameters with the User Interface \(UI\)](#). The UI is connected to the VFD through a .5 meter (approximately 20 inch) Cat 5 cable that is wrapped around the UI mounting bracket. **A qualified technician** can remove the UI from the hoist and remain operational for programming with the UI Cover off (**Diagram 2-4**), and the hoist energized. This ensures that programming can occur with the cover off.

ELECTRICAL SHOCK HAZARD!



High voltages which could result in serious injury or death and property damage are present when the UI Cover is off. **Only qualified technicians are authorized to power the hoist on with the User Interface Cover removed.**

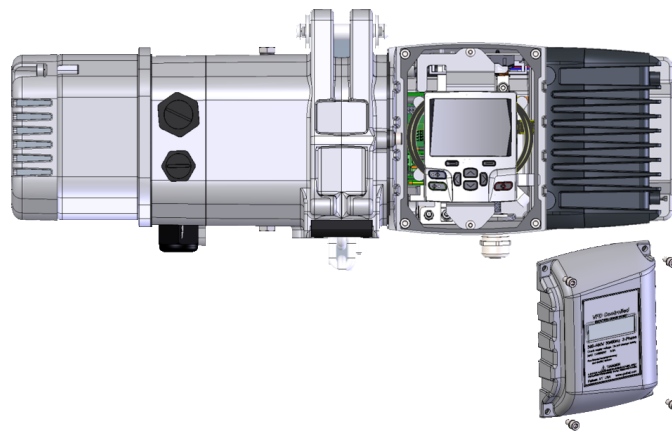

Diagram 2-3 UI and Cover.

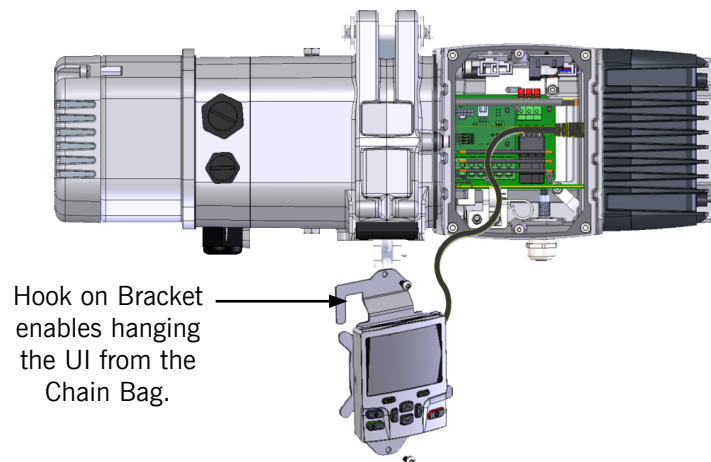

Diagram 2-4: UI and Cat 5 Cable Extended.

Continued on the next page...

New Hoist Components Overview, continued

High Voltage Rectifier and Low Voltage PCBs

ELECTRICAL SHOCK HAZARD!



High voltages which could result in serious injury or death and property damage are present when the UI Cover is off.



There are two PCBs located below the UI that distribute high and low voltages to the hoist (**Diagram 2-5**).

The lower of the two boards is the High Voltage Rectifier PCB. The Low Voltage PCB plugs into the High Voltage Rectifier PCB.

High Voltage Rectifier PCB

The High Voltage Rectifier PCB distributes incoming main power to the VFD and back out to the Hoist AC Motor and contains the rectifier for 205 VDC Brake voltage. It also contains redundant switches that activate the brake.

Low Voltage Control PCB

The Low Voltage Control PCB is a signal distribution board for the hoist. It provides fuse protection for the 24 VDC system control voltage.

It is connected to the Pendant Interface PCB on the brake side of the hoist, and routes signals from the Pendant to the VFD. The Limit Switches are also routed through the Low Voltage Control PCB to the VFD, as are the Motor Thermal Switches.

There are two status LEDs on the Low Voltage PCB:

- The STO STATUS LED will be lit when the E-Stop is disengaged, and extinguished when the E-Stop is engaged.
- The THERM Status LED will be lit in normal operation, and will extinguish when a thermal fault is detected.

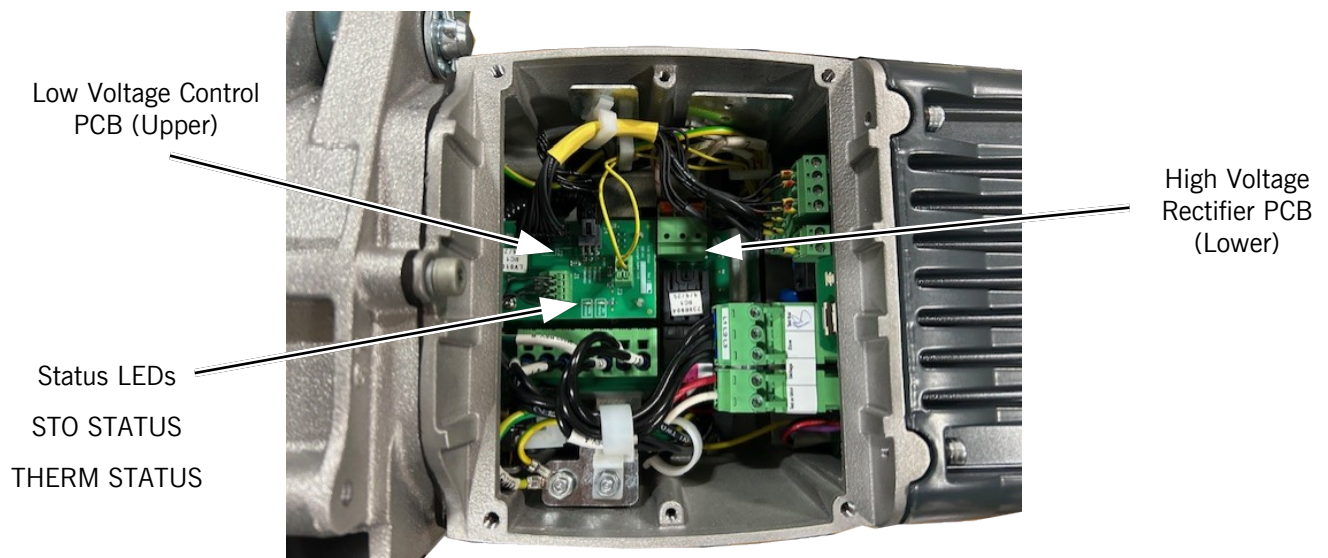

Diagram 2-5. High Voltage Rectifier and Low Voltage PCBs.

New Hoist Components Overview, continued

Brake Side Components

HEAT HAZARD!



There is sufficient heat generated by the Braking Resistors to cause burns. Be sure to wait for 10 minutes after power down before removing the Braking Resistor Cap, or opening the Brake compartment.



Refer to **Diagram 2-6, Side View and End View**.

Two **Braking Resistors** dissipate energy generated by the motor when lowering the load. They are sandwiched between two aluminum plates located at the end of the hoist under an aluminum **Braking Resistor Cap** (not shown). The cap is constructed of vented aluminum, and assists in dissipating the heat that is also generated. The braking resistors and their wiring under the vented aluminum cover are IP55 rated.

The **Pendant Interface PCB** routes signals from Resistor Thermal Switch and the Pendant to the Low Voltage Control PCB, which will route the signals to the VFD. It also provides power to the **Brake** and **Braking Resistors** from the **High Voltage Rectifier PCB** and **VFD**.

The **Clutch** and **Brake** are the same configurations as are present in the previous GS Hoist models. All procedures for operation and maintenance are the same.

Like other GS hoists, when the hoist is not lifting or lowering, the brake is on. This will ensure that there is no slippage when the load is idle. Even if the clutch is worn, the brake will hold the load. **NOTE: It is a best practice not to leave a suspended load unattended.**

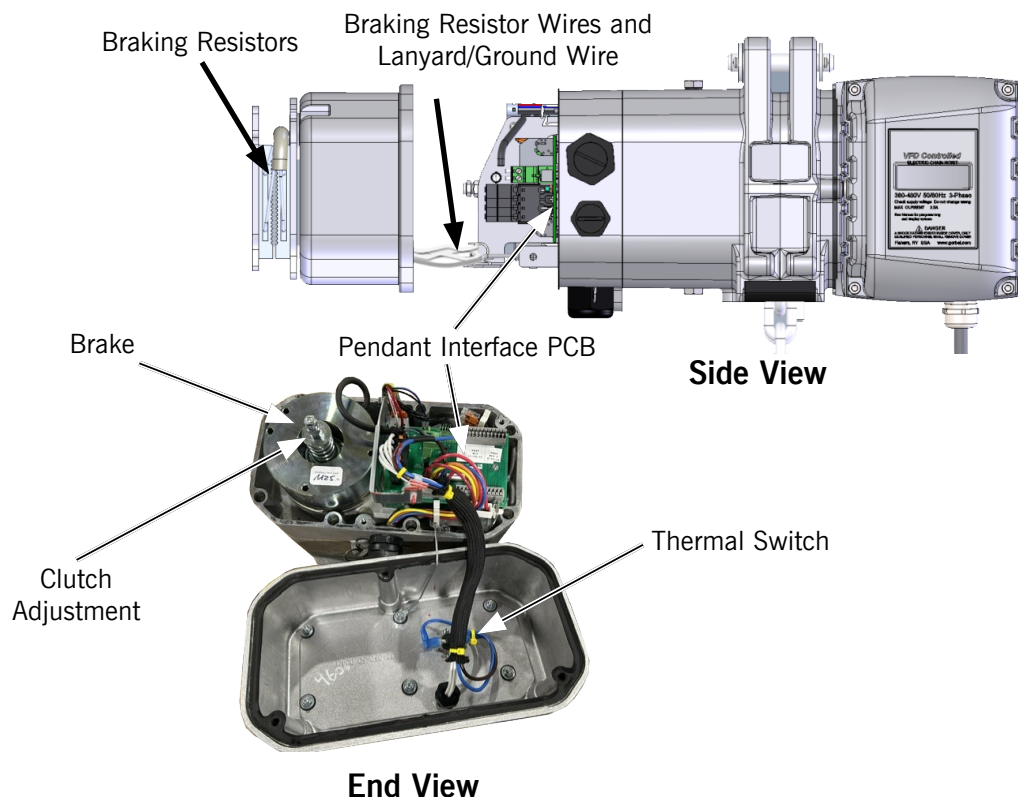

Diagram 2-6. Brake Compartment Components.

New Hoist Components Overview, continued

Conductix Pendant and Speed Settings

The lifting speed of the hoist is controlled with a Conductix pendant (P/N 06682) with a dual-speed Up button and a dual-speed Down button (**Diagram 2-7**).



Diagram 2-7. Conductix Pendant.

The speeds are adjustable, depending on the frequency applied. The set points for the 1/2, 1-Ton and 2-Ton hoists are as shown in **Table 2-2**.

Hoist Capacity	Detent 1 Frequency and Speed (Min/Max)	Detent 2 Frequency and Speed (Min/Max)
1/2 Ton (1 Fall)	10-35 Hz - 4-14 ft/min	35-60 Hz - 14-24 ft/min
1-Ton (1 Fall)	10-35 Hz - 4-14 ft/min	35-60 Hz - 14-24 ft/min
2-Ton (2 Fall)	15-38 Hz - 3-7.5 ft/min	38-60 Hz - 7.5-12 ft/min

Table 2-2. Hoist Speeds.

The Up and Down buttons each have two positions, and the speeds for these positions can be programmed using the UI:

- A. Parameter **Pr.00.001** is used to set **Speed 1** in Up and Down directions and **Pr.00.002** sets **Speed 2** in Up and Down directions.
- B. **Pr.00.003** is used to calculate the **Acceleration Rate** between **Stop** and **Detent 1** in both Control Modes.
- C. The Acceleration Rate between **Stop** and **Detent 1** is $\text{Pr.00.001}/\text{Pr.00.002} \times \text{Pr.00.003}$.
- D. The Ramp Speed from **Speed 1** and **Speed 2** in 2-Speed Control Mode only is $1 - (\text{Pr.00.001}/\text{Pr.00.002}) \times \text{Pr.00.003}$.
- E. Pr. 00.004 sets the Ramp Rate between **Detent 1** and **Detent 2** in the 2-Step Infinitely Variable Control Mode only.

See [Setting Operational Parameters with the User Interface \(UI\)](#) for more information on programming speeds using the UI.

2-Speed Control Mode - Refer to **Diagram 2-8**. In this mode, pressing Up or Down to **Detent 1** will achieve **Speed 1** at an acceleration rate described in item C. Pressing Up or Down to **Detent 2** will achieve **Speed 2** at an acceleration rate described in item D.

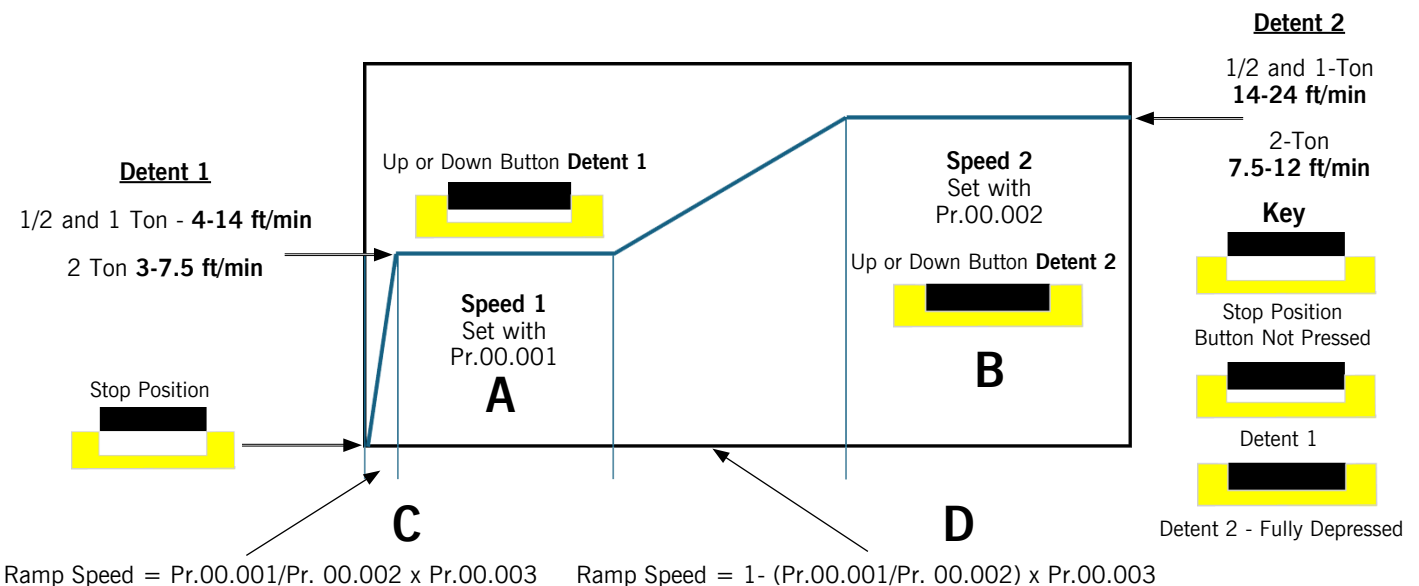

Diagram 2-8. 2-Speed Control Mode Ramps.

New Hoist Components Overview, continued

Conductix Pendant and Speed Settings, Continued

Refer to **Diagram 2-9**, which illustrates the 2-Step Infinitely Variable Control Mode. In this Control Mode:

- A. Pressing Up or Down to **Detent 1** will ramp to **Speed 1** at a rate of **Pr.00.001/Pr.00.002 x Pr.00.003**.
- B. When the Pendant Up or Down button is pressed to the **Detent 2** position, the Hoist speed will begin ramping at the rate set in **Pr.00.004**. Continuing to hold the Up or Down Button in the Detent 2 position will continue to ramp the speed to maximum.
- C. If an Up or Down speed is desired within the infinitely variable ramp, the Pendant switch is moved from **Detent 2 position to Detent 1 position, which will cause the speed to maintain at the desired speed.**
- D. Releasing the Up or Down button at any point in travel will stop the hook.

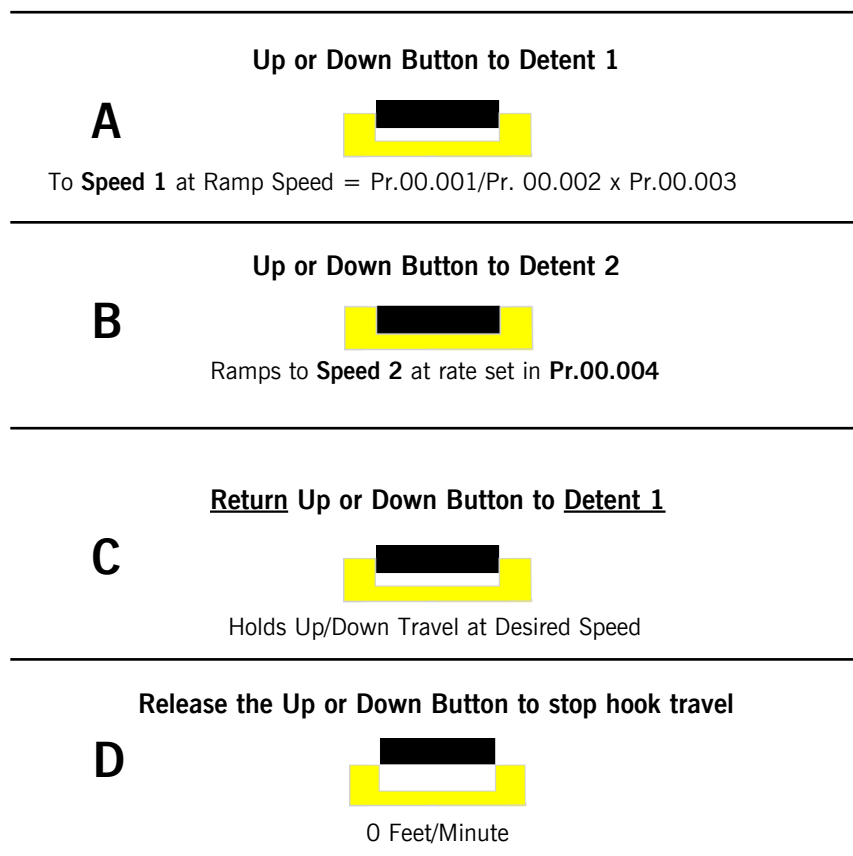

Diagram 2-9. 2-Step Infinitely Variable Control Switch Positions.

Technical Specifications

460V GS VFD Hoist				
Part Number		95500	95501	95502
Max Capacity	lb [kg]	1000 [454]	2000 [907]	4000 [1814]
Max Lift Speed	ft/min [m/min]	24 [7.3]		12 [3.7]
Min Lift Speed	ft/min [m/min]	4 [1.2]		3 [0.9]
Accel Time to 60 Hz	sec	1-10		
Number of Falls		1		2
Max Lift Stroke	ft [m]	40 [12]		20 [6]
Max Lift Range	ft [m]	78 [23.8]		39 [11.9]
Primary Voltage	VAC	480 VAC +/- 10%		
Full Load Current	Amps	1.6	2.6	2.7
Recommended Fuse Size (Class CC)	Amps	6		
Duty Cycle		H4		
Control Voltage		24 VDV @ 0.2A		
Lifting Media		Chain, 7.2 x 21 mm		
Operating Temperature	F [C]	3-104° [-16-40°]		
Operating Humidity Range (Non-condensing)		Up to 85%		
Environmental Rating		IP55		
UL/CSA Certified		No		
CE Certified		No		

Table 2-3. 460V Hoist Technical Specifications.

230V GS VFD Hoist - <u>Differences</u>				
Part Number		95503	95504	95505
Max Capacity	lb [kg]	1000 [454]	2000 [907]	4000 [1814]
Primary Voltage	VAC	230 VAC +/- 10%		
Full Load Current	Amps	3.1	6.1	5.7
Recommended Fuse Size (Class CC)	Amps	15		

Table 2-4. 230 V Hoist Technical Specification **Differences**.

Technical Information

Hoist Components

Diagram 2-10 and 2-11 below illustrate the components of the GS VFD Hoist.

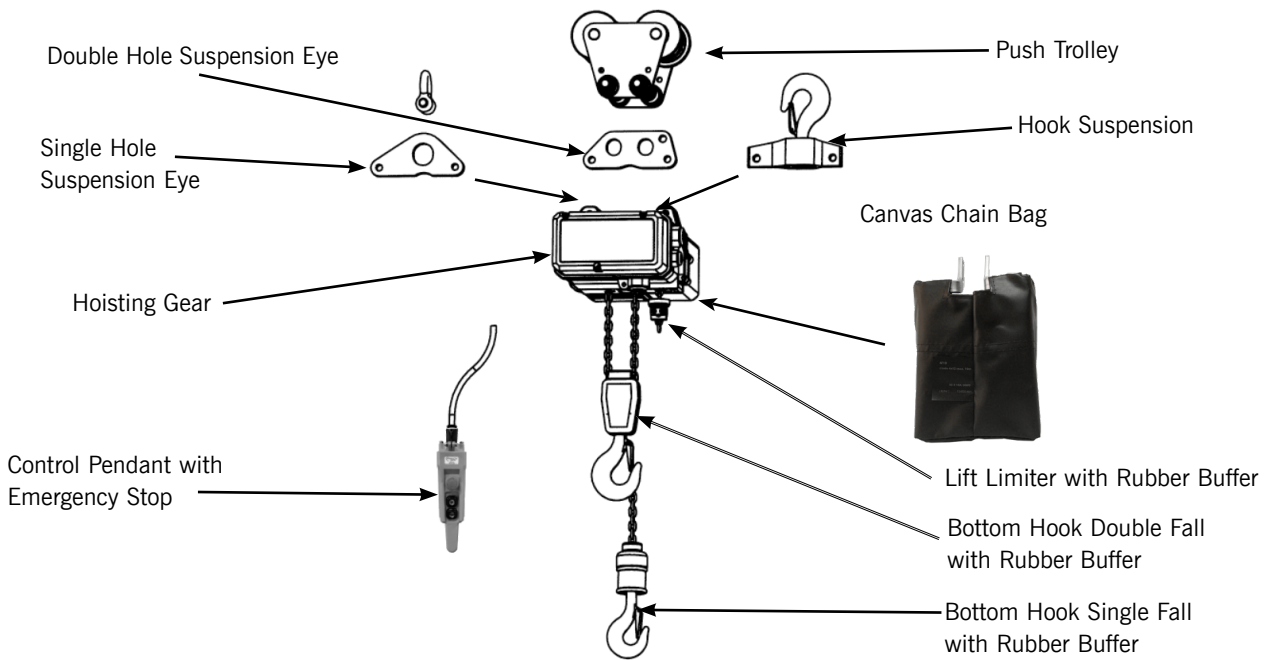

Diagram 2-10. Hoist Components, Part 1.

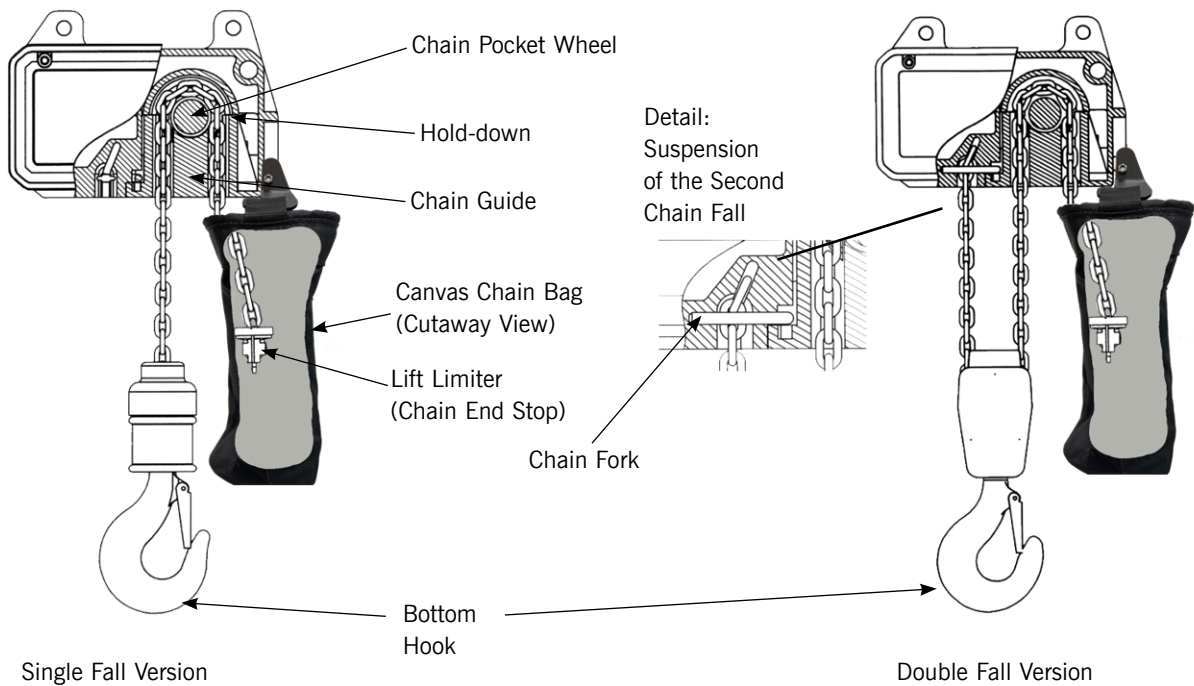

Diagram 2-11. Hoist Components, Part 2.

Technical Information, Continued

User Interface Cover Label

Diagram 2-12 below illustrates the label on the User Interface Cover that shows the input voltage and phase, and max current for the hoist.



Diagram 2-12. Chain Hoist User Interface Cover Label.

Operating Conditions

- Temperature range **3°F to +104°F (-16°C to +40°C)**
- Humidity **85% or less**
- Operating height up to **3300 ft (1000 m) above sea level**
- Insulation class **F**
- Protection class **IP55**
- Duty cycle rating **H4**

CAUTION!



If your operating conditions fall outside of the ranges listed here, please contact Gorbel to ensure your hoist can be used without causing damage to the hoist or creating an unsafe situation for the hoist operator.



Technical Information, Continued

Hoist Dimensions

Diagram 2-13 below illustrates the dimensions of the GS VFD Hoist.

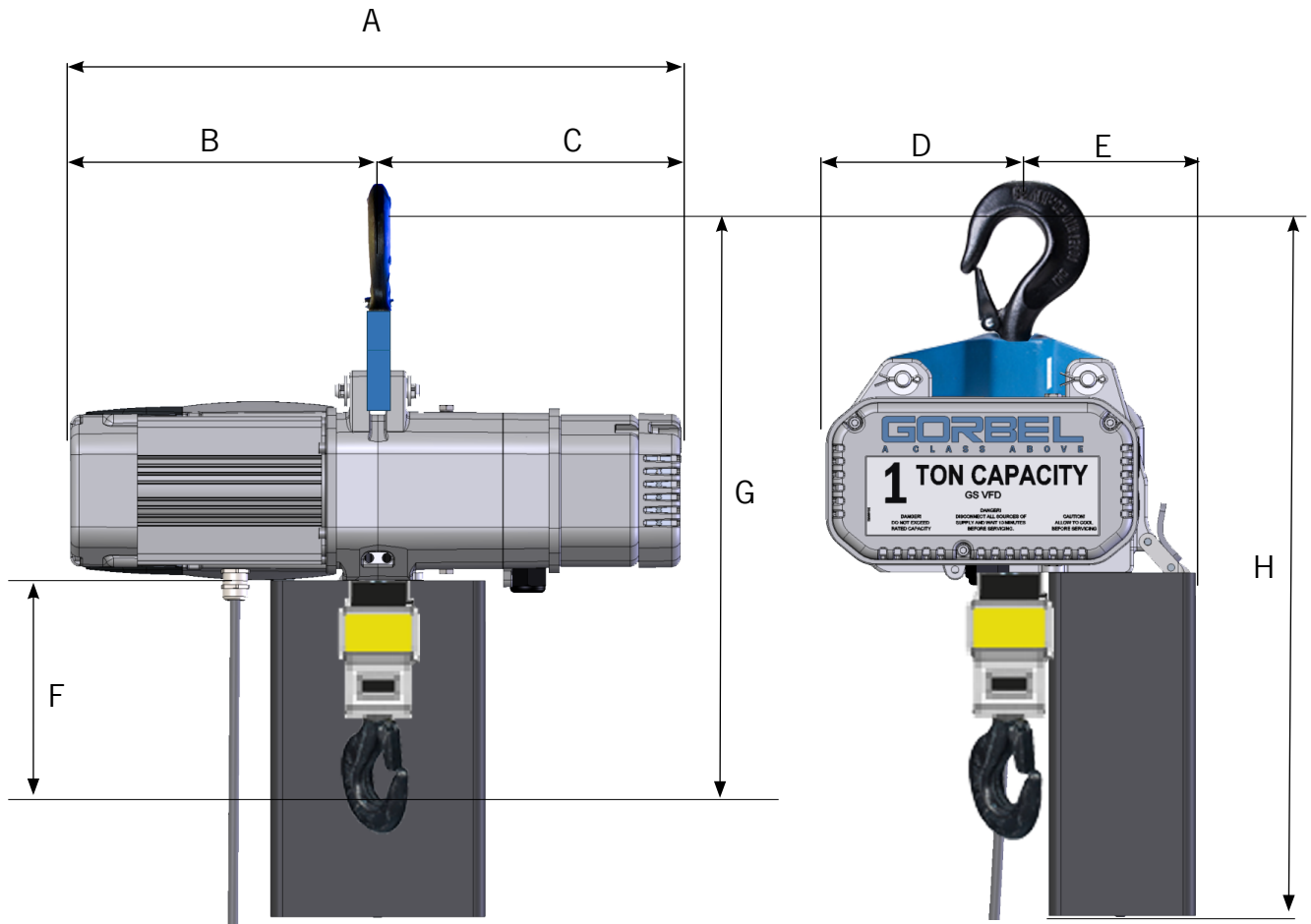

Diagram 2-13. Hoist Measurement Points.

Gorbel Hoist Type	Chain Dimension (mm x mm)	A in (mm)	B in (mm)	C in (mm)	D in (mm)	E in (mm)	F in (mm)	G in (mm)	H in (mm)
070	7.2 x 21	21 7/16 (344.49)	10 13/16 (274.64)	10 5/8 (269.86)	6 5/16 (160.34)	7 3/4 (196.85)	7 7/16 (188.91)	19 11/16 (500.06)	25 7/16 (646.11)

Table 2-5. Hoist Dimensions.

This page intentionally left blank.

Section 3 - Delivery, Transportation and Storage

WARNING!



Read all instructions first before installing or operating equipment.



WARNING!



Do not lift loads of more than 35 pounds (15 kilograms) without a lift assist.



Delivery

The chain hoist, the trolley and the accessories are all packed in heavy-duty corrugated packaging. Some parts can be delivered in foam. After removal of the packaging, dispose of all packaging material safely and in accordance with applicable laws.

Check after delivery:

- For completeness of goods and documentation
- For visible transport damage.

Transport

WARNING!



Do not transport goods on damaged pallets.



WARNING!



Do not transport hoist or hoist components if boxes or internal packing material is damaged or missing.



CAUTION!



Do not expose the hoist to rain or high humidity.



Storage Conditions

- Store indoors for up to 2 years, then powering up for a minimum of 1 hour. This enables the hoist to be stored for another 2 years.
- Temperature range 5°F (-15°C) to +131°F (55°C)
- Humidity 85% or less
- No swings in temperature that would cause condensation
- No corrosive environment
- Do not expose to direct sunlight

This page intentionally left blank.

Section 4 - Installation

WARNING!



The installation is to be performed by properly trained and authorized personnel only!



Installer Qualifications

- The worker/operator should be familiar with the hoist, hoist controls and installation/assembly procedures before being authorized to install or operate the hoist or lifting system.
- The worker/operator shall be required to read this manual, the warnings, instructions and warning labels before starting installation or operation of the hoist.
- The worker/operator shall obey all national or federal health and safety regulations during installation work and operation.
- The worker/operator shall be trained in proper rigging procedures for the attachment of loads to the hoist's load hook.
- The worker/operator shall be trained to be aware of potential malfunctions of the equipment that require adjustment or repair, and to be instructed to stop operation if such malfunctions occur, and to immediately advise their supervisor to take corrective action.
- The worker/operator shall have normal depth perception, field of vision, reaction time, manual dexterity and coordination.
- The worker/operator must **not** have a history of, or be prone to, seizures, loss of physical control, physical defects or emotional instability that could result in actions of the operator being a hazard to the operator or others.
- The worker/operator must **not** operate a hoist or lifting system when under the influence of alcohol, drugs or medication.

General

WARNING!



Overhead hoists are intended for vertical lifting of freely suspended, unguided loads only. Do not use the hoist for loads that are not lifted vertically, loads that are not freely suspended or loads that are guided.



WARNING!



Do not stand or walk under and suspended load.



Prior to installing the hoist, the installer must ensure that the power supply is shut off and securely locked and properly tagged.

Unpacking the Hoist

WARNING!



Wear appropriate personal safety and protection equipment in accordance with OSHA regulations. Obey special requirements of the installation safety equipment. For example, wear eye protection glasses, protective shoes, gloves, helmet, harness.



1. Place the package with the hoist and accessories on stable ground or a mounting pad.
2. Place this manual near you so you can use it as a reference during installation.
3. Follow all written instructions.
4. Unpack the hoist and other component parts and place them safely on the work surface.
5. Gather the following tools:
 - Set of screwdrivers
 - Set of socket head wrenches (metric)
 - Pliers/Multi-grip pliers
 - Torque wrench (20 ft./lbs. to 420 ft./lbs.)
 - Tape/ruler
6. Refer to **Diagram 4-1**. The package of the chain hoist contains the following parts:
 - A. Chain hoist with assembled Chain, Bottom Hook and Lift Limiter (1 or 2 fall)
 - B. Canvas Chain Bag with fastening screw (metric dimensions)
 - C. Fastening bolts with washers and split pins
 - D. Either single Suspension Eye or Hook Suspension.

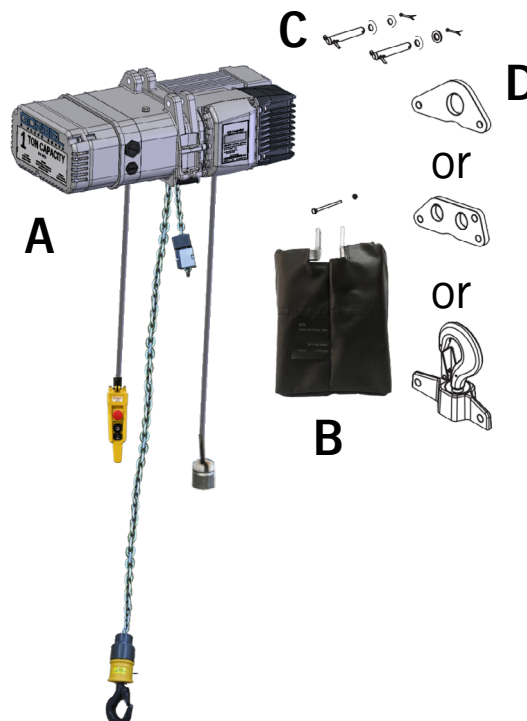

Diagram 4-1. Chain Hoist Components.

Unpacking the Hoist, Continued

Refer to **Diagram 4-2**. The push trolley packaging contains the following parts:

- A. Two Side Plates.
- B. Set of suspension bolts with Nylock or counter nuts (metric dimensions), washers, spacers, distance tubes.
- C. Assembly instructions.

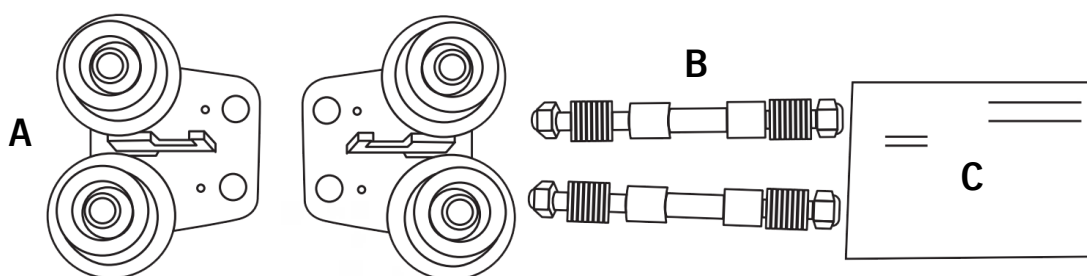

Diagram 4-2. Push Trolley Components.

Inspection Before Assembly

1. Check for visible damage.
2. Check packing list/order confirmation for complete delivery.
3. Check that the load capacities on the Hoist Type Plate and on the load hook match.

CAUTION!



Do not begin assembly until all parts have been located. Use only original parts from the manufacturer.



WARNING!



Prior to installation, ensure that the suspension and the supporting structure are adequate to support the chain hoist and loads. If necessary, consult a professional qualified to evaluate the suspension location and its supporting structure.



Assembly

Assembly with Single Hole Suspension Plate

CAUTION!



The single hole suspension eye must be inserted into the suspension holes on the electric chain hoist and pinned into place with the two bolts. Use washers with the bolts and secure position with correctly bent split pins.



WARNING!



On the suspension eye are two symbols: a single fall symbol and a double fall symbol. For a hoist configured for single fall, the single fall symbol has to be on the chain bag side of the hoist. For a double fall hoist, the double fall symbol on the suspension eye has to be on the bag side of the hoist body.



1. Refer to **Diagram 4-3**. Orient the plate as shown for either single or double fall hoists.
2. Attach the Suspension Plate to the hoist with bolts, washers and Cotter pins.

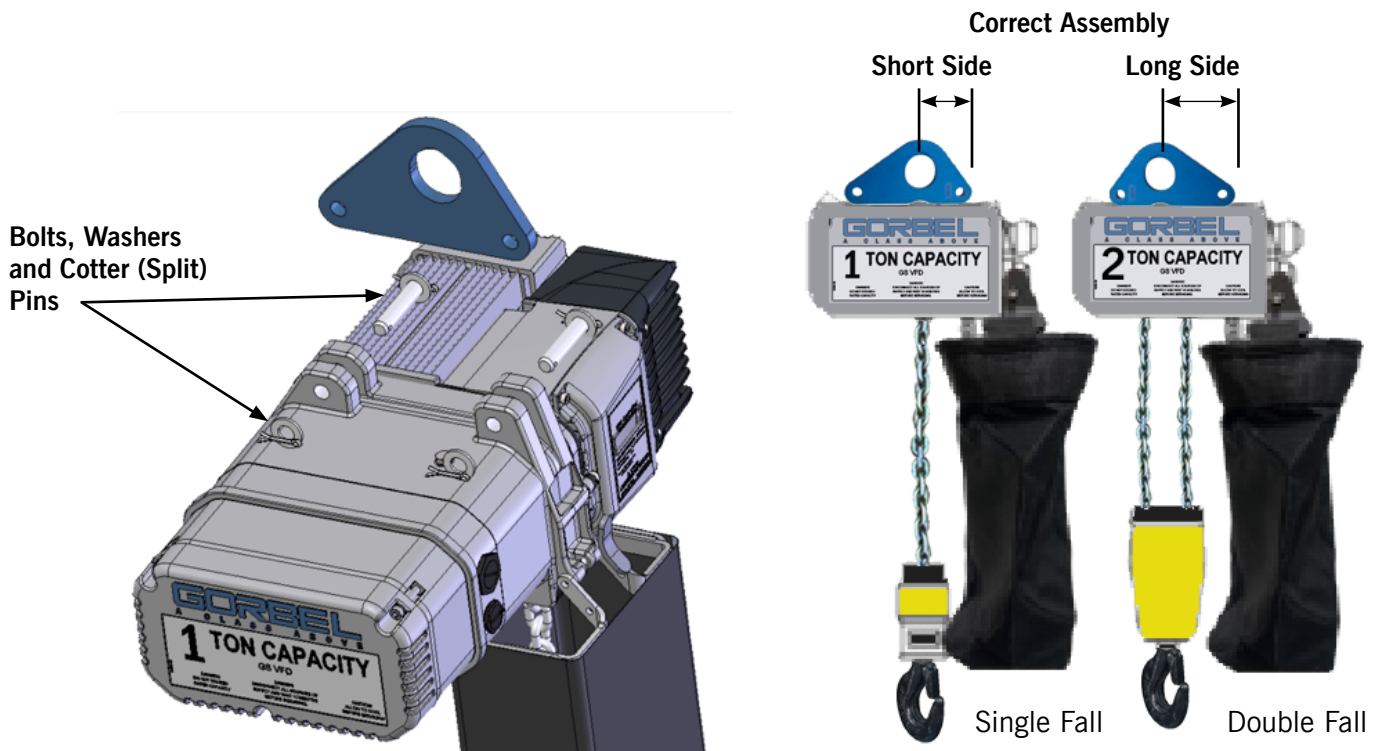

Diagram 4-3: Single and Double Fall Symbols on Single Hole Suspension Plate.

Assembly with Double Hole Suspension Plate

CAUTION!



The suspension eye must be inserted into the suspension holes on the electric chain hoist and pinned into place with the two bolts. Use washers with the bolts and secure position with two split pins.



WARNING!



The hole for the tandem trolley on the double hole suspension eye must be on the chain bag side.



1. Refer to **Diagram 4-4**. Locate the hole on the Double Hole Suspension Plate that indicates the orientation of the plate.
2. Attach the Suspension Plate to the hoist with bolts, washers and Cotter pins..

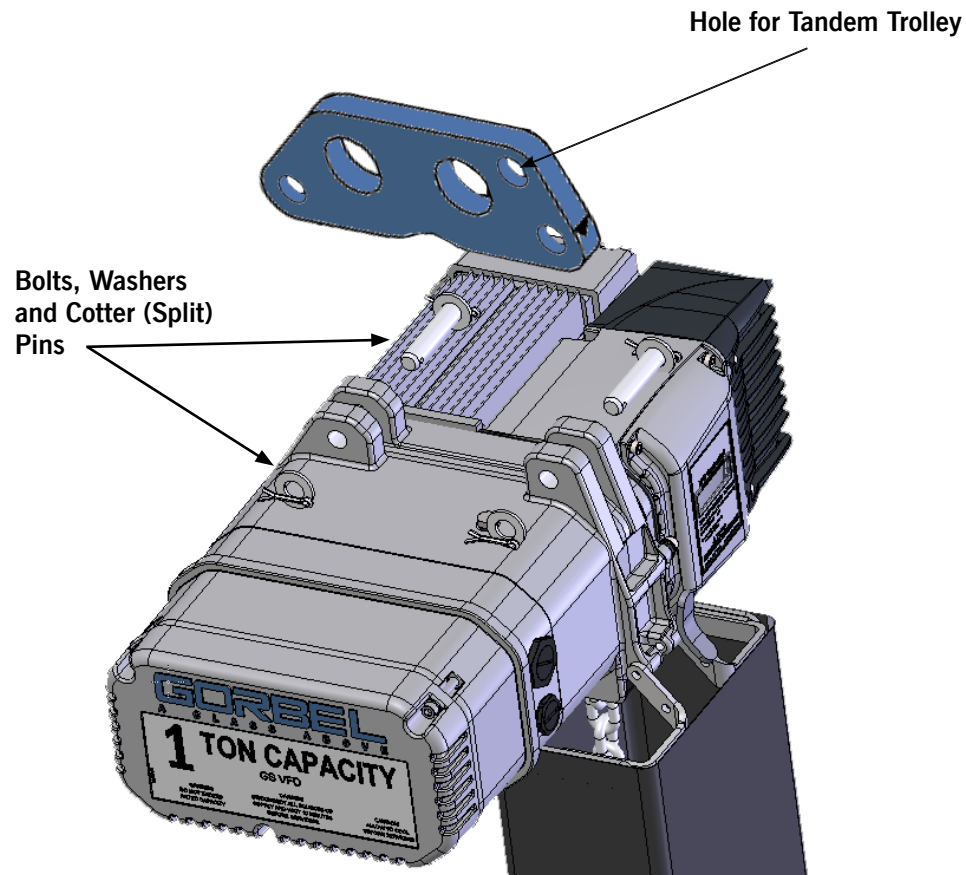

Diagram 4-4: Double Hole Suspension Plate.

Assembly with Rigid Hook Suspension

CAUTION!



The rigid hook must be pinned with two bolts to the suspension holes on the chain hoist and secured with washers and correctly bent split pins.



WARNING!



On the hook suspension are two symbols: a single fall symbol and a double fall symbol. For a hoist configured for single fall, the single fall symbol has to be on the chain bag side of the hoist. For a double fall hoist, the double fall symbol on the hook suspension has to be on the chain bag side of the hoist.



1. Refer to **Diagram 4-5**. Locate the sticker on the Rigid Hook that indicates the orientation of the hook.
2. Attach the Rigid Hook to the hoist.

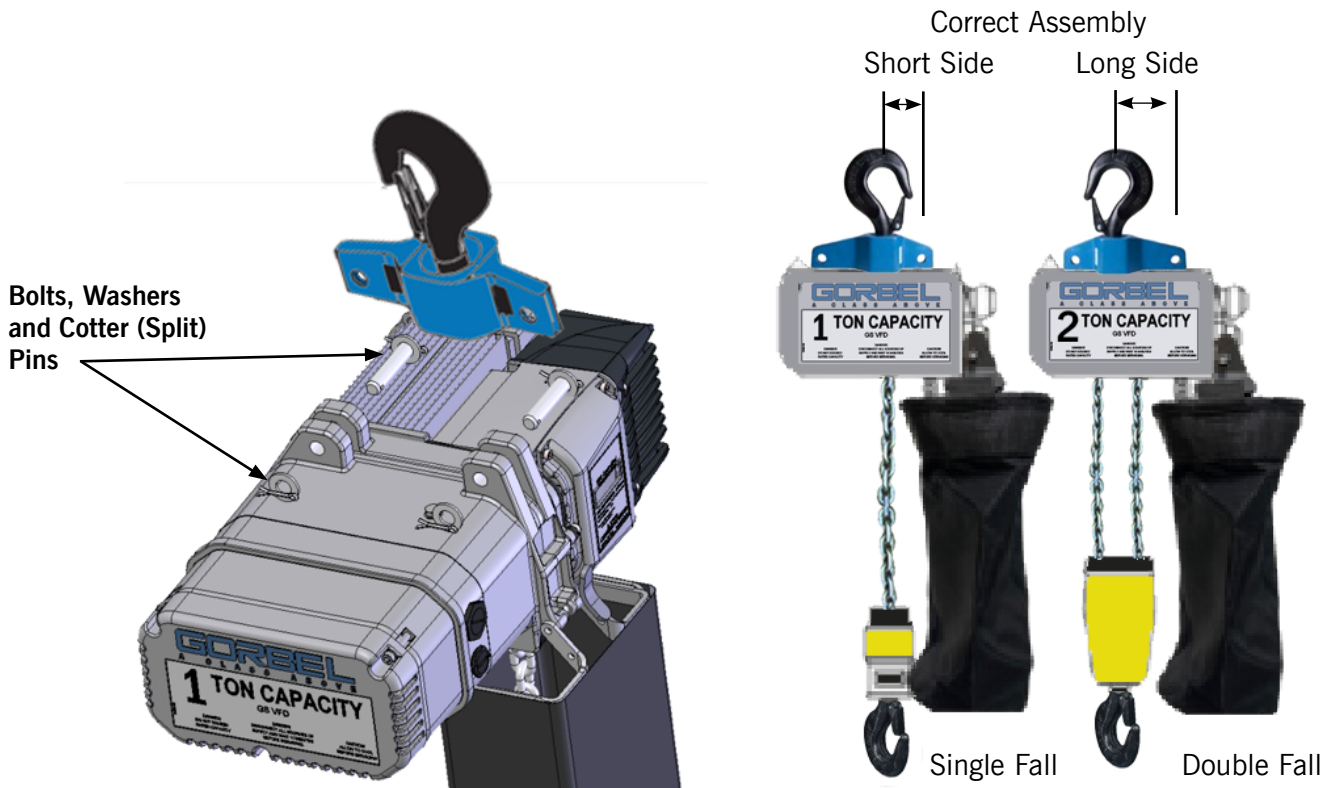

Diagram 4-5. Rigid Hook Orientation for Single and Double Fall.

Vent Screw**CAUTION!**

The vent screw should be tightened only 1/4 turn past finger tight.



Refer to **Diagram 4-6**. After completion of hoist assembly, remove the plug and install the vent screw. Vent screw installation must be completed before hoist is put into operation.

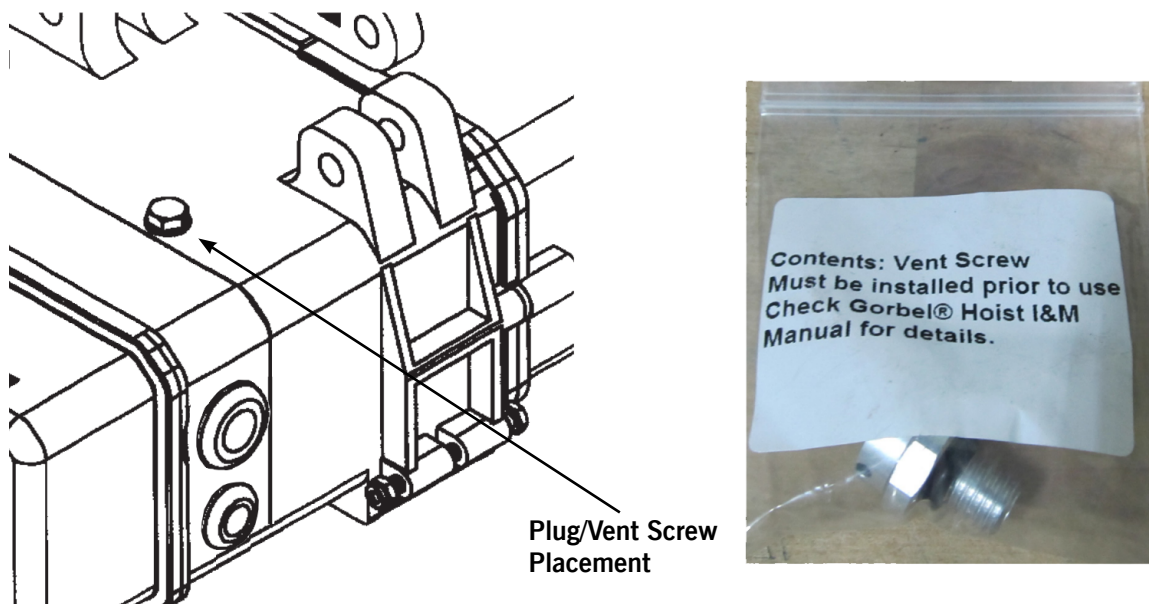

Diagram 4-6. Plug and Vent Screw Placement.

Canvas Chain Bag

The GS VFD Hoist comes with a canvas chain bag. All chain containers are marked with the chain diameter and the maximum quantity of chain accommodated.

Example: 7/18 means chain diameter 7.2 millimeters and maximum length of 18 meters (59 feet).

WARNING!

Double check the chain length on the hoist with the maximum accommodation length marked on the chain bag. Consider that for double fall hoists the chain length is twice the lifting height.

Do not continue if you discover a longer chain on the hoist than is marked on the chain bag.

Do not overload the chain container. It can damage the hoist and cause serious accidents.



Mounting the Canvas Chain Bag

WARNING!



Danger of serious injuries for hands and fingers!
Keep hand and fingers away from the running chain.
Use the Nylock Nut only once.



1. Refer to **Diagram 4-7**. Insert the chain end with lift limiter, its rubber bumper and spring actuator (if scope of supply) loosely into the chain container.
2. Assemble the chain container onto the chain hoist with screw and secure with nylock nut.
3. Feed the chain into the canvas chain container by means of the lifting motor, press 'UP' button.

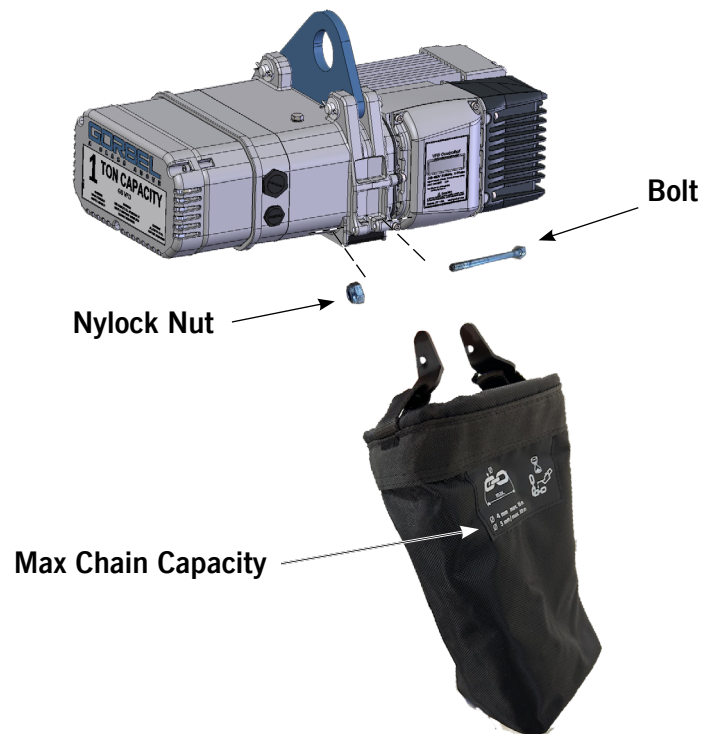

Diagram 4-7. Canvas Chain Bag Placement.

Connecting Electrical Power

CAUTION!



The hoist must be connected only to a power source that complies with electrical codes for its input voltage rating.



ELECTRICAL SHOCK HAZARD!



Hoist electrical connection must only be conducted by a qualified electrician. Main power must be disconnected from the hoist until it is fully configured and ready for power to be applied.



ELECTRICAL SHOCK HAZARD!



Check that the input voltage complies with that specified on the Type Plate. Connect the power supply cable in accordance with wiring diagram. Depending on festoon length, we recommend a minimum 14 AWG 4 conductor cable. Your application may require 12 or 10 gauge.



WARNING!



Do not use the hoist when the direction of lift does not comply with the symbols on the control pendant. Under the conditions, the electric limit switches will not be working.



Refer to **Diagram 4-8**. Power connection to the hoist may be hard-wired to building power, or can be connected through a Twist-Lock plug.



Diagram 4-8. Plugging in the Hoist.

Limit Switches

Refer to **Diagram 4-9**. For the proper function of the limit switches, the up/down directions at the pendant must correspond to the moving direction of the hook. Check the function of the limit switches for lifting and lowering prior to use.

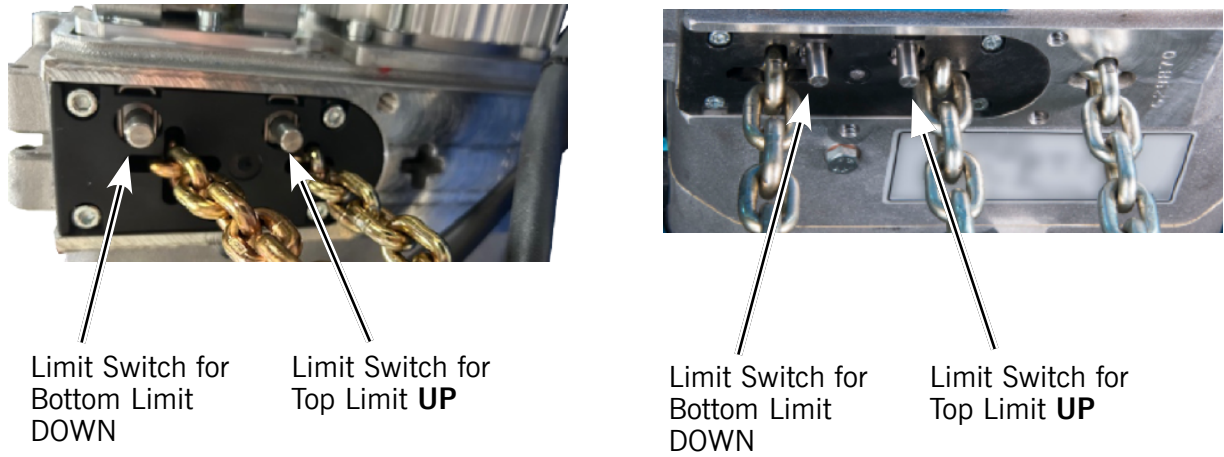

Diagram 4-9. Limit Switches 1 Fall (l) and 2 Fall (r) Hoists.

Trolley

Refer to **Table 4-1** and **Diagram 4-10**. The Gorbel GS VFD Hoist uses only a Push Trolley. There is no power trolley option for this hoist at this time.

Part No.	Standard Flange Width (in)	Part No.	Larger Flange Width, S1 (in)	Part No.	Larger Flange Width, S2 (in)	Capacity (lbs.)	Hoist Type
95162	2.6-5.31	95172	5.39-8.46	95182	8.66-11.81	4000	070/071

Table 4-1. Trolley Specifications.

CAUTION!



For all other beam sizes, inform Gorbel and the correct Push Trolley will be made available.



Push Trolley with two connecting bolts for Double Hole Suspension Eye.

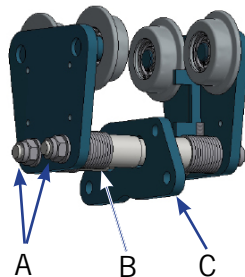

- A. Suspension Bolts
- B. Spacing Washers
- C. Suspension Eye

Diagram 4-10: Push Trolley Components.

Trolley Assembly

Refer to **Diagram 4-11, Steps 1-6**. Perform the following steps to assemble the Trolley:

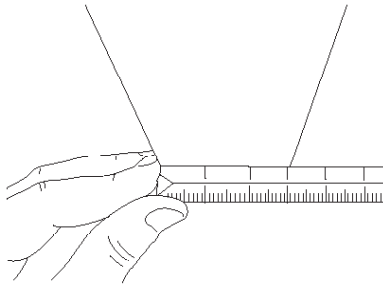

Step 1: Measure Beam Width.

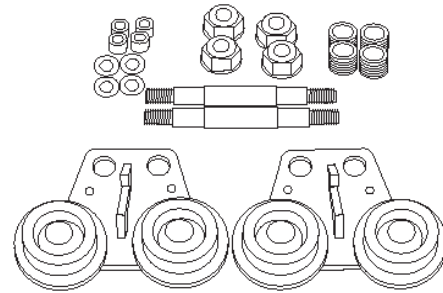

Step 2: Prepare Parts for Assembly.

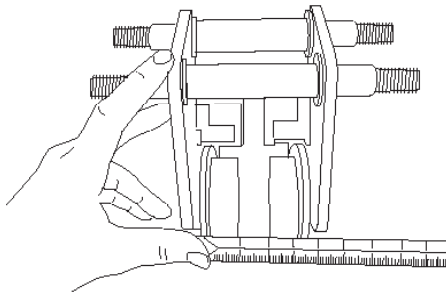

Step 3: Determine quantity of washers.
Note: Washers must be used symmetrically.

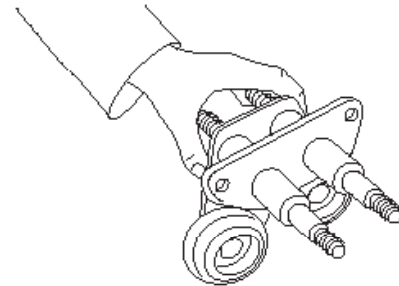

Step 4: Assemble one side plate with washers, spacer and suspension plate.

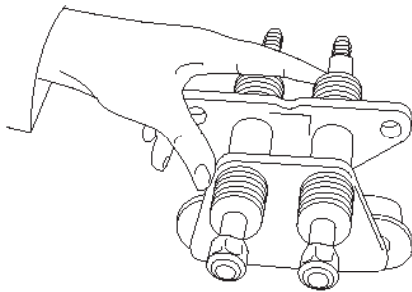

Step 5: Fit Nylock nuts with washers on the side plate.

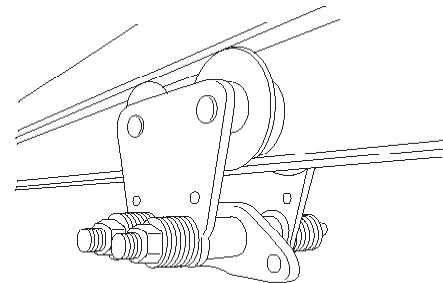

Step 6: Put the trolley together on the beam, allowing 1/16 inch between the running wheel flange and the beam flange. Tighten the nylock nuts.

Diagram 4-11, Steps 1-6: Trolley Assembly.

WARNING!

A clearance of 1/16 inch between the running wheel flange and the beam flange is necessary. The width is adjusted by inserting spacing washers **symmetrically**. The suspension eye is mounted between the spacing bushings on the trolley connecting bolts.



Use original parts only.

Trolley Assembly, Continued

7. Double-check the space between girder flange and trolley wheel (approximately 1/16 inch on each side).
8. Refer to **Table 4-2**. Tighten the nuts of the connecting bolts with a torque wrench only.

Hexagon nuts	Tightening torque in ft/lb. (Nm)
M16x1.5	55 (75)
M22x1.5	110 (150)
M36x1.5	415 (560)

Table 4-2. Trolley Torque Values.

9. Fit the electric chain hoist to the trolley assembly with bolts, washers and split pins.
10. Check the free movement between the trolley and the chain hoist in all directions as shown in **Diagram 4-12**.

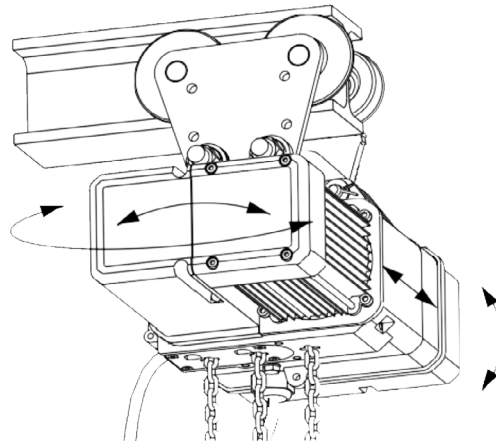
**Diagram 4-12.** Testing Hoist Movement on Trolley.**CAUTION!**

Movement in the directions shown by the arrows must still be possible between the hoist and the trolley when assembly is complete.

The type of suspension plate depends on the respective chain hoist type and trolley type (beam flange width).



Section 5 - Operation

WARNING!



Persons intending to operate the hoist must be trained prior to commencing operation.

Refer to Section 1 - [Hoist Safe Operating Practices](#) before operating this hoist.



WARNING!



Improper operation of this hoist can lead to unsafe conditions and **presents a risk of serious property damage, INJURY or DEATH.**



Hoist Operator Qualifications

1. The worker/operator shall be familiar with the hoist, hoist controls and installation/assembly procedures before being authorized to install or operate the hoist or lifting system.
2. The worker/operator shall be required to read this manual, the warnings, instructions and warning labels before starting installation or operation of the hoist.
3. The worker/operator shall obey all national or federal health and safety regulations during installation work and operation.
4. The worker/operator shall be trained in proper rigging procedures for the attachment of loads to the hoist hook.
5. The worker/operator shall be trained to be aware of potential malfunctions of the equipment that require adjustment or repair, and to be instructed to stop operation if such malfunctions occur, and to immediately advise his supervisor to take corrective action.
6. The worker/operator shall have normal depth perception, field of vision, reaction time, manual dexterity and coordination.
7. The worker/operator must **not** have a history of or be prone to seizures, loss of physical control, physical defects or emotional instability that could result in actions of the operator being a hazard to the operator or others.
8. The worker/operator must **not** operate a hoist or lifting system when under the influence of alcohol, drugs or medication.

Hoist Inspection Before Starting Work

WARNING!



Before starting work, inspect the electric chain hoist, trolley, chain and all load bearing components for visual defects.



Daily Inspection and Checks

1. Functional test of brake.
2. Functional test of limit switches.
3. Check that the trolley runway is free from obstructions and that the end stops on the trolley runway are fitted and secured.
4. Inspect the load chain for sufficient lubrication and lubricate if necessary. Refer to [Lubrication](#) in **Section 6**.
5. Visually check the load chain for external defects.

WARNING!



Do not operate a hoist with defects. Ensure all defects are corrected before operating the hoist.



WARNING!



Confirm that the load is properly attached to the hoist and trolley by running a short test cycle. To do this, lift and lower the load several times.



WARNING!



The selection and calculation of the proper suspension point and beam construction for the hoist and trolley are the responsibility of the hoist owner.



Preparing for a Lifting Operation

WARNING!



Always attach the load to the hook saddle. **Never attach the load to the load hook tip, and never attach the hoist by the suspension hook tip.**



WARNING!



Do not remove the hook safety latch. Make sure that the latch is safely closed after suspending the load.



Preparing for a Lifting Operation, Continued

WARNING!



Never use the load chain as a sling chain. Use only approved and certified slings or lashing devices to attach the load.



Attaching the Load

1. Slack the hoist chain a sufficient amount to place the load hook.
2. Attach the load to the load hook saddle, ensuring that the load is not on the hook tip, and that the hook safety latch is fully closed.

Lifting and Lowering the Load

CAUTION!



Do not pull on the hoist control pendant. Push the electric chain hoist, its bottom hook or the suspended load to move a hoist with a push trolley.



1. Lift the load or the bottom hook by operating the 'UP' button.
2. Lower the load or the bottom hook by operating the 'DOWN' button.

NOTE: Refer to [Conductix Pendant and Speed Settings](#) for information on lifting speeds.

CAUTION!



The slow speed must only be used for short hook travel distances. The lift limiter (chain end stop) must not be used as an operational limit switch.



Emergency Stop

The Emergency Stop is a red, mushroom shaped button on the hoist pendant. In the event of a hazardous situation, pushing the Emergency Stop will stop all hoist movement.

WARNING!



Operating the emergency stop does not automatically disconnect the main power to the chain hoist or the trolley. If you activate the Emergency Stop, safely clear the reason for the stop, and then release the Emergency Stop button by rotating in clockwise direction.



Lift Limiter

The lift limiter (chain end stop) will halt the downward movement of the load hook near the end of the chain. For this reason, it must be connected to the idle chain strand.

WARNING!



The lift limiter should be assembled at the third link from the end of the idle chain strand. In cases where the end of the idle chain strand will be fixed to the chain hoist body or chain container frame, the lift limiter must be assembled 20 inches (50 cm) from the end of the idle chain strand.



Limit Switches

The hoist Limit Switches are safety devices and must not be used as operational movement limiters.

Setting Operational Parameters with the User Interface (UI)

The UI provides access to the programmable parameters built into the hoist. With it, the operational parameters including speed points and acceleration profiles can be modified to suit the customer's needs.

Table 5-1 contains the parameters that are either viewable or modifiable by a technician. The adjustable parameters are:

- 00.001 - Sets Speed 1 Up and Down
- 00.002 - Sets Speed 2 Up and Down
- 00.003 - Sets Acceleration Rate Up and Down
- 00.004 - Sets the Ramp Rate between the two set points in the 2-Step Infinitely Variable Control Mode
- 00.005 - Toggles between 2-Step Infinitely Variable and Dual Speed Control
- 00.006 - During maintenance, used to Jog the unit slowly up
- 00.007 - During maintenance, used to Jog the unit slowly down
- 00.013 - Sets the cost per kWh of electrical energy
- 00.015 - Resets energy meters
- 00.063 - Settings for viewing the following on Line 2 of the UI:
 - Output Frequency
 - Output Voltage
 - Output Power
 - Motor (Reference) RPM
 - D.C. Bus Voltage
- 00.065 - Modified when [Performing a User Save](#) operation.
- 00.066 - With 00.065, modified when [Performing a User Save](#) operation.

All other parameters in **Table 5-1** are Read Only. **Table 5-2** contains the two programmable speed parameters for **2-ton Hoists**.

As shown in **Diagram 5-1**, qualified technicians can operate the UI tethered to the hoist with the UI cover off.

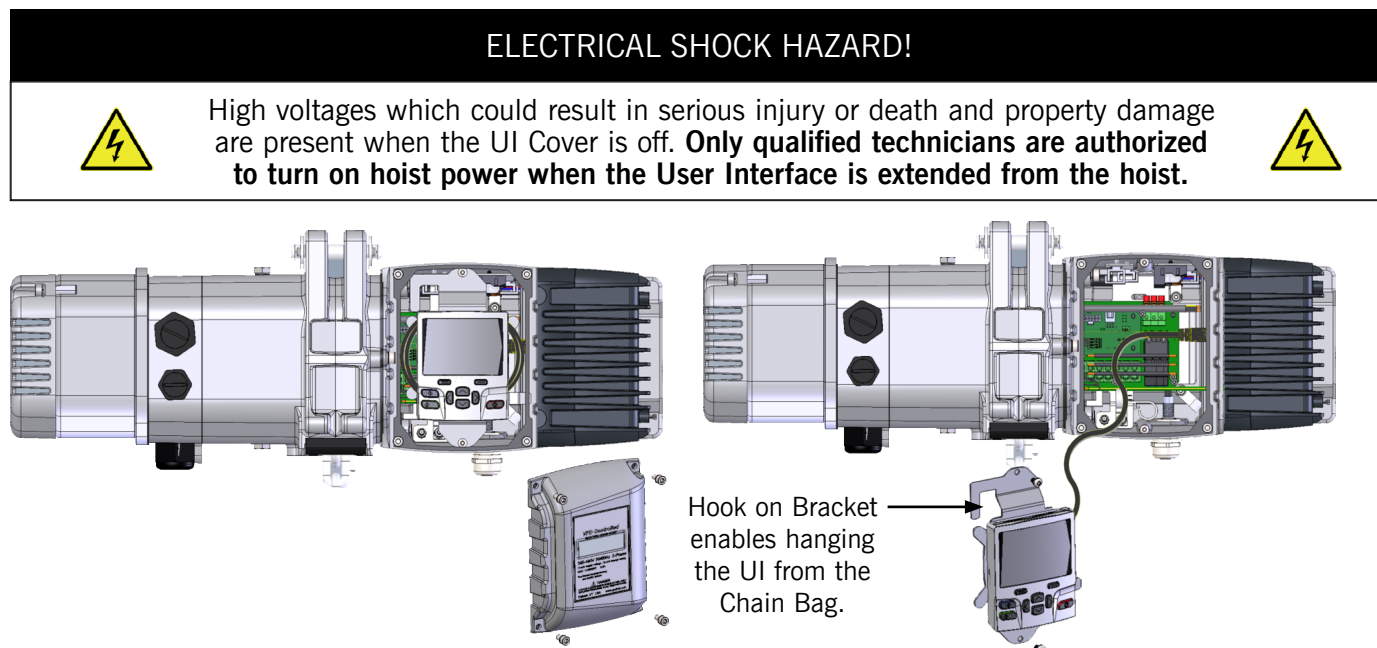

Diagram 5-1: UI and Cat 5 Cable Extended.

Setting Operational Parameters with the User Interface (UI), Continued

UI Features and Functions

The UI Keypad provides access to the features and functions shown in **Diagram 5-2**:

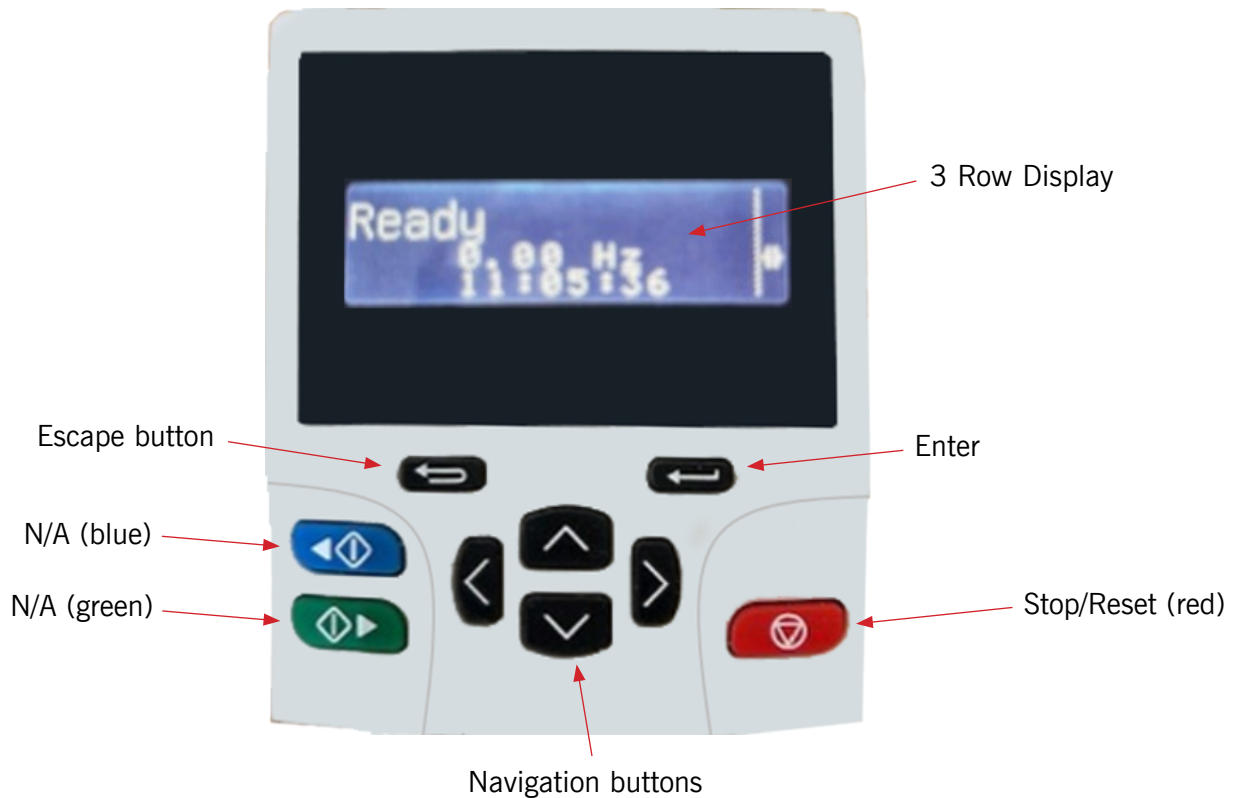

Diagram 5-2: UI Buttons.

The **Keypad** has an LCD screen that can display:

- Hoist Status Home Screen: When the keypad powers up, it displays the Hoist Status.
- Parameter Menu: The display allows users to view all the available Menu 00 parameters in the unit. This is where users will view the status and settings of the unit's parameters including the adjustable ones that change the unit's control mode, preset speed points, and acceleration profiles.
- Parameter Editing: The display allows users to change the values of the writable Menu 00 parameters to optimize the hoist for their lift application.

Hoist Status Home Screen

Upon Startup, the UI will display a startup screen with the name of the Drive and motor type for about 3 seconds, after which the Hoist Status Home Screen appears as seen in **Diagram 5-3**. This is the default for the keypad display and is visible during normal operation.

There are 3 rows of information in the Hoist Status Home Screen:

- **Row 1** – Displays the current hoist status.
 - **Inhibit:** The hoist is inhibited and cannot be run
 - **Ready:** The hoist is ready to run. The hoist enable is active
 - **Stop:** The hoist is stopped / holding zero frequency
 - **Run:** The unit is active and running
 - **Deceleration:** The motor is being decelerated to zero frequency
 - **Various Faults:** See [Troubleshooting Tables](#)
- **Row 2** – This displays the ‘Status Mode Parameter’ (Pr.00.063), which by default is set to display the Output Frequency of the VFD. Parameter (Pr. 00.063) can be changed to any of the read only parameters shown below.
 - **05.001:** Output Frequency (default - shown in **Diagram 5-3**)
 - **05.002:** Output Voltage
 - **05.003:** Output Power
 - **05.004:** Motor (Reference) RPM
 - **05.005:** D.C. Bus Voltage
- **Row 3** – This displays the accumulated run time of the of the unit in the ‘Hours’ : ‘Minutes’ : ‘Seconds’ format.



Diagram 5-3: 3-Row Display Contents.

Parameter Menu Navigation

If a **Navigation button** or the **Enter button** is pressed while in the Hoist Status Home Screen, the keypad will open the Parameter Menu. This allows access to view the setting/state of all the parameters in Menu 00.

When in parameter menu, use the Up/Down buttons to navigate between the parameters as seen in **Diagram 5-4**. To modify parameters, refer to [Hoist Parameter Editing](#).

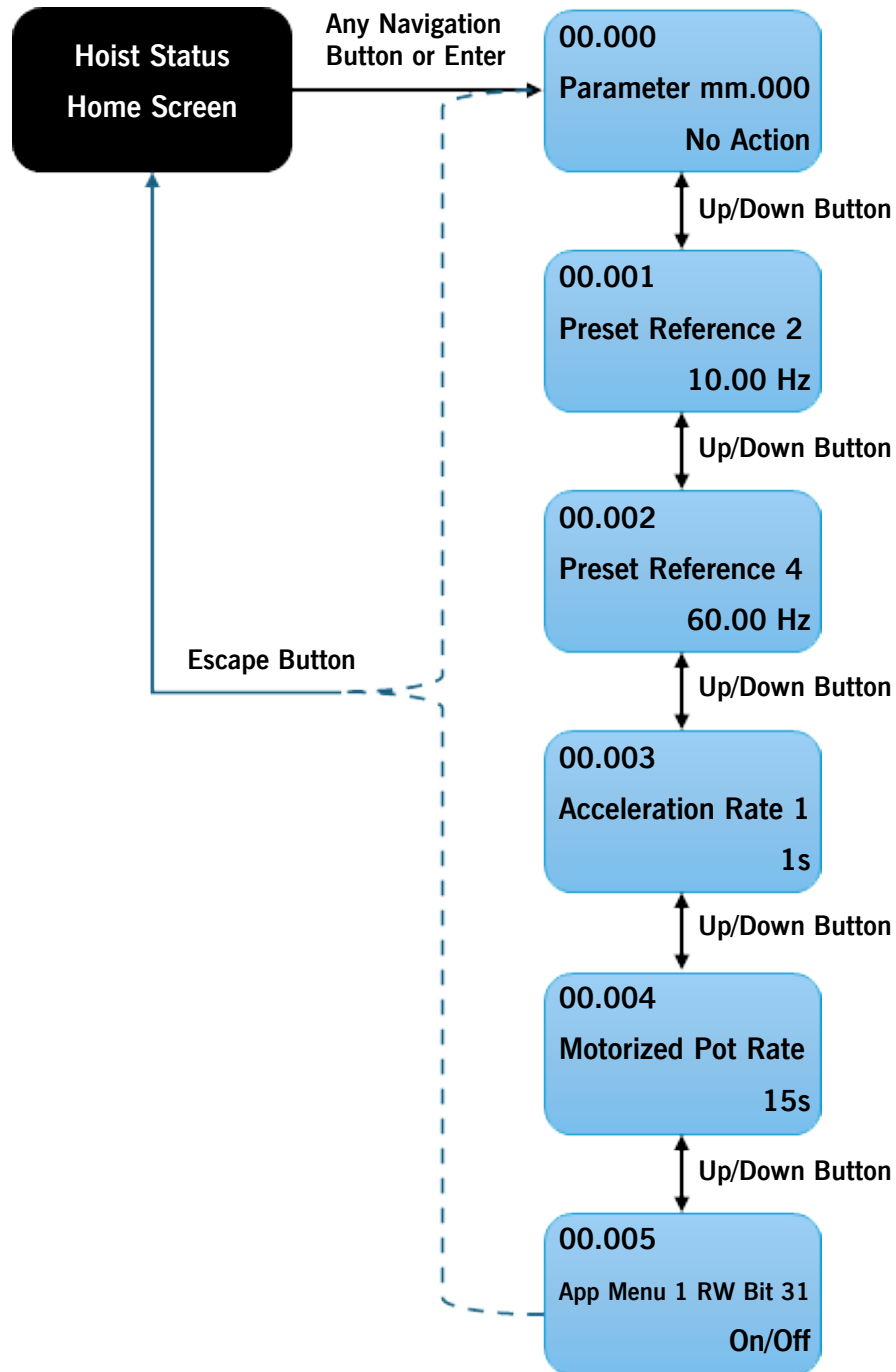

Diagram 5-4: Menu Parameter Navigation.

Parameter Menu Navigation, Continued

Diagram 5-4 shows the first 6 parameters in the drive. Each parameter has its numerical value along with the parameter's caption in the top left corner of the LCD display.

The current value of the parameter will be displayed in the bottom right corner. Some of these parameters are read only and will display the state of the parameter. Other parameters are adjustable and values can be changed/set. See **Table 5-1: Menu 00 Parameters** for the full list Menu 00 parameters and their descriptions. To return to the 'status mode' select the Escape button at any time.

Hoist Parameter Editing

Pressing the Enter button on any of the adjustable parameters in the parameter menu, will allow the user to edit the modifiable parameters.

Diagram 5-5 demonstrates editing parameter 00.001. Using the Right/Left navigation buttons will change which decimal place is being edited.

When in parameter editing, one of the digits will be underlined and flashing which represents the current digit in the parameter's value that will be changed with pressing the Up/Down Navigation buttons.

If the user is satisfied with the new value, they can press the Enter button to save the new value in the parameter. If the user wants to return to the Parameter Menu without saving changes, they can press the Escape button.

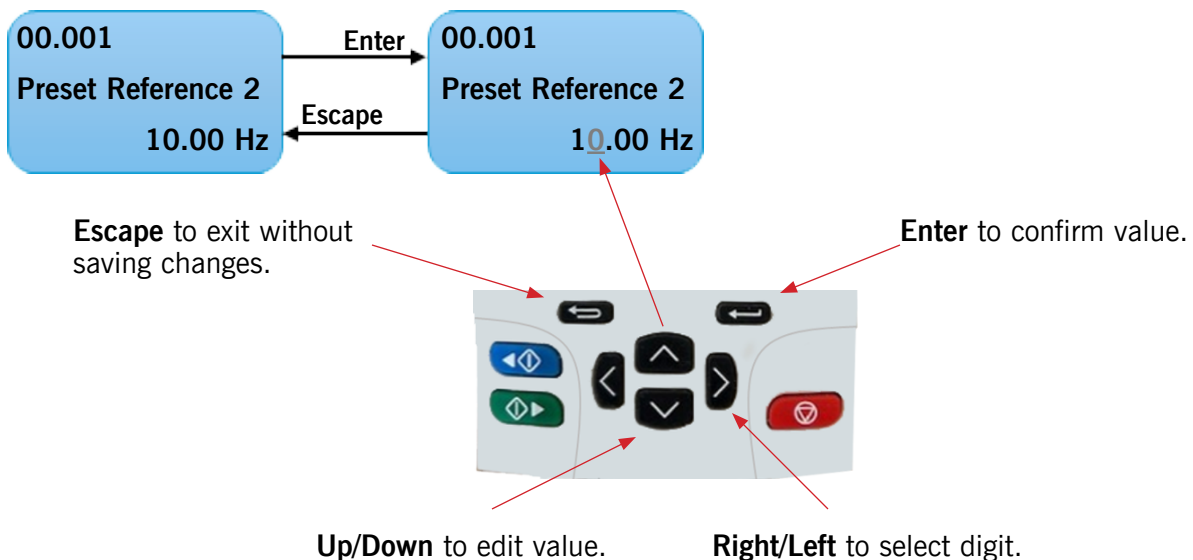

Diagram 5-5: Menu Parameter Editing.

Continued on the next page...

Performing a User Save:

1. Refer to **Table 5-1: Menu 00 Parameters**. On the keypad, navigate to Pr. 00.066 App Menu 1 RW integer 11 and enter the Save Code 1000.
2. Navigate to Pr. 00.065 App Menu 3 RW Long integer 21 and enter the password 95515.
3. Press the Stop/Reset button. The save was successful if the Pr. 00.066 Save Code returns to 0.

Speed Control Mode

The hoist can be operated in two different modes, and it can be toggled between these two modes by turning Menu 00 parameter 00.005 on or off. This will enable the change the setting to and from:

- Dual Speed Control
- 2-Step Infinitely Variable Control

When Pr. 00.005 is in the default 'Off' state, the unit will operate in the Dual Speed Control mode.

When Pr. 00.005 is in the 'On' state, the unit will operate in the 2-Step Infinitely Variable Control mode.

Dual Speed Control (mirrors the control of a normal 2-speed contactor hoist)

Operation

Pressing either of the pendant's up or down push buttons to the first detent causes the hoist to accelerate in speed to the 1st speed (Pr. 00.001 - Preset Reference 2) at a fixed accel rate (Pr. 00.003 - Acceleration Rate 1).

Pressing either of the pendant's up or down push buttons to the second detent causes the hoist to accelerate at the same fixed acceleration rate (Pr. 00.003) as for the first detent press to the 2nd speed (Pr. 00.002 - Preset Reference 4)

- 1st speed (Pr. 00.001) and 2nd speed 2 (Pr. 00.002) will be set in Hertz and will be the same speed in both up and down direction
- Accel Rate 1's (Pr. 00.003) units are in seconds. This value represents the amount of time it takes to ramp up to the max frequency of 60Hz from rest.
 - Example: If Accel Rate 1 (Pr. 00.003) = 6 sec, then it will take it ~ 6 seconds for it to ramp up to 60Hz from a stop but only 1 second to get to 10Hz from stop.)

Releasing either of the pendant's motion command push buttons from the second detent to the first detent causes the hoist to decelerate from 2nd speed (Pr. 00.002) to the 1st speed (Pr.00.001) at a fixed deceleration rate.

Releasing either of the pendant's motion command push buttons completely from either detent causes the hoist to decelerate from that set speed to a stop at the same fixed deceleration rate.

Continued on the next page...

2-Step Infinitely Variable Control

Operation

- Pressing either of the pendant's motion command push buttons to the first detent causes the hoist to accelerate to the 1st speed (Pr. 00.001 – Preset Reference 2) at a fixed accel rate (Pr. 00.003 - Acceleration Rate 1).
- Pressing either of the pendant's motion command push buttons to the second detent from the first detent causes the hoist to begin to ramp up in speed toward the 2nd speed set point (Pr. 00.002 - Preset Reference 4) at a fixed ramp rate (Pr. 00.004 - Motorized Pot Rate).
 - 1st speed (Pr. 00.001) and 2nd speed (Pr. 00.002) will be set in Hertz and will be the same speed in both up and down direction.
 - Accel rate 1's (Pr. 00.003) units are in seconds. This value represents the amount of time it takes to ramp up to the max frequency of 60Hz from rest. In 2-Step Inf. Control Mode, this parameter will only apply to the acceleration from rest-to-1st speed (Pr. 00.001). This accel time works the same as described in Dual Speed Control mode above.
 - Ramp rate's (Pr. 00.004) units are in seconds. This value represents the amount of time it takes the hoist to ramp up in speed from 1st speed (Pr. 00.001)-to-2nd speed (Pr. 00.002). This parameter is only active/applicable if the unit is put in 2-Step Inf. Variable Control mode (Pr. 00.005 = On).
 - o **Example:** If ramp rate (Pr. 00.004) is set to 10 seconds then it will take 10 seconds for the hoist to ramp up from 1st speed (Pr. 00.001) to 2nd speed (Pr. 00.002).
- Releasing either of the pendant's up or down push buttons from the second detent to the first detent before the hoist has reached 2nd speed (Pr. 00.002), the hoist will hold at that speed.
- Releasing either of the pendant's up or down push buttons from the second detent to the first detent after the hoist has reached the 2nd set speed (Pr. 00.002), the hoist will continue to hold at that speed.
- Releasing either of the pendant's up or down push buttons completely from any detent causes the hoist to decelerate from the speed the hoist was running at to a stop at the same fixed deceleration rate as the other control mode.
- There is no way to ramp down in speed in this mode. If the hold speed is higher than what was desired, the user must fully release the push button and restart the ramp up to get the desired hold speed.

Menu 00 Parameter Table

Parameter Number	Name	Type	Default	Range	Description
00.000	Parameter mm.000	Locked	0	0	Multifunctional parameter in drive that was un-needed.
00.001	Preset Reference 2	Adjustable	10.00 Hz	10-35 Hz	Used to set Speed 1 in both control modes.
00.002	Preset Reference 4	Adjustable	60.00 Hz	35-60 Hz	Used to set Speed 2 in both control modes.
00.003	Acceleration Rate 1	Adjustable	1.0 s	1-10 s	Used to set accel rate in both control modes
00.004	Motorized Pot Rate	Adjustable	6.0 s	4-15 s	Used to set the ramp rate between the two speed set points in 2-Step Inf. Control Mode
00.005	Application Menu 1 Read Write bit 31	Adjustable	Off	On/Off	Used to turn on/off 2-Step Inf Control Mode.
00.006	Jog Forward	Adjustable	Off	On/Off	Used to Jog the unit slowly upwards from the keypad for maintenance.
00.007	Jog Reverse	Adjustable	Off	On/Off	Used to Jog the unit slowly downwards from the keypad for maintenance.
00.008	Software Version	Read Only	N/A	N/A	Displays the software version of the drive should read 3000403.
00.009	Power Software Version	Read Only	N/A	N/A	Displays the power software version of the drive should read 3000006.
00.010	Time	Read Only	N/A	N/A	This displays the run time of the unit since the drive program has been downloaded to the drive.
00.011	Energy Meter: MWh	Read Only	N/A	N/A	Displays the accumulated energy transferred through the drive in MWh.
00.012	Energy Meter: kWh	Read Only	N/A	N/A	Displays the accumulated energy transferred through the drive in kWh.
00.013	Energy Cost Per kWh	Adjustable	0.0	0.0-600.0	Defines the cost of energy per kWh.
00.014	Running Cost	Read Only	N/A	N/A	Displays the running cost of the drive.
00.015	Reset Energy Meter	Adjustable	Off	On/Off	Set to 'On' to reset the energy meters.
00.016	Trip 0	Read Only	N/A	0-255	Shows the current or last trip to have occurred.
00.017	Trip 0 Sub-trip Number	Read Only	N/A	0-65535	Shows the sub-trip number for trip 0.
00.018	Trip 0 Date	Read Only	N/A	00-00-00 to 31-12-99	Shows the date at which trip 0 occurred.
00.019	Trip 0 Time	Read Only	N/A	00:00:00 - 23:59:59	Shows the time at which trip 0 occurred in the run time format.
00.020	Trip 1	Read Only	N/A	0-255	Shows the 2nd from last trip to have occurred.

Table 5-1: Menu 00 Parameters.

Menu 00 Parameter Table, Continued

Parameter Number	Name	Type	Default	Range	Description
00.021	Trip 1 Sub-trip Number	Read Only	N/A	0-65535	Shows the sub-trip number for trip 1
00.022	Trip 1 Date	Read Only	N/A	00-00-00 to 31-12-99	Shows the date at which trip 1 occurred.
00.023	Trip 1 Time	Read Only	N/A	00:00:00 - 23:59:59	Shows the time at which trip 1 occurred in the run time format.
00.024	Trip 2	Read Only	N/A	0-255	Shows the 3rd from last trip to have occurred
00.025	Trip 2 Sub-trip Number	Read Only	N/A	0-65535	Shows the sub-trip number for trip 2
00.026	Trip 2 Date	Read Only	N/A	00-00-00 to 31-12-99	Shows the date at which trip 2 occurred.
00.027	Trip 2 Time	Read Only	N/A	00:00:00 - 23:59:59	Shows the time at which trip 2 occurred in the run time format.
00.028	Trip 3	Read Only	N/A	0-255	Shows the 4th from last trip to have occurred
00.029	Trip 3 Sub-trip Number	Read Only	N/A	0-65535	Shows the sub-trip number for trip 3
00.030	Trip 3 Date	Read Only	N/A	00-00-00 to 31-12-99	Shows the date at which trip 3 occurred.
00.031	Trip 3 Time	Read Only	N/A	00:00:00 - 23:59:59	Shows the time at which trip 3 occurred in the run time format.
00.032	Trip 4	Read Only	N/A	0-255	Shows the 5th from last trip to have occurred
00.033	Trip 4 Sub-trip Number	Read Only	N/A	0-65535	Shows the sub-trip number for trip 4
00.034	Trip 4 Date	Read Only	N/A	00-00-00 to 31-12-99	Shows the date at which trip 4 occurred.
00.035	Trip 4 Time	Read Only	N/A	00:00:00 - 23:59:59	Shows the time at which trip 4 occurred in the run time format.
00.036	Trip 5	Read Only	N/A	0-255	Shows the 6th from last trip to have occurred
00.037	Trip 5 Sub-trip Number	Read Only	N/A	0-65535	Shows the sub-trip number for trip 5
00.038	Trip 5 Date	Read Only	N/A	00-00-00 to 31-12-99	Shows the date at which trip 5 occurred.
00.039	Trip 5 Time	Read Only	N/A	00:00:00 - 23:59:59	Shows the time at which trip 5 occurred in the run time format.
00.040	Trip 6	Read Only	N/A	0-255	Shows the 7th from last trip to have occurred
00.041	Trip 6 Sub-trip Number	Read Only	N/A	0-65535	Shows the sub-trip number for trip 6
00.042	Trip 6 Date	Read Only	N/A	00-00-00 to 31-12-99	Shows the date at which trip 6 occurred.

Table 5-1, Continued: Menu 00 Parameters.

Menu 00 Parameter Table, Continued

Parameter Number	Name	Type	Default	Range	Description
00.043	Trip 6 Time	Read Only	N/A	00:00:00 - 23:59:59	Shows the time at which trip 6 occurred in the run time format.
00.044	Trip 7	Read Only	N/A	0-255	Shows the 8th from last trip to have occurred
00.045	Trip 7 Sub-trip Number	Read Only	N/A	0-65535	Shows the sub-trip number for trip 7
00.046	Trip 7 Date	Read Only	N/A	00-00-00 to 31-12-99	Shows the date at which trip 7 occurred.
00.047	Trip 7 Time	Read Only	N/A	00:00:00 - 23:59:59	Shows the time at which trip 7 occurred in the run time format.
00.048	Trip 8	Read Only	N/A	0-255	Shows the 9th from last trip to have occurred
00.049	Trip 8 Sub-trip Number	Read Only	N/A	0-65535	Shows the sub-trip number for trip 8
00.050	Trip 8 Date	Read Only	N/A	00-00-00 to 31-12-99	Shows the date at which trip 8 occurred.
00.051	Trip 8 Time	Read Only	N/A	00:00:00 - 23:59:59	Shows the time at which trip 8 occurred in the run time format.
00.052	Trip 9	Read Only	N/A	0-255	Shows the 10th from last trip to have occurred
00.053	Trip 9 Sub-trip Number	Read Only	N/A	0-65535	Shows the sub-trip number for trip 9
00.054	Trip 9 Date	Read Only	N/A	00-00-00 to 31-12-99	Shows the date at which trip 9 occurred.
00.055	Trip 9 Time	Read Only	N/A	00:00:00 - 23:59:59	Shows the time at which trip 9 occurred in the run time format.
00.056	Date	Read Only	N/A	N/A	Sets Date of the unit in the month#-Day#-Year# format. Must be set for accurate trip dates.
00.057	Torque Producing Current	Read Only	N/A	0.00-9.99A	Instantaneous level of torque producing current in rms form. (Torque producing current – component of motor current responsible for generating mechanical torque in motor)
00.058	Magnetizing Current	Read Only	N/A	0.00-9.99	Instantaneous level of magnetizing current in rms form (Magnetizing current – current required to establish magnetic field in motor coils)
00.059	Motor Protection Accumulator	Read Only	N/A	0-100%	Level of the motor protection accumulator
00.060	Braking Resistor Thermal Accumulator	Read Only	N/A	0-100%	Level of the braking resistor thermal accumulator.

Table 5-1, Continued: Menu 00 Parameters.

Menu 00 Parameter Table, Continued

Parameter Number	Name	Type	Default	Range	Description
00.061	Percentage of drive thermal trip level	Read Only	N/A	0-100%	Shows the level of drive thermal trip.
00.062	Remote keypad battery low	Read Only	N/A	On or Off	On triggers when the keypads internal Battery is not fitted or the voltage is below the minimum threshold.
00.063	Status Mode Parameter 1	Adjustable	05.001	05.001-05.005	Defines the parameter displayed row 2 of the keypad when in 'status mode'.
00.064	Onboard user program: Status	Read Only	N/A	0,1,3	Status of user program. 0 means stopped, 1 means present and running, 3 means no program. Should always be 1.
00.065	App. Menu 3 RW Long integer 21	Adjustable	0	-2147483648 to 2147483648	General Read-Write long integer.
00.066	App. Menu 1 RW integer 11	Adjustable	0	-32768 to 32767	General Read-Write integer.
00.081	Reference selected	Read Only	N/A	0-60 Hz	Displays the current reference after clamps have been applied.
00.082	Pre-reference ramp	Read Only	N/A	0-60 Hz	Displays offset applied to reference.
00.083	Final demand reference	Read Only	N/A	Hz	Displays the fundamental drive demand frequency.
00.084	D.C. Bus voltage	Read Only	N/A	V	Displays the instantaneous voltage across the D.C. bus.
00.085	Output Frequency	Read Only	N/A	Hz	Shows the instantaneous drive output frequency, <u>not to be confused with reference frequency.</u>
00.086	Output Voltage	Read Only	N/A	V	Shows the instantaneous drive output voltage scaled so that it represents the rms voltage in steady state conditions.
00.087	Motor RPM	Read Only	N/A	RPM	Shows the motor RPM based off final demand reference.
00.088	Current magnitude	Read Only	N/A	A	Displays the instantaneous drive output current scaled so that it represents the rms phase current in Amps under steady state conditions.
00.089	Torque Producing Current	Read Only	N/A	A	Shows the instantaneous level of torque producing scaled so that it represents the rms phase current in Amps under steady state conditions.

Table 5-1, Continued: Menu 00 Parameters.

Menu 00 Parameter Table, Continued

Parameter Number	Name	Type	Default	Range	Description														
00.090	Digital I/O Read Word	Read Only	N/A	0000000000 to 1111111111	<p>Displays the states for the digital I/O. Each bit matches the value of the state parameter for the respective digital input so the bit value for digital inputs will be the state of the actual input before any inversion selections are applied.</p> <table border="1"> <thead> <tr> <th>Bits</th> <th>Input Name</th> </tr> </thead> <tbody> <tr> <td>0</td> <td>Brake Release</td> </tr> <tr> <td>1</td> <td>NC THRML Switches</td> </tr> <tr> <td>2</td> <td>NC Lower Limit</td> </tr> <tr> <td>3</td> <td>NC Upper Limit</td> </tr> <tr> <td>4-8</td> <td>Reserved</td> </tr> <tr> <td>9</td> <td>Brake Release</td> </tr> </tbody> </table>	Bits	Input Name	0	Brake Release	1	NC THRML Switches	2	NC Lower Limit	3	NC Upper Limit	4-8	Reserved	9	Brake Release
Bits	Input Name																		
0	Brake Release																		
1	NC THRML Switches																		
2	NC Lower Limit																		
3	NC Upper Limit																		
4-8	Reserved																		
9	Brake Release																		
00.091	Reference On	Read Only	N/A	0 or 1	Shows that the reference from the reference system is active														
00.092	Reference Select	Read Only	N/A	0 or 1	Indicates when the jog function is active														
00.094	Analog/Digital Input 1	Read Only	N/A	0% or 100%	Displays the state of run forward Digital input status in the form of a percentage where 0% is off and 100% is on.														
00.095	Analog/Digital Input 2	Read Only	N/A	0% or 100%	Displays the state of the 2nd speed digital input in the form of a percentage where 0% is off and 100% is on.														

Table 5-1, Continued: Menu 00 Parameters.

Menu 00 Parameter Table, 2-Ton Hoist Differences

Parameter Number	Name	Type	Default	Range	Description
00.001	Preset Reference 2	Adjustable	15.00 Hz	15-35 Hz	Used to set Speed 1 in both control modes
00.002	Preset Reference 4	Adjustable	60.00 Hz	35-60 Hz	Used to set Speed 2 in both control modes

Table 5-2: Menu 00 Parameters for 2-Ton Hoists.

Section 6 - Maintenance

WARNING!



Maintenance is to be performed by **properly trained and authorized personnel only.**



ELECTRICAL SHOCK HAZARD!



Maintenance work must only be carried out on an unloaded electric chain hoist with all power to the hoist disconnected and tagged out.



Refer to **Table 6-1**. Perform maintenance checks in accordance with the interval shown.

Maintenance Schedule at Normal Operation Duty Cycle	Interval		
	Daily	Every 3 months	Yearly
Visual check of the entire hoist	•		
Function check of the brake	•		
Function check of the lift limiter		•	
Check the brake gap			•
Maintenance or adjustment of the clutch			•
Wear of the load chain and chain guide		•	
Lubrication of the load chain		•	
Wear of the rubber elements (visual check) and load limiters	•		
Lubrication of single and double fall hooks, thrust bearings, check condition of the pin which prevents the hook nut from loosening and chisel punch marks			•
Check condition of safety latch	•		
Check all screws, hold down, chain guide, chain fall safety devices			•
Check condition and safe positioning of the chain container		•	
Check electric cable, power cable and pendant control			•
Check trolleys and wheels			•

Table 6-1. Maintenance Schedule.

WARNING!



If the hoist is working under harsh operating conditions such as multi-shift operation, high percentage of work with normal load, high switching, high temperature environment, or poor environmental conditions, inspection intervals should be twice as frequent, at minimum.



WARNING!

The electric chain hoist must be overhauled after it has reached its Safe Working Period (S.W.P) or at no later than 10 years if no maintenance records are available. Correct recording of the full load operating hours is the sole responsibility of the owner.



Load and Suspension Hooks

Refer to **Diagram 6-1** and **6-2** for Single Fall and Double Fall Load Hook configurations.

- Check condition of the hook (wear marks and center punch spacing).
- Check plastic cover of bottom hooks for chain 4x12 mm and 5.2x15 mm. Change if worn.
- Check function of safety latch.
- Check hook nut and securing pin.
- Check axial bearing and re-grease if necessary.
- Replace rubber buffer if worn.

Load hooks have to be replaced if the length between the chisel punch marks (Y dimension) widened more than 10%. The permissible values are shown on the hook certificate.

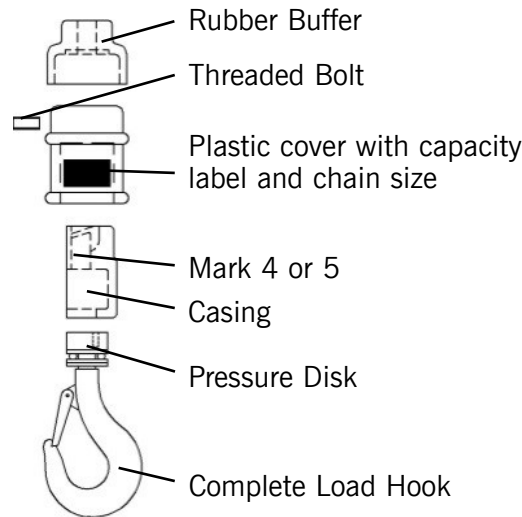

Diagram 6-1: Single Fall Load Hook.

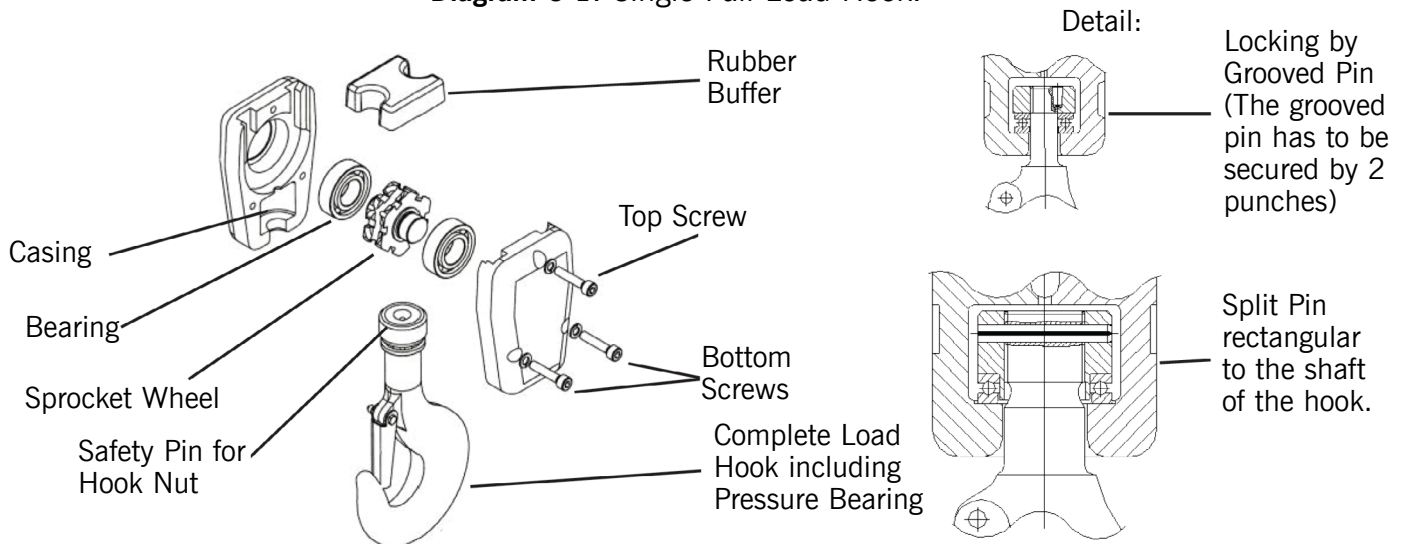

Diagram 6-2: Double Fall Load Hook.

Load and Suspension Hooks, Continued

For the assembly of the Load Hook, tighten the connection screws to the following torque values:

Chain Dimension (mm x mm)	Max. Load Capacity in Tons	Dimension of screws (metric)	Quantity of Screws		Torque in ft./lbs. (Nm)	
			Top Screw	Bottom Screws	Top Screw	Bottom Screws
7.2x21	1.25	M10x40 DIN 912	2	1	7.5 (10)	4.5 (6)

Table 6-2A. Torque Values for Single Fall Load Hook.

Chain Dimension (mm x mm)	Max. Load Capacity in Tons	Dimension of screws (metric)	Quantity of Screws		Torque in ft./lbs. (Nm)	
			Top Screw	Bottom Screws	Top Screw	Bottom Screws
7.2x21	2.0/2.5	M8x50 DIN 912	3	3	15 (20)	15 (20)

Table 6-2B. Torque Values for Two Fall Load Hook.

Single Hole Suspension Eye Hook Suspension

CAUTION!



When changing from single fall to double fall, turn the suspension eye 180 degrees. The hole position must be directly above the load hook. The relevant label on the suspension hook must be on the chain container side.



Load Chain, Chain Guide and Hold Down

WARNING!



The chain guide and hold down must be replaced if a new chain will be assembled. For chain, chain guide and hold down, use original spare parts only from manufacturer or from manufacturer’s approved suppliers.



Use of other non-authorized spare parts may cause serious accidents.

Refer to **Diagram 6-3** and **Table 6-3**. The chain must be replaced if the:

- Nominal thickness at the points of contact is reduced by 10%.
- Chain or a link is elongated by 5%, or an eleven links piece of chain is elongated by 2%.
- Links do not move properly at their contact points due to wear in the contact area.

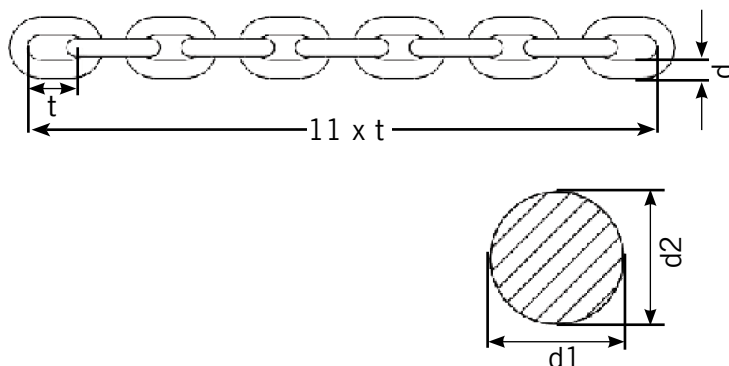

t = nominal length of one chain link
 d = nominal diameter of chain link
 d1, d2 = actual diameters

$$d_m = \frac{d1 + d2}{2}$$

Diagram 6-3. Load Chain Dimensions.

Load Chain, Chain Guide and Hold Down, Continued

Chain dimensions	mm x mm	7.2 x 21	
		inch	mm
Nominal diameter of link	d	0.28	7.2
Wear limit of diameter	dm	0.26	6.5
Length over 1 link	t	0.83	21
Wear limit of 1 link	tmax	0.87	22.1
Length over 11 links	11 x t	9.09	231
Wear limit of 11 links	(11 x t)max	9.28	235.6

Table 6-3. Load Chain Wear Tolerances.

WARNING!



Continuous monitoring of the load chain is mandatory. The load chain must be tested before starting operation and after approximately 100 operating hours or 5,000 load cycles under normal conditions and more often under harsh and severe conditions.



Load Chain Testing Procedure

- Test/check the full length of chain.
- Test/check especially uppermost and lowest chain position.
- Check for wear, cracks, deformation and other damages.

Replacing the Load Chain and the Hold Down

Refer to **Diagram 6-4**. The chain guide and the hold down **must be changed** when the load chain is being replaced.

1. Let worn chain move out.
2. Loosen screws (1).
3. Take out chain guide (2).

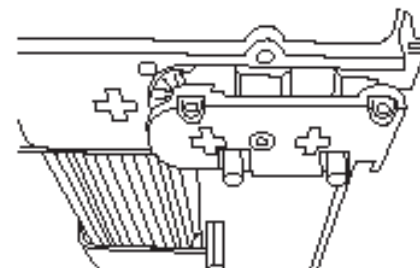
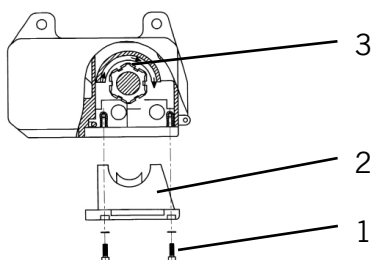

Diagram 6-4. Chain Guide Removal.

Continued on the next page...

Replacing the Load Chain and the Hold Down, Continued

Refer to **Diagram 6-5**. Perform the following steps:

4. Turn the hold down out. (3)
5. Put a new hold down in by turning it through the groove over the sprocket wheel.
6. Push chain guide in and tighten the screws.
7. Fit new chain as described in the preceding section.

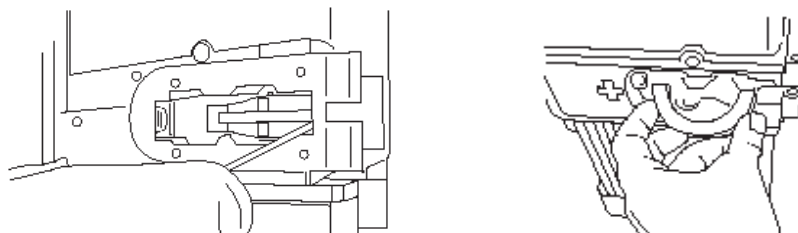

Diagram 6-5. Chain Hold Down Removal.

CAUTION!



The screws for chain guides have to be screwed in by using threadlocking paste during assembly/reassembly. All components must be free of oil or grease to achieve optimal strength. The recommended threadlocking pastes are Loctite® 243 or equivalent.



Load Chain Assembly - Single Fall Hoist

Before inserting the load chain, and to prevent damage to the Chain Guide, we recommend you reduce the clutch torque, so that the chain is not pulled with full force. After the new chain is assembled, set the clutch to the original value. Observe dimensions noted on the brake coil.

Refer to **Diagram 6-6** and **Diagram 6-7 (next page)**. Perform the following steps:

NOTE: If the hoist is delivered with a pre-assembled length of chain, the load chain can be inserted by means of a slotted chain link instead of the pull-in wire.

1. Push the pull-in wire (special tool) into and through the chain guide cross plate shown until the wire hook is pushed out the opposite side.
2. When feeding the chain into the hoist, ensure that the first link is aligned. Pull the wire so that the first link slides into the chain guide. Then operate the hoist in inching mode, lifting direction until the flat link slides in the picket of the sprocket wheel.
3. Jog the hoist in the down direction to feed the chain through.

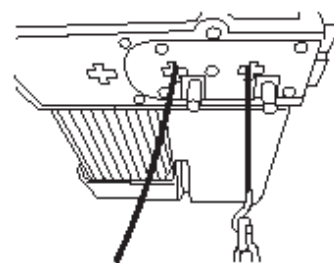
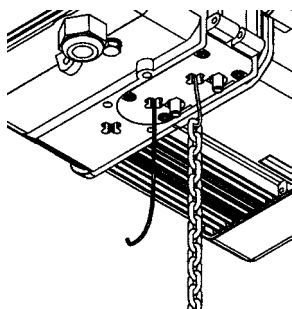

Diagram 6-6. Inserting the Push Wire.

Continued on the next page...

Load Chain Assembly - Single Fall Hoist, Continued

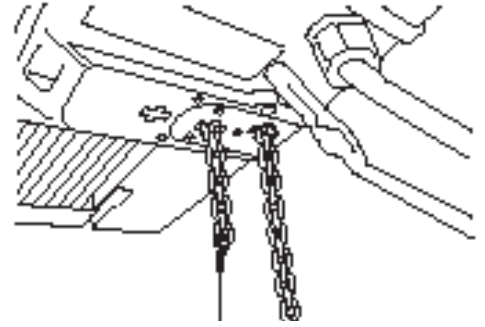
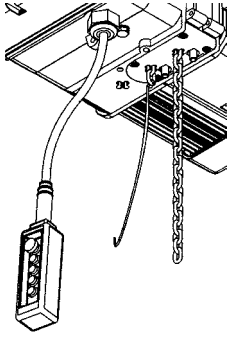
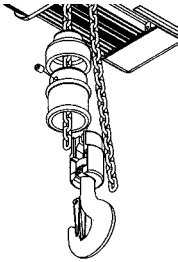

Diagram 6-7. Inserting the New Chain.

Load Hook Assembly - Single Fall Version

Refer to **Diagram 6-8**. Place the rubber buffer on the chain and assemble the load hook.



Variant without spring actuator

Diagram 6-8. Load Hook Assembly, Single Fall Version.

Load Chain and Load Hook Assembly - Double Fall Version

Refer to **Diagram 6-9**.

1. Insert the load chain into the hoist as described for the single fall version.
2. Pull the chain through the hook block using the pull in wire (special tool). When feeding the chain into the hoist, ensure that the first link is aligned parallel to the ends (hence at right angles to the sides).



Diagram 6-9. Load Chain Assembly, Double Fall Version.

CAUTION!



The chain must not be twisted between the hook block and the hoist body at any of the two chain falls! **If assembly is not possible without a twisted chain, cut one link off to allow correct assembly.**



Refer to **Diagram 6-10**.

3. Loosen the four screws of the chain guide and remove the chain guide from the hoist.



Diagram 6-10: Removing the Chain Guide Double Fall Hoist.

Refer to **Diagram 6-11**.

4. Pull the U-shaped fork out of the hoist.
5. Pull the chain end from the hook up to the cross chain hole on the under casing side of the casing.

Continued on the next page...

Load Chain and Load Hook Assembly - Double Fall Version, Continued

6. Insert the chain into the cross shaped opening. See detail below.
7. Insert the fork to capture this link.

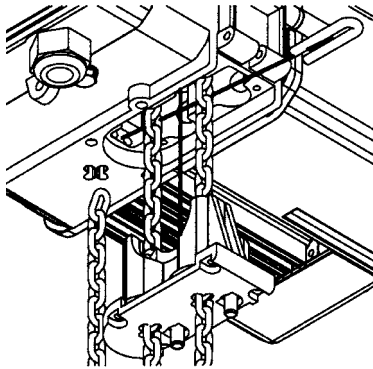

Detail:

Suspension of the second chain fall

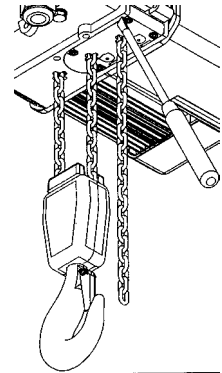
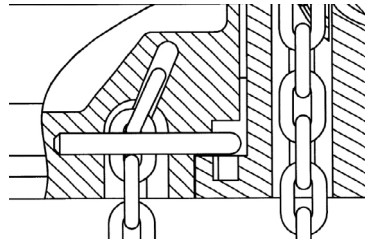

Diagram 6-11. Attaching the Second Chain Fall to the Hoist.

8. Pull hard downward on the chain to ensure that it is securely attached.
9. Re-assemble the chain guide.
10. Double check that the chain is not twisted.
11. Lubricate the entire length of chain.

WARNING!



Do not put the hook block through the two chain falls.

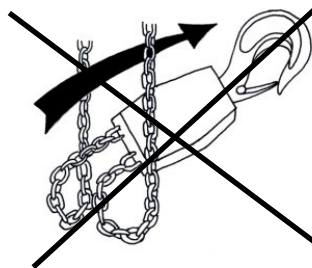

Lift Limiter Assembly

Refer to **Diagram 6-12**.

1. Lower the load hook to leave 20 inches (50 cm) of the dead end of the load chain at the dead end side.
2. Attach the rubber buffer for the lift limiter onto the remaining dead end of chain.
3. Attach the lift limiter onto the 3rd link of the dead end (standard).
4. Attach the lift limiter 20 inches (50 cm) away from the dead end when the chain is fixed to the hoist body (option).

Continued on the next page...

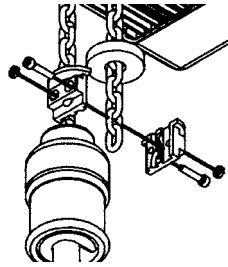
Lift Limiter Assembly, Continued

Variant without spring actuator

Diagram 6-12: Attaching the Lift Limiter.**CAUTION!**

The lift limiter is designed to prevent the dead end of chain running out of the hoist. It is used as an emergency stop and cannot be used regularly as an operational lower limit switch. If the rubber buffer of the lift limiter has a metal washer, this washer should be mounted toward the electric chain hoist body.

**Chain Bag Assembly and Filling**

1. Assemble chain container.
2. Allow the chain to run into the chain container.
3. Lubricate the entire length of the chain.

WARNING!

Fill the chain bag only by running the chain through the hoist by using the motor (press 'UP' button). To prevent knots inside the chain bag, do not feed a long piece of chain into the chain container directly.

**Checking the Hoist Brake****WARNING!**

Do not attempt to dismantle the brake or adjust the brake air gap.



NOTE: The brake is maintenance free. To guarantee its correct function, the air gap must be checked. When the maximum air gap is reached, replace the brake. The specifications for the air gap and coil resistance are shown on a sticker on the brake (**Diagram 6-13**).

**Diagram 6-13.** Brake Type Plate.

Checking the Hoist Brake, Continued

- Check visually for free movement of the anchor plate.
- Brake coil, anchor plate screws and bushings shall be free of rust/corrosion.
- Check for excessive amount of brake dust and remove dust if necessary.

Checking the Hoist Brake Air Gap

ELECTRICAL SHOCK HAZARD!



Maintenance work must only be carried out on an unloaded electric chain hoist with all power to the hoist disconnected and tagged out.



1. Loosen screws of cap for gear cover.
2. Remove cap for gear cover.
3. Refer to **Diagram 6-14**. Measure air gap between magnet coil and anchor plate with feeler gauge.
4. Compare measured air gap value with maximum air gap value on the **Table 6-4**.
5. If necessary, replace brake.

Brake Type	Screws	Torque ft-lbs (Nm)	Coil Resistance	Nominal Air Gap (mm)	Maximum Air Gap (mm)
BFK 457-08	3xM5	4.1 (5.5)	1681	0.008 (.2)	0.020 (.5)

Table 6-4: Brake Specifications.

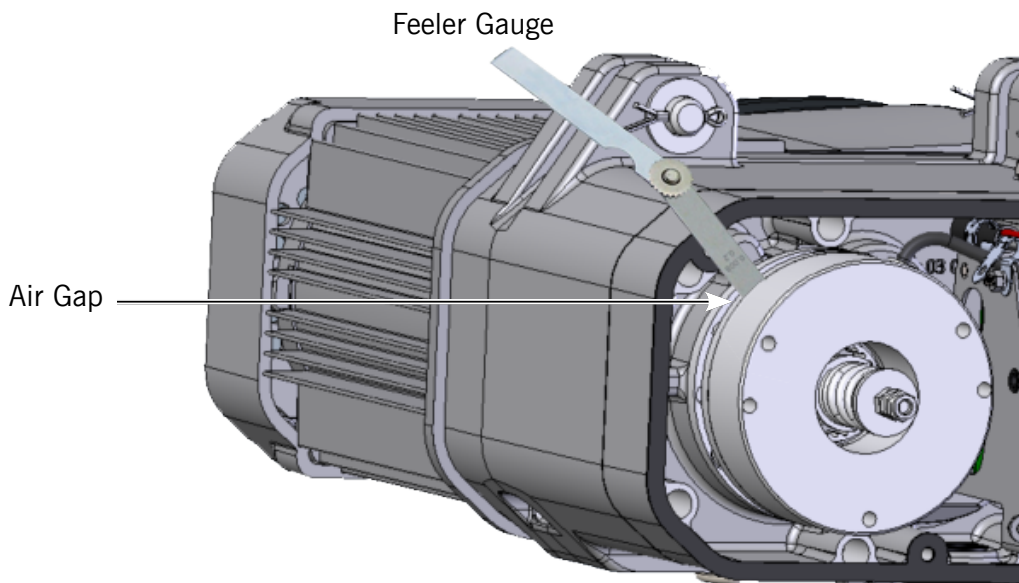

Diagram 6-14: Checking the Brake Air Gap.

Continued on the next page...

Hoist Brake Replacement

WARNING!



Brake replacement **MUST** be completed without a load on the hoist.



1. Loosen screws of Brake Cap.
2. Allow the Brake cover to hang by the lanyard.
3. Disconnect brake cables.
4. Refer to **Diagram 6-15**. Loosen the three fastening screws of the brake unit.

WARNING!



Oily brakes may lead to serious accidents.
The brake friction lining must not come into contact with any lubricant oil, grease or similar materials. Replace oily or greased brakes.



5. Remove worn out brake unit.
6. Fit new brake unit onto the motor shaft.
7. Fit the brake unit using the three screws included with the replacement unit.
8. Tighten the screws with tightening torque according to **Table 6-4**.
9. Connect brake cables according to wiring diagram.
10. Reinstall Brake Cap.

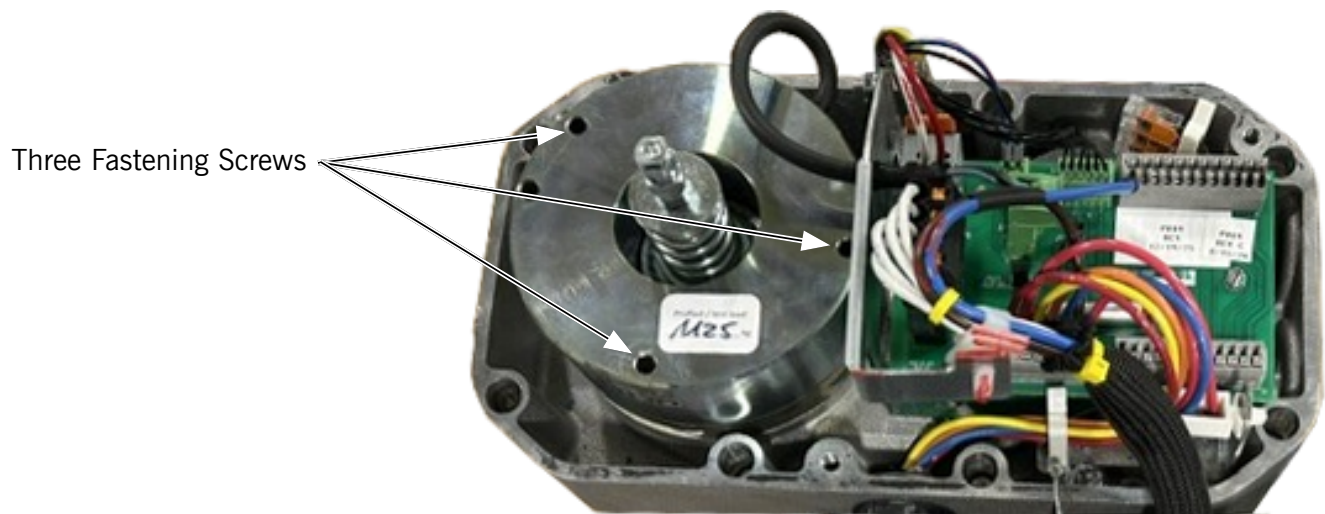

Diagram 6-15. Brake Disassembly.

Lift Motor Components

Refer to **Diagram 6-16**. The Lift Motor (5) is a modular assembly. The Cooling Fan (4) is mounted on the shaft under the Motor Fan Cap (2). The Clutch Hub (12) with a Coupling (13) is mounted with a key and retaining ring onto the drive side of the Lift Motor (5). The Motor Flange (7) has a center ring and four holes for fixing it to the hoist body.

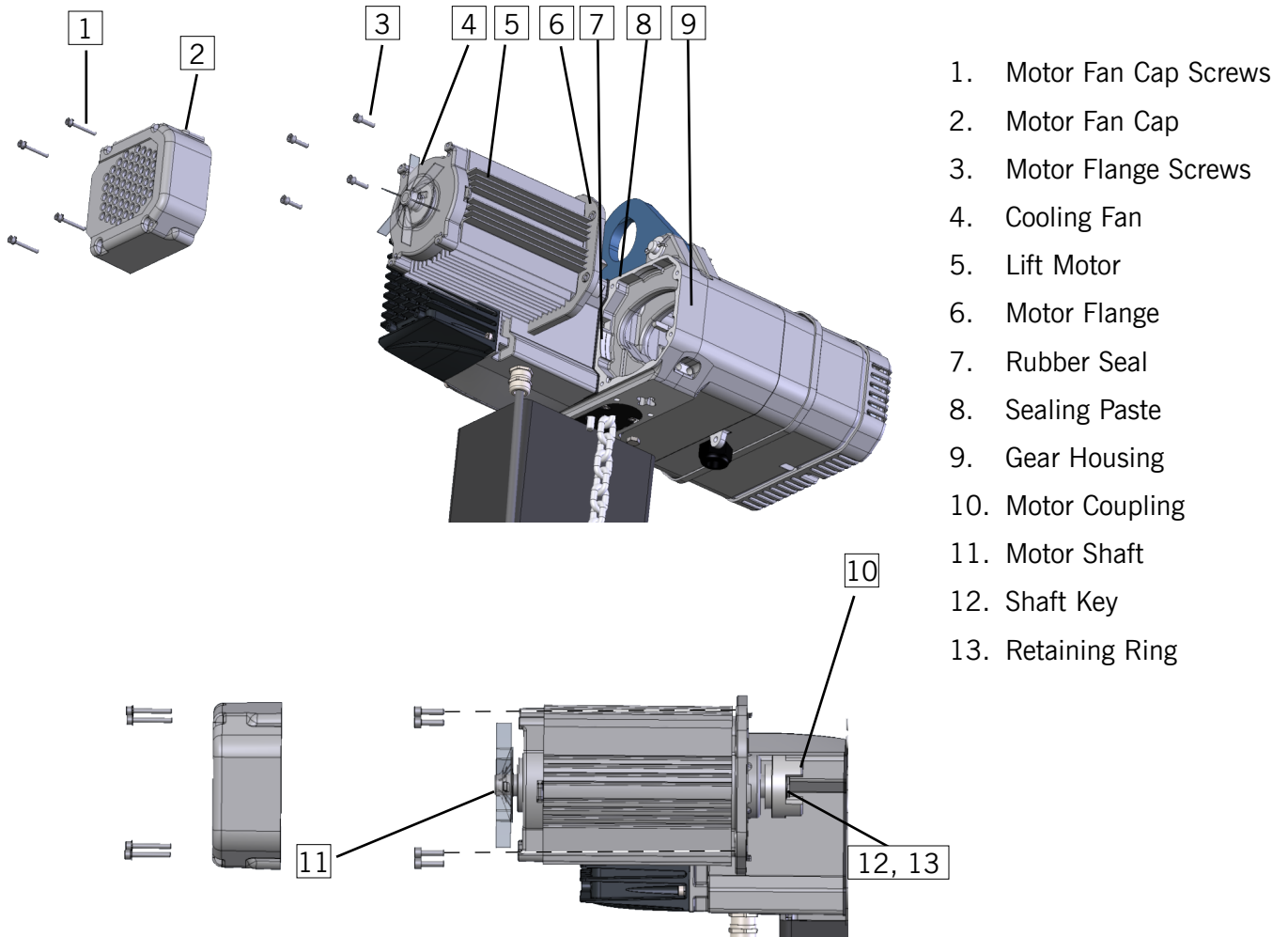

Diagram 6-16. Lift Motor Components.

Checking the Electric Limit Switches

- Visually check the actuation of the pins and proper function of the spring return.
- Check function of limit switches. If the function is not correct, check the wiring of the limit switches according to wiring diagram.

Safety Clutch

CAUTION!



The sliding clutch is located between the lifting motor and main pinion shaft and transmits the torque. The clutch limits the transmission of torque depending on the setting and prevents overloading of the hoist unit and/or suspension points.



The patented safety clutch acts as an emergency stop if the hook or end stop runs accidentally against the hoist body in top/bottom position. The clutch is designed to act as an emergency limit and should not be intentionally used as a stop during regular operation of the hoist.

The Safety Clutch is situated just after the motor shaft, before the brake. Even in the case of heavy wear of the clutch lining, the brake will prevent uncontrolled lowering of the load.

WARNING!



To stop the load in case of worn out clutch lining, take fingers off the 'UP'/'DOWN' buttons and the load will be stopped immediately.



Refer to **Diagram 6-18** and **Diagram 6-19**. The Clutch is easily adjustable and accessible. The wear resistant lining material does not require readjustment if the instructions of this manual are followed and the hoist is not overloaded.

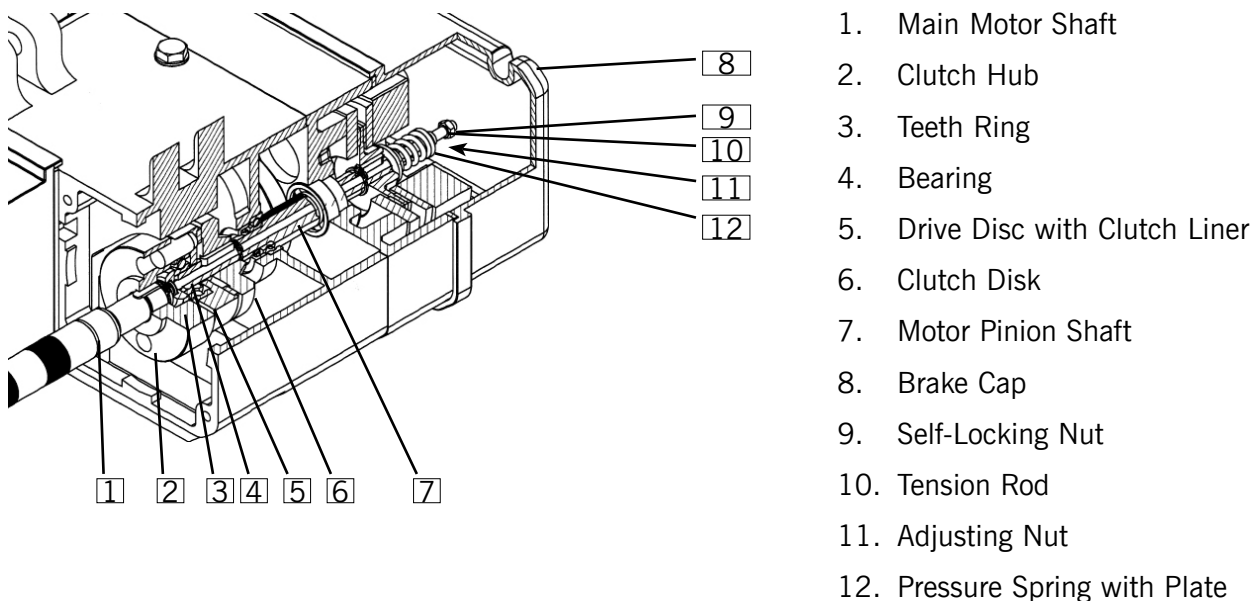

Diagram 6-18. Sliding Clutch Components.

Safety Clutch Adjustment

CAUTION!



Sliding clutch adjustment should only be completed by trained and qualified personnel.



Refer to **Diagram 6-19** and perform the steps below.

1. Apply a test load equal to 1.25 times the nominal/rated load onto the load hook.
2. Check that the test load can be lifted, and then lower the test load to the floor.
3. Decrease or increase clutch torque until the test load is just lifted by adjusting the clutch as follows:
 - A. Loosen and remove the Braking Resistor Cap and Brake Side Cap.
 - B. Use a wrench to hold the retaining self-locking nut.
 - C. Use a second wrench to loosen/tighten the Self-Locking Nut to compress/decompress the Pressure Spring with Plate until the required test load is just lifted.
 - D. Press the pendant buttons to check operation of the Lift Motor.
 - E. Recheck the clutch torque by lifting the test load.
6. Record clutch setting in the inspection and test logbook.
7. Tag the clutch setting.

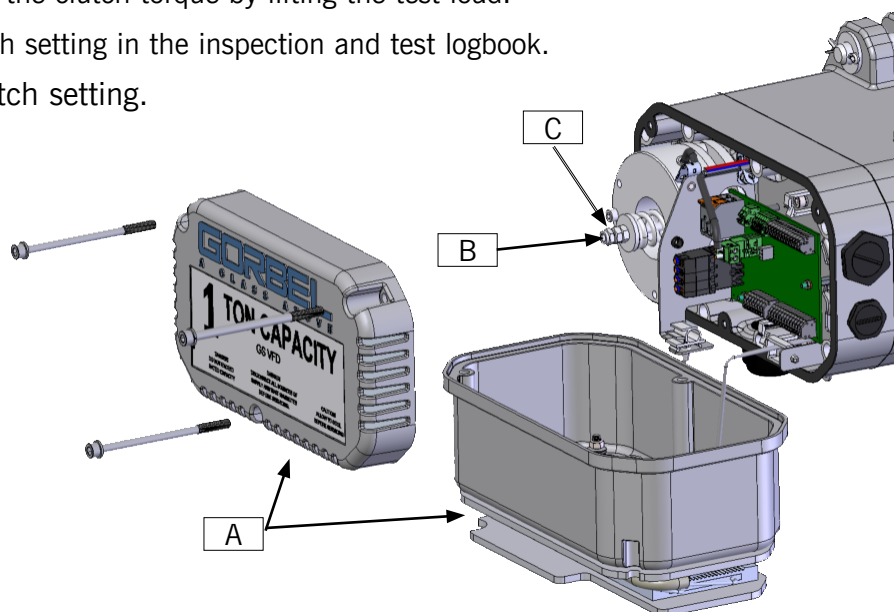

Diagram 6-19. Sliding Clutch Adjustment.

CAUTION!



The Safety Clutch is set with a test load by the manufacturer. After changing or replacing the lift motor, it is not necessary to reset the clutch. However, a test with nominal load is required.

The original distance between the end of the tension rod and the coupling pressure plate is marked on a tag on the brake coil.



Continued on the next page...

Safety Clutch Adjustment, Continued

Checking the Release Limit of the Sliding Clutch During Regular Inspections

The sliding clutch release limit must to be checked by a trained specialist once a year. Check if the hoist lifts the nominal load. The hoist must not lift more than 1.6 x the nominal load. If test loads larger than the nominal load are not available, the release limit can be checked by a clutch testing device. Use such equipment strictly according to its manual.

CAUTION!



Testing the clutch release limit with a Clutch Testing Device must not take the place of performing a load test with a nominal load.



Lubrication

Load Chain Lubrication

CAUTION!



The links along the entire length of the load chain must be lubricated with penetrating gear oil before starting operation for the first time and during operation.



Refer to **Diagram 6-20**.

- To get lubricant into the links, lubricate the chain with no load. Lubricate the shaded areas of the link.
- Lubricate the chain in the chain box.
- Clean chain before repeated lubrication.
- Amount of lubricant and frequency of lubrication may vary due to operating conditions.
- Lubricate chain every 3 months at a minimum.
- Shorten lubrication intervals if necessary.
- Use a dry-film lubricant, e.g. lubricating varnish. Graphite powder, should be used when ambient influences are conducive to wear (sand, emery).

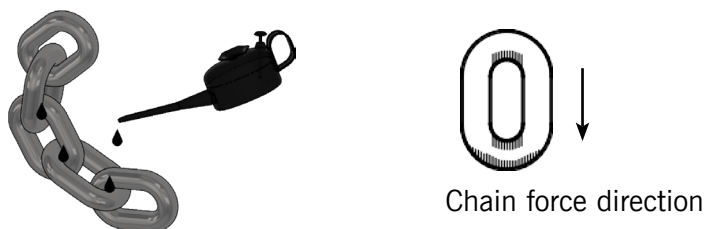

Diagram 6-20. Chain Lubrication.

Load Chain Lubrication, Continued

The following lubricants are recommended for lubrication of chain depending on operating conditions:

Supplier	Lubricant designation
Mobil	Mobilux 150
Mobil	Mobilux EP #0
or equivalent lubricant	

Table 6-4. Recommended Chain Lubricants.

Gear Lubrication

The gear is already filled with oil by the manufacturer. It is a lifetime lubrication, but the oil must be changed if the gear box has to be opened.

If a visible leak occurs from the gear vent, repair it and change the oil to be sure that the correct amount of oil is in the gear box.

CAUTION!



Ensure that waste oil is disposed of in compliance with applicable regulations.



Gear Oil Amounts

Hoist Type from Type Plate	Amount in gal (ml)
070	0.092 (350)

Table 6-5. Oil Amount for GS VFD Chain Hoist.

In Specification Gear Oil

Supplier	Oil designation
Fuchs	Renolin CLP 220
Castrol	Alpha Zn 200
ESSO	EP 220
Mobil	Mobil gear 630 or SHC 630
Shell	Omala 220
ELF	Reducteif SP 220
BP	XP 220 BP Energol GR

Table 6-6. GS VFD Chain Hoist In-Spec Gear Oil.

Load Hook Bearing and Chain Sprocket Lubrication

CAUTION!



Lubricate the anti-friction bearings on the hook and the chain sprocket after approximately 20,000 lifting cycles or once a year. If in heavy use, shorten the interval and use a special anti-friction bearing grease.



Supplier	Lubricant designation
Mobil	Mobilux 150
Mobil	Mobilux EP #0
Or equivalent lubricant	

Table 6-7. GS VFD Chain Hoist In-Spec Bearing Lubricant.

Trolley Lubrication

CAUTION!



Trolley Roller Bearings must be lubricated once per year, or sooner if in heavy use.



Supplier	Lubricant designation
Mobil	Mobilux 150
Mobil	Mobilux EP #0
Or equivalent lubricant	

Table 6-8. GS VFD Chain Hoist In-Spec Trolley Lubricant.

This page intentionally left blank.

Section 7 - Troubleshooting

Troubleshooting Overview for the GS VFD Hoist

Event Classifications

The GS VFD Hoist will declare faulted conditions through **Trips, Alarms** and **Keyboard Status**

There are differing reasons for each of these types of indications, as described below.

Trips

Trips are the MOST severe type of fault event. This event type latches and will prevent motor operation until the reason for the trip is resolved and the VFD is able to reset the trip in the below two manners:

- **Automatic Reset:** When a trip occurs, the unit will attempt to automatically reset the trip 5 separate times within a 2.5-minute window. If the cause of the trip ceases, the trip will be reset, and normal operation will be allowed.
- **Manual Trip Reset:** If the cause of the trip does not cease, the trip will remain active and will require an operator to correct the active issue(s) before performing one of or all manual trip reset operations:
 - Cycling the E-Stop switch.
 - Pressing the red 'Reset' button on the keypad
 - Cycling the mains power

During a trip condition, the upper row of the display indicates that a trip has occurred (Row 1 indicates "Trip"), and the lower row of the keypad display will show the trip string. Some trips have a sub-trip number to provide additional information about the trip.

If a trip has a sub-trip number, the sub-trip number is flashed alternately with the trip string unless there is space on the second row for both the trip string and the sub-trip number to be displayed. In this case both the trip string and sub-trip information is displayed separated by a decimal point.

The trip message disappears from the keypad and no longer shows as an active trip when the unit is reset. The past 10 trip's information (code, sub-trip code, date, & time) is accessible in locations 00.018 through 00.055 when in 'parameter mode' on the keypad.

Alarms

Less severe than a Trip, this event type may restrict motion when active depending on the specific Alarm. When declared, they cause an alarm string alternating with the drive's status string to be displayed on Row 1 of the keypad display.

If an action is not taken to eliminate any alarm except "Limit Switch," the hoist may eventually fault.

Possible Alarm actions include: Prevent motion in a direction, reduce use, and check main AC supply.

NOTE: Alarms are not displayed when a parameter is being edited.

Keypad Status

When the hoist is not in the Ready or Run state, the Keypad's upper row describes the state with the status strings in **Table 7-1**. Keypad Status Strings are not visible when in 'Hoist Parameter' or 'Hoist Parameter Edit' modes. **NOTE:** An Inhibit message will be displayed when the E-Stop is depressed.

Row 1 String	Description
Inhibit	The hoist is inhibited and cannot be run.
Supply Loss	Supply loss conditions have been detected.
Trip	The hoist is tripped and is no longer controlling the motor. The Trip Code appears in display Row 3.
Under Voltage	The hoist is in an under-voltage state.

Table 7-1. Keyboard Status Strings.

Troubleshooting Overview for the GS VFD Hoist, Continued

General Visual Inspection - All PCBs and Hoist Compartments

Other than observing the Trips, Alarms and Keypad Status, the following inspection should be completed for any of the PCBs and the compartments in which they are contained:

1. Terminal compartment should be clean and dry.
2. Check PCB contacts for corrosion. There should be no trace of powder.
3. Check that all cables are well-seated and routed correctly.
4. Ensure there are no loose or pinched wires.
5. Ensure there is no damaged insulation.

ELECTRICAL SHOCK HAZARD!



High voltages which could result in serious injury or death and property damage are present when the UI Cover is off. **Only qualified technicians are authorized to turn on hoist power when the User Interface is extended from the hoist.**



Diagnostic LEDs

There are LEDs on the Low Voltage Control PCB and the VFD PCB (230 or 460 V). **Tables 7-2** and **7-3** provide information that may be useful in troubleshooting the hoist. Refer to [Diagram 7-3. Low Voltage Control PCB \(230V or 460V\)](#) and [Diagram 7-2. VFD PCB and Connectors](#) to locate the PCBs and LEDs.

LED	Machine State	Color	Sequence	Keypad Display
STO Status LED	Emergency Stopped	Not Lit		Inhibit
	E-Stop Deactivated	Green	Steady	Normal Status strings
Therm Status LED	Motor and/or Resistor Thermal Switch is Tripped/Open	Not Lit		Trip (6)
	Motor and/or Resistor Thermal Switch is Closed	Green	Steady	Normal Status strings

Table 7-2. Low Voltage Control PCB LEDs.

LED	Machine State	Color	Sequence	Keypad Display
VFD Status LED	No AC Mains Present	Not Lit		Blank
	No Trip AC Mains Present	Green	Steady	Normal Status strings
	The Hoist VFD is active	Green	Flashing	Normal Status strings
	The Hoist is in a Trip state	Red	Steady	Trip String
	The Hoist is in an Alarm state	Red	Flashing	Alternating Alarm and Status strings

Table 7-3. VFD PCB LED.

Troubleshooting Tables

Refer to **Table 7-4**, and **7-5** which contains additional troubleshooting information for the GS VFD Hoist. For any unresolved failures, contact **Gorbel After the Sale Service at (800) 821-0086**.

Trip String	Trip Code	Sub-Trip Code	Trip occurs when...	Recommended action
Brake R Too Hot	19	-	Braking Resistor Accumulator Calculation in VFD (PR 00.060) reached 100%	Allow hoist to rest while the Braking Resistor Accumulator Calculation in VFD (PR 00.060) falls back below 95%. Reduce down-stroke duration and/or load. Reduce duty cycle.
Drive Config	232	2	The power stage hardware detected is invalid	Safely unload the hoist if loaded. Contact Gorbel After the Sale Service at (800) 821-0086
		3	The power stage hardware does not match the VFD Configuration Data	
EEPROM Fail	31	1	The most significant digit of the internal parameter database version number has changed	Safely unload the hoist if loaded. Perform a User Save before the supply to the drive is removed. Perform a Manual Trip Reset Contact Gorbel if trip persists.
		2	The CRC's applied to the parameter data stored in internal non-volatile memory indicate that a valid set of parameters cannot be loaded.	
		3	The drive mode restored from internal non-volatile memory is outside the allowed range for the product or the derivative image does not allow the previous drive mode.	
		4	The drive derivative image has changed.	
		5	The power stage hardware has changed.	
		8	The control board hardware has changed.	
		9	The checksum on the non-parameter area of the EEPROM has failed.	
External Trip	6	3	Motor and/or Resistor over temperature switch changes state to indicate an over-temperature condition.	Allow the hoist to cool off (30 min if possible) to allow switches to return to operational state. Duty cycle and/or Ambient temperature may need to be reduced Check Cable Assemblies: 95556, 95500.M460/95500.M230, 95559, & 95566.

Table 7-4. Trip String Indications.

Troubleshooting Tables, Continued

Trip String	Trip Code	Sub-Trip Code	Trip occurs when...	Recommended action
File Changed	247	-	The VFD configuration file has changed in the power stage processor and so a power cycle is required.	Safely unload the hoist if loaded. Perform a User Save before the supply to the drive is removed. Perform a Manual Trip Reset Contact Gorbel if trip persists.
FW incompatible	237	-	The user firmware is incompatible with the power firmware.	Safely unload the hoist if loaded. Contact Gorbel.
HF01	-	-	A CPU address error has occurred. This trip indicates that the control PCB on the VFD has failed.	Safely unload the hoist if loaded. Contact Gorbel.
HF02	-	-	A DMAC address error has occurred. This trip indicates that the control PCB on the VFD has failed.	Safely unload the hoist if loaded. Contact Gorbel.
HF03	-	-	A bus fault has occurred, indicating a VFD PCB failure.	Safely unload the hoist if loaded. Contact Gorbel.
HF04	-	-	A usage fault has occurred, indicating a VFD PCB failure.	Safely unload the hoist if loaded. Contact Gorbel.
HF07	-	-	A watchdog failure has occurred, indicating a VFD PCB failure.	Safely unload the hoist if loaded. Contact Gorbel.
HF08	-	-	A CPU Interrupt crash has occurred, indicating a VFD PCB failure.	Safely unload the hoist if loaded. Contact Gorbel.
HF09	-	-	A free store overflow has occurred, indicating a VFD PCB failure.	Safely unload the hoist if loaded. Contact Gorbel.
HF11	-	1 or 2	A non-volatile memory communication error has occurred, indicating a VFD PCB failure.	Safely unload the hoist if loaded. Contact Gorbel.
HF12	-	1-4	A main program stack overflow occurred, indicating a VFD control PCB failure.	Safely unload the hoist if loaded. Contact Gorbel.
HF16	-	-	An RTOS error occurred, indicating a failed VFD control PCB.	Safely unload the hoist if loaded. Contact Gorbel.
HF18	-	1-3	The internal flash memory of the VFD has failed when writing option module parameter data.	Safely unload the hoist if loaded. Contact Gorbel.
HF19	-	-	The CRC check on the VFD firmware has failed.	Safely unload the hoist if loaded. Contact Gorbel.
HF23	-	-	Hardware fault.	Safely unload the hoist if loaded. Contact Gorbel.

Table 7-4, Continued. Trip String Indications.

Troubleshooting Tables, Continued

Trip String	Trip Code	Sub-Trip Code	Trip occurs when...	Recommended action
I cal. range	231	-	A current calibration range error occurs in the VFD.	Safely unload the hoist if loaded. Contact Gorbel.
I/O Overload	26	1	The total current drawn from the digital output and/or 24V supply load on control terminals is too high.	Check that there are no unapproved ancillary loads on digital outputs and 24VDC. Check control wiring is correct and undamaged in the following Cable Assemblies: 95556, 95568, 95559, 95566, and pendant/festooned control wiring.
Motor Too Hot	20	-	Motor Protection Accumulator Calculation in the VFD (Pr.00.059) reached 100%	Ensure the load is not jammed or sticking. Allow hoist to rest while the Motor Protection Accumulator Calculation (PR.00.059) drops from 100%. Reduce upstroke duration and/or load. Reduce duty cycle.
No Power board	236	-	The control board cannot establish a communication link with the power stage within 5 seconds of powering up.	Safely unload the hoist if loaded. Contact Gorbel.
Oht dc bus	27	-	One of the VFD's DC bus component over temperature thresholds is exceeded based on a software thermal model. The VFD includes a thermal protection system to protect the DC bus components within the drive.	Allow the Hoist to rest while the Percentage of Drive Thermal Trip (PR.00.061) falls back below 95%. Reduce the load. Reduce duty cycle. Check the AC supply voltage balance and levels
Oht Inverter	21	-	An IGBT junction over-temperature has been detected based on a firmware thermal model in the VFD.	Allow the Hoist to rest while the Percentage of Drive Thermal Trip (PR 00.061) falls back below 95%. Reduce the load. Reduce duty cycle. Check the AC supply voltage balance and levels Increase Acceleration time (Pr.00.003)

Table 7-4, Continued. Trip String Indications.

Troubleshooting Tables, Continued

Trip String	Trip Code	Sub-Trip Code	Trip occurs when...	Recommended action
Oht Power	22	-	A power stage over-temperature has been detected internally to the VFD.	Allow the Hoist to rest while the Percentage of Drive Thermal Trip (PR.00.061) falls back below 95%. Reduce the load. Reduce duty cycle. Check the AC supply voltage balance and levels Increase Acceleration time (Pr.00.003)
OI ac	3	-	The instantaneous drive output current has exceeded a specified threshold. This trip cannot be reset until 10 seconds after the trip was initiated.	Increase Acceleration time Pr.00.003) Check for short circuits in the following Cable Assemblies: 95500.M460/95500.M230 & 95500.VFD Check motor insulation using an insulation tester if possible Reduce load
OI Brake	4	-	An over current has been detected in braking IGBT or braking IGBT protection has been activated. This trip cannot be reset until 10 seconds after the trip was initiated.	Check the following Cable Assemblies: 95500.R & 95559. Check braking resistor insulation.
Out Phase Loss	98	1	U phase is not connected when drive is enabled.	Check the 'U phase' wiring on the following Cable Assemblies: 95500.M460/95500.M230 & 95500.VFD
		2	V phase is not connected when drive is enabled.	Check the 'V phase' wiring on the following Cable Assemblies: 95500.M460/95500.M230 & 95500.VFD
		3	W phase is not connected when drive is enabled.	Check the 'W phase' wiring on the following Cable Assemblies: 95500.M460/95500.M230 & 95500.VFD
		4	The drive output frequency is above 4 kHz and a phase is disconnected for a specified time.	Check the wiring on the following Cable Assemblies: 95500.M460/95500.M230 & 95500.VFD
Output Phase U	228	-	The VFD is enabled and it switches the negative DC bus to the 'U phase' terminal to detect a ground fault. If current is detected on this motor winding the drive will trip OI.E1	Check the 'U phase' wiring on the following Cable Assemblies: 95500.M460/95500.M230 & 95500.VFD Check motor insulation using an insulation tester if possible.

Table 7-4, Continued. Trip String Indications.

Troubleshooting Tables, Continued

Trip String	Trip Code	Sub-Trip Code	Trip occurs when...	Recommended action
Output Phase V	229	-	The VFD is enabled and it switches the negative DC bus to the 'V phase' terminal to detect a ground fault. If current is detected on this motor winding the drive will trip OI.E2	Check the 'V phase' wiring on the following Cable Assemblies: 95500.M460/95500.M230 & 95500.VFD Check motor insulation using an insulation tester if possible.
Output Phase W	230	-	The VFD is enabled and it switches the negative DC bus to the 'W phase' terminal to detect a ground fault. If current is detected on this motor winding the drive will trip OI.E3	Check the 'W phase' wiring on the following Cable Assemblies: 95500.M460/95500.M230 & 95500.VFD Check motor insulation using an insulation tester if possible.
Over Volts	2	0-2	The VFDs DC link voltage exceeds the threshold.	Check the Brake Resistor wiring/connections on the following Cable Assemblies: 95500.R & 95559. Check for AC Mains Supply level & quality which can cause the DC bus to rise. Check motor insulation using an insulation tester if possible.
Phase Loss	32	00000 or 01010	The VFD detects an input phase loss or large supply imbalance.	Check the AC supply voltage balance and level at full load. Check for mechanical resonance with the load. Reduce load. Reduce duty cycle.
Power Board HF	235	-	Power processor had a hardware fault.	Safely unload the hoist if loaded. Contact Gorbel.
Power Boot Mode	245	-	Power board is in bootloader mode	Safely unload the hoist if loaded. Contact Gorbel.
Power Comms	93	1-4	No communication between the control board processor and the power board processor in the VFD.	Safely unload the hoist if loaded. Contact Gorbel.
Power Data	220	0-8	The data in the control board and power stage of the VFD does not match.	Safely unload the hoist if loaded. Contact Gorbel.
Power Down Save	37	-	An error has been detected in the power down save parameter saved in non-volatile memory.	Safely unload the hoist if loaded. Contact Gorbel.
PSU	5	-	One or more internal to the VFD power supply rails are outside limits or overloaded.	Safely unload the hoist if loaded. Contact Gorbel.

Table 7-4, Continued. Trip String Indications.

Troubleshooting Tables, Continued

Trip String	Trip Code	Sub-Trip Code	Trip occurs when...	Recommended action
Soft Start	226	1	The soft start relay in the VFD failed to close or the soft start monitoring circuit has failed	Safely unload the hoist if loaded. Contact Gorbel.
STO Error	234	-	STO board not fitted in the VFD.	Safely unload the hoist if loaded. Contact Gorbel.
Stored HF	221	-	A hardware trip (HF01 – HF18) has occurred and the drive has been power cycled. The sub-trip number identifies the HF trip.	Safely unload the hoist if loaded. Contact Gorbel.
Sub-Array RAM	227	-	An option module derivative or user program image has requested more parameter RAM than is allowed.	Safely unload the hoist if loaded. Contact Gorbel.
Temp Feedback	218	0 or 1010	A fault with a thermistor in the Power stage of the VFD.	Safely unload the hoist if loaded. Contact Gorbel.
User Program	249	0-200	An error has been detected in the onboard user program image.	Safely unload the hoist if loaded. Contact Gorbel.
User Save	36	-	An error has been detected in the user save parameters saved in non-volatile memory. For example, following a user save command, If the power to the drive was removed when the user parameters were being saved.	Safely unload the hoist if loaded Allow sufficient time to perform a user save before the supply to the drive is removed. Perform a Manual Trip Reset Contact Gorbel if trip persists
Watchdog	30	-	The control word has been enabled and has timed out.	Safely unload the hoist if loaded. Contact Gorbel.

Table 7-4, Continued. Trip String Indications.

Troubleshooting Tables, Continued

VFD Alarms

Alarm Name	Alarm String	Description	Motion Prevented	Solution
Braking Resistor Alarm	Braking Resistor	Braking Resistor Thermal Accumulator (Pr 00.060) in the drive has reached 75.0 % of the value at which the drive will trip. The system is warning that continued use in the current manner eventually will result in 'Braking Resistor Over Temperature' Trip.	None	Reduce down-stroke duration and/or load. Reduce duty cycle.
Motor Overload Alarm	Motor Overload	Motor Protection Accumulator (Pr.00.059) in the drive has reached 75.0% of the value at which the drive will trip and the load on the drive is >100%. The system is warning that continued use in the current manner eventually results in 'Motor Too Hot' Trip.	None	Reduce down-stroke duration and/or load. Reduce duty cycle. Reduce low frequency lift duration.
Drive Over-Temperature Alarm	Drive Overload	Percentage Of Drive Thermal Trip Level (Pr 00.061) in the drive is greater than 90%. The system is warning that continued use in the current manner eventually results in 'Oht Inverter', 'Oht Power', or 'Oht dc bus' Trips.	None	Reduce stroke duration and/or load. Reduce duty cycle.
Limit Switch Alarm	Limit Switch	The hook has reached the lowest or highest position it can travel in and one of the limit switches is active.	Upward or Downward motion	Move the hook away from the upper or lower limit.
Low AC Main Supply Voltage	Low AC	VFDs DC Bus voltage falls below specified voltage.	All motion	Check the following Cable Assemblies: 95550 & 95553 Check festooned hoist power cabling. Check AC main supply level.

Table 7-5. VFD Alarms.

This page intentionally left blank.

Hoist PCB Schematics and Interconnecting Diagrams

Refer to **Diagram 7-1**. There are four PCBs that control the functions of the GS VFD Hoist. Inspections and voltage readings are taken at various points on the other PCBs of the hoist. Refer to **Diagram 7-2** through **Diagram 7-5** for Plug/Jack locations and schematics.

WARNING!



Only trained and qualified personnel should inspect and repair this equipment.



ELECTRICAL SHOCK HAZARD!



Hazardous voltages are present in the electric chain hoist and in connections between components. **Contact with connected electrical circuits may cause death or serious injury.**



Before performing any maintenance work on the equipment, switch off and de-energize the supply of electricity to the equipment. Lockout and tag the supply device in the 'OFF' position. Refer to ANSI Z244.1 Personnel Protection- Lockout/Tag-out of Energy Sources.

Wait at least 10 minutes before opening the device.

HEAT HAZARD!



The heat generated by the GS VFD Hoist brake resistors and motor could result in serious injury or property damage. Allow the aluminum covers of the hoist to cool before touching them.

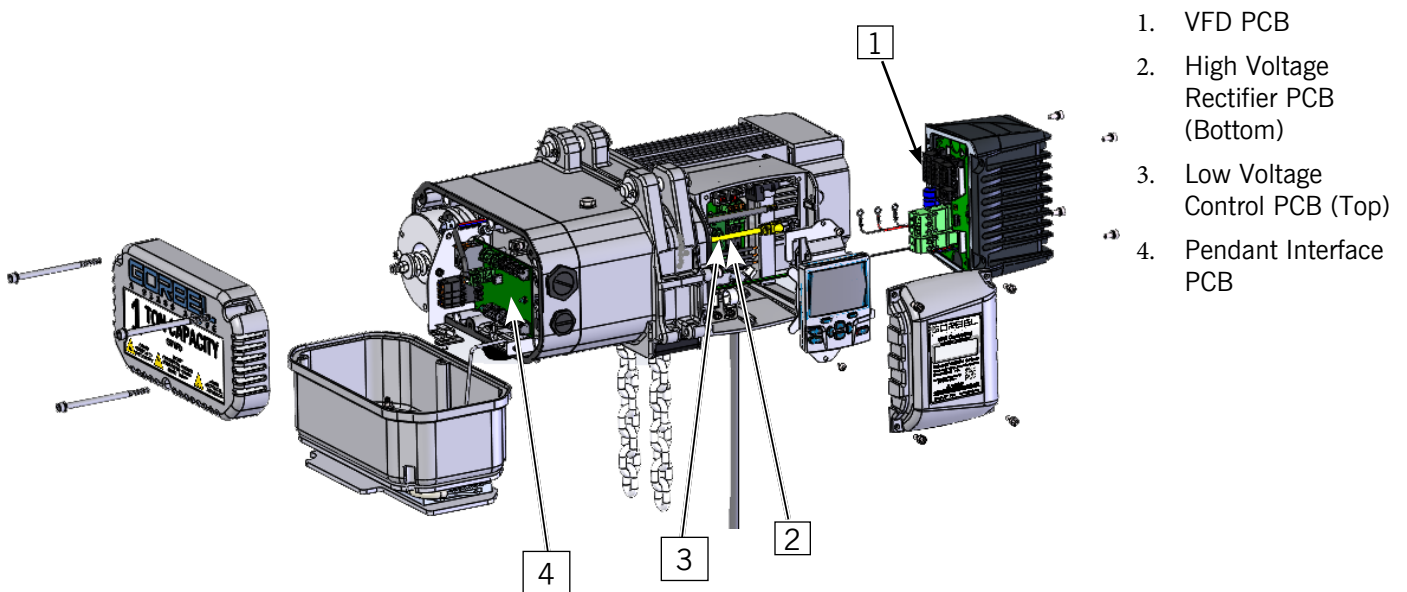
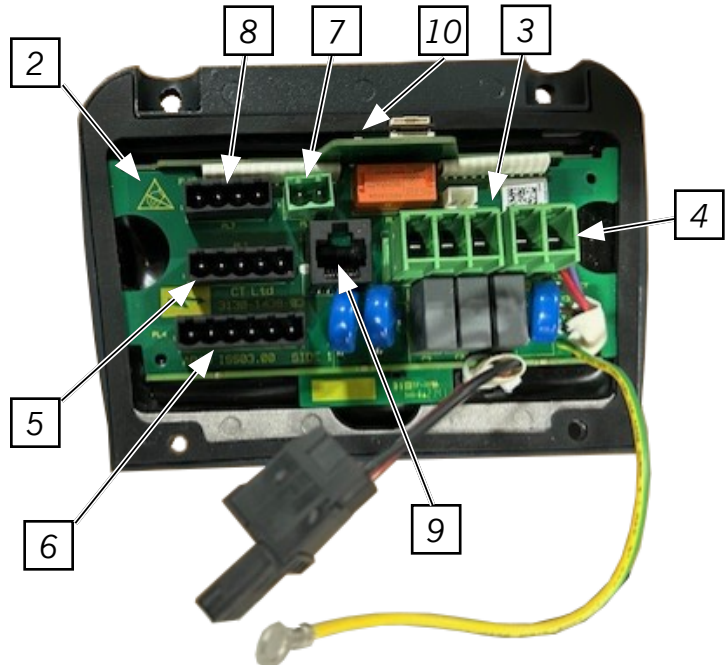
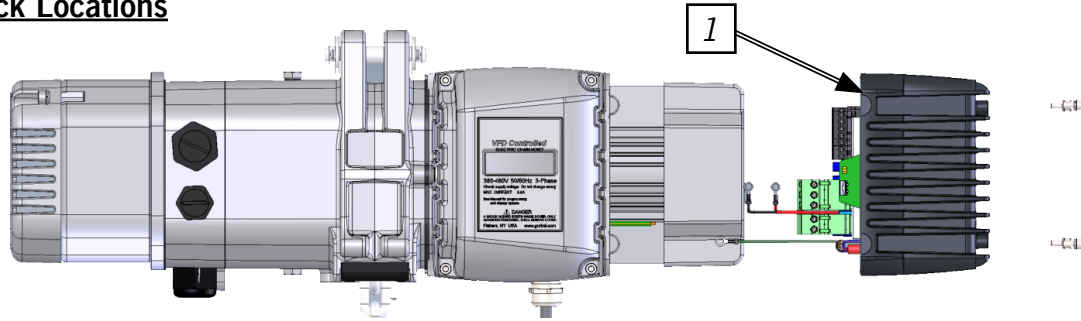

Diagram 7-1. GS VFD Chain Hoist PCBs.

Hoist PCB Schematics and Interconnecting Diagrams, Continued

VFD Plug/Jack Locations



- 1. VFD Assembly
- 2. VFD PCB
- 3. PL-1 VFD Main Power
- 4. PL-2 Braking Resistor
- 5. PL-3 VFD I/O and STO Control Signals
- 6. PL-4 VFD I/O and STO Control Signals
- 7. PL-6 VFD I/O and STO Control Signals
- 8. PL-7 VFD I/O and STO Control Signals
- 9. SK1 to Keypad
- 10. VFD Status LED

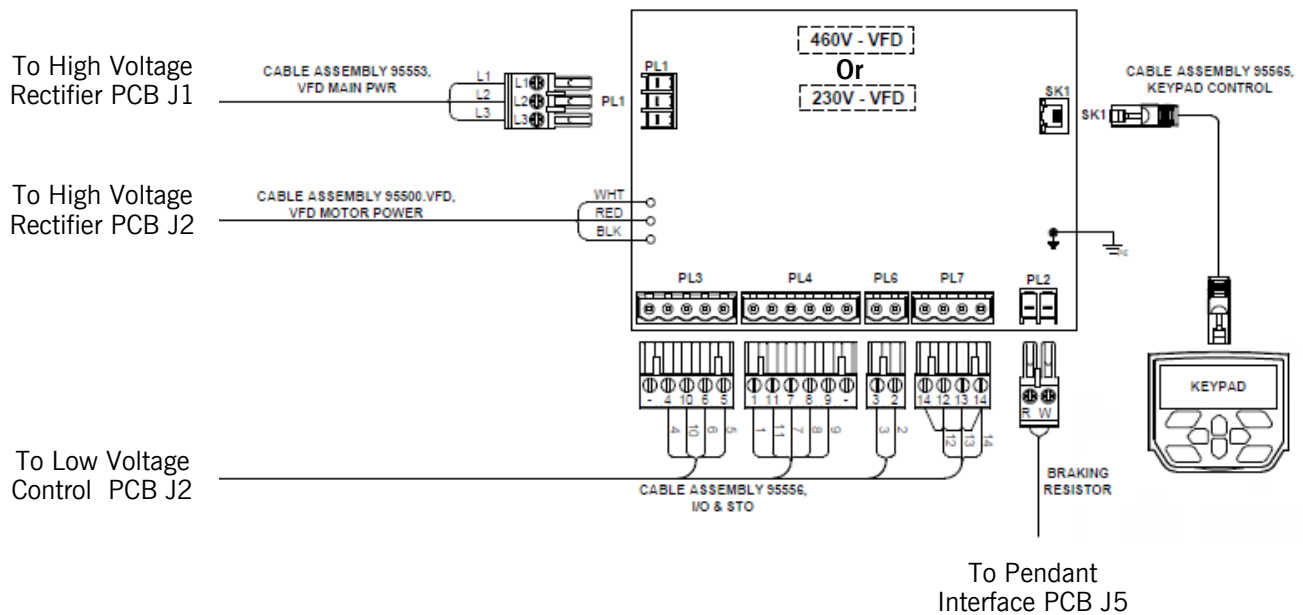
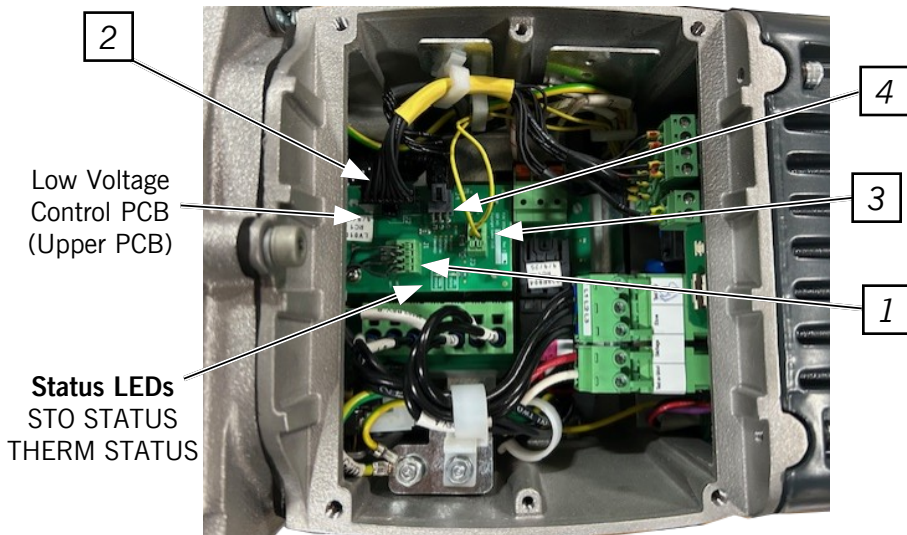

Diagram 7-2. VFD PCB and Connectors.

Hoist PCB Schematics and Interconnecting Diagrams, Continued

Low Voltage Control PCB Plug/Jack Locations



- 1. J1 - Limit Switches
 - 2. J2 - VFD Controls to VFD
 - 3. J3 - Thermal Switch
 - 4. J4 - VFD Controls from Pendant Ctrl PCB
 - 5. J5 - Brake Controls to High Volt Rectifier PCB
- 5 Bottom Surface Mount to J5 on High Voltage Rectifier PCB

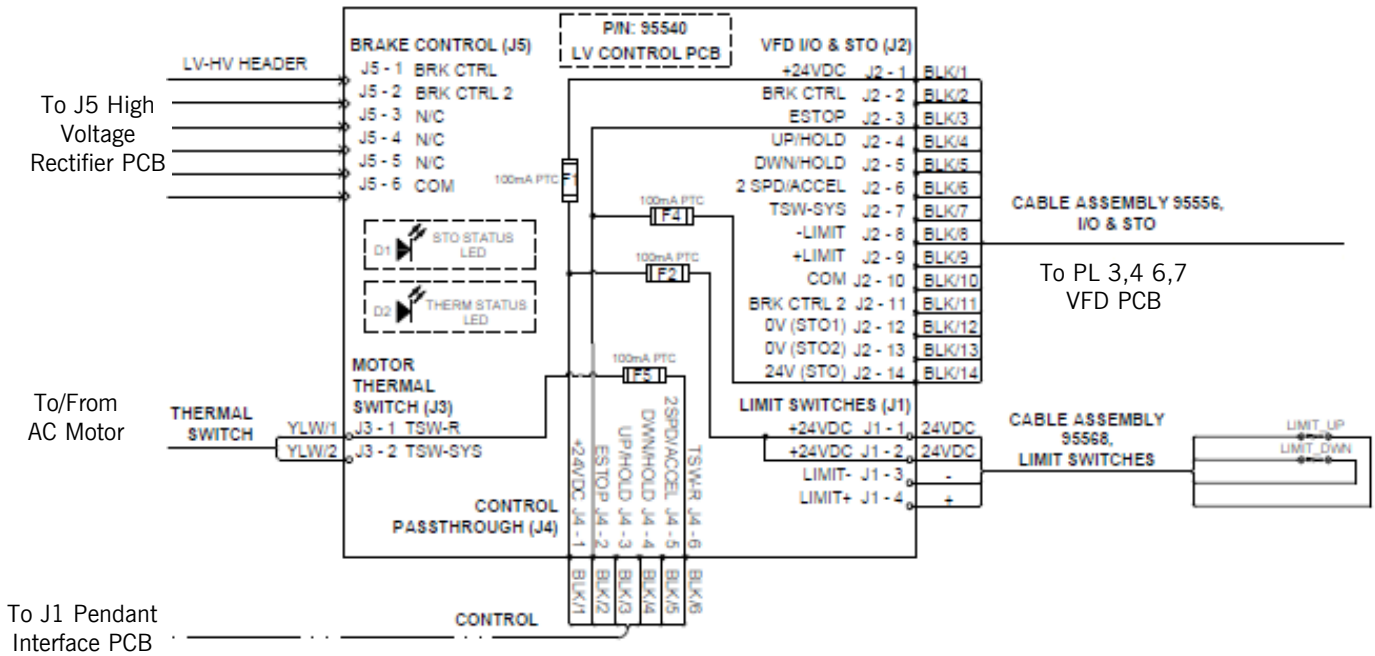

Diagram 7-3. Low Voltage Control PCB (230V or 460V).

Hoist PCB Schematics and Interconnecting Diagrams, Continued

High Voltage Rectifier PCB Plug/Jack Locations

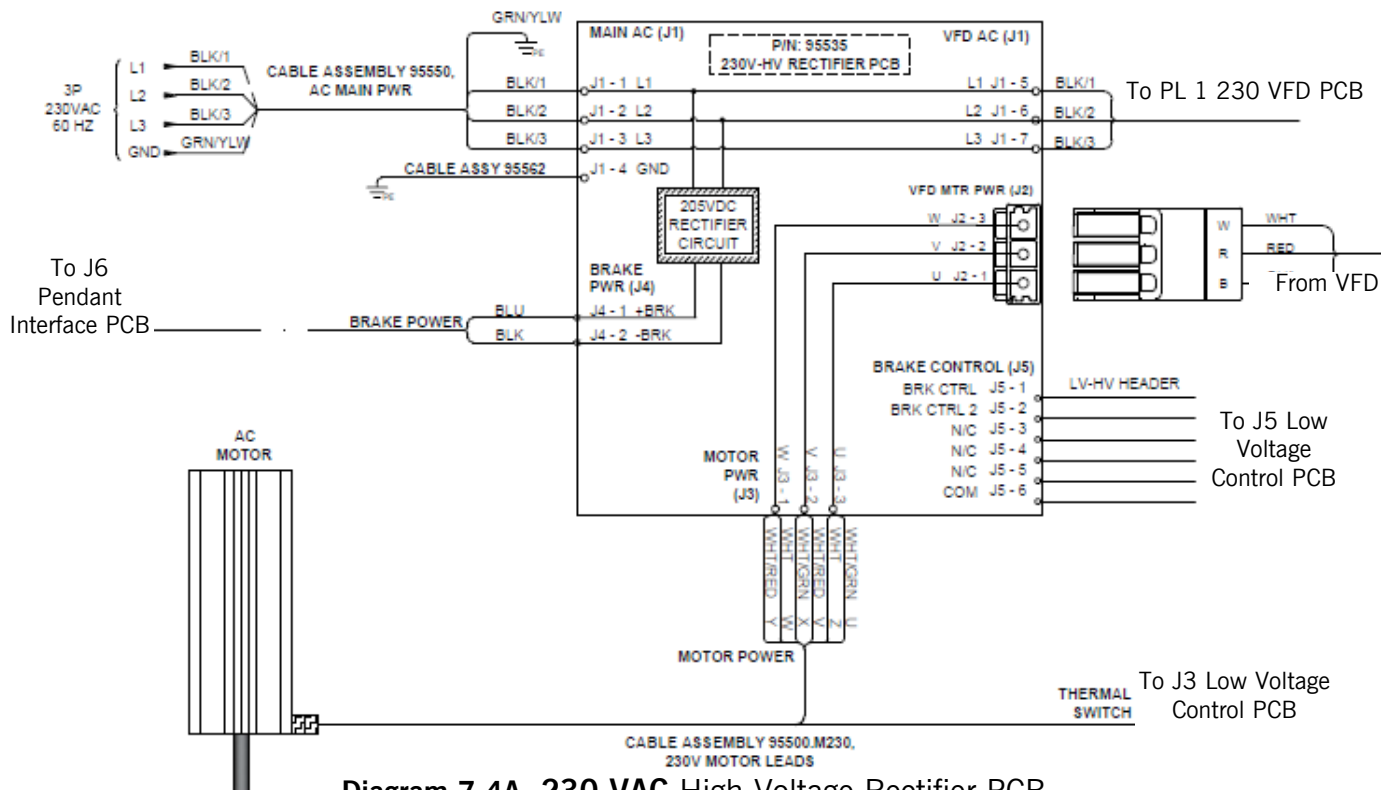
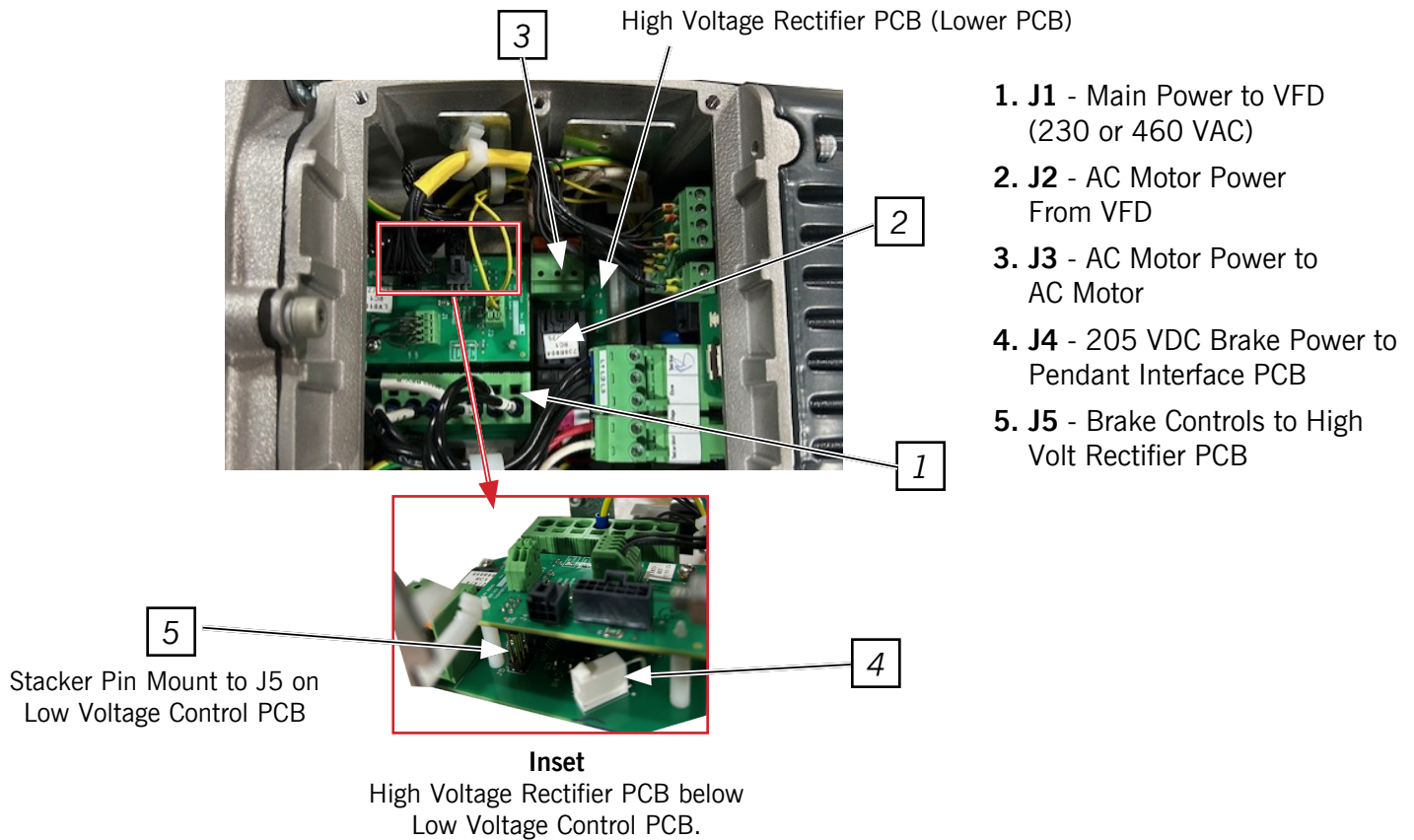

Diagram 7-4A. 230 VAC High Voltage Rectifier PCB.

460 VAC High Voltage Rectifier on the next page...

Hoist PCB Schematics and Interconnecting Diagrams, Continued

High Voltage Rectifier PCB Plug/Jack Locations, continued

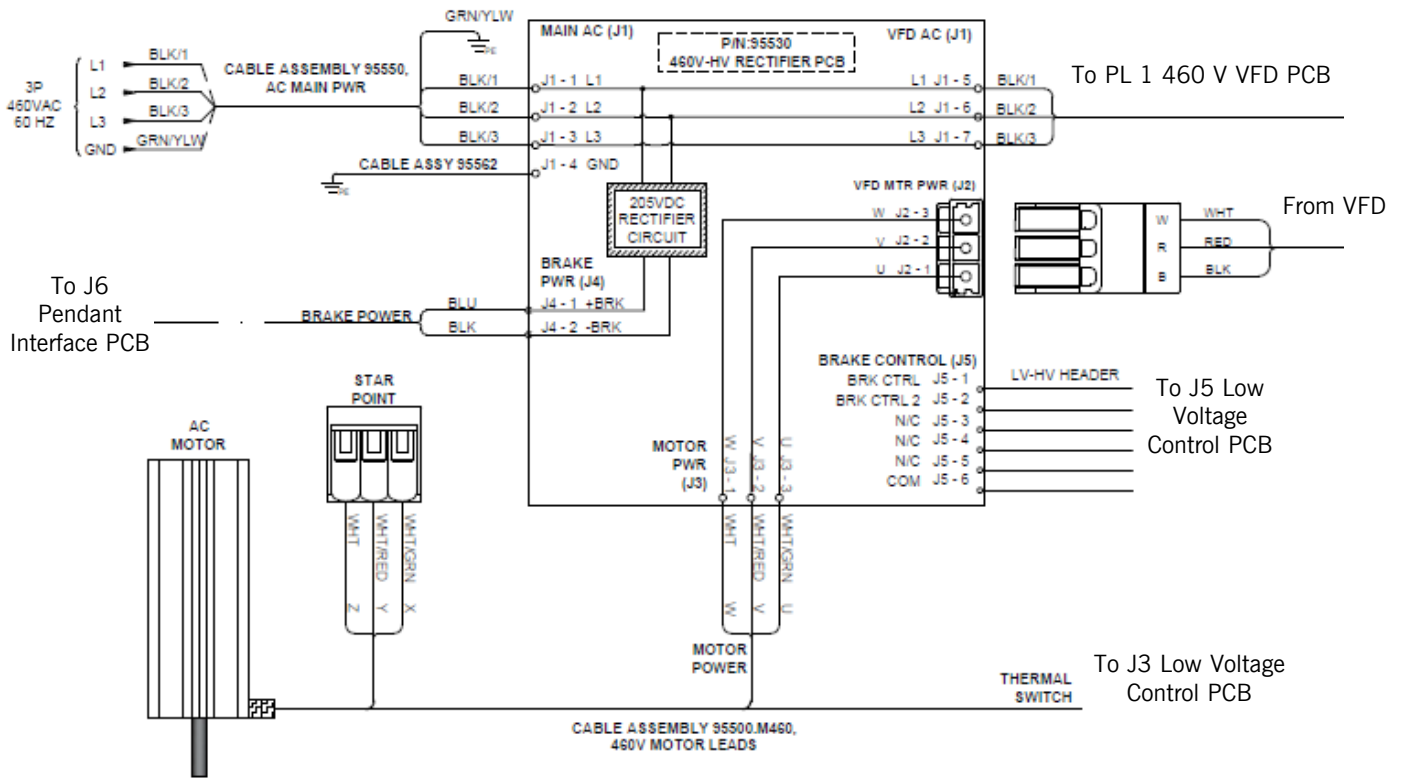

Diagram 7-4B. **460 VAC** High Voltage Rectifier PCB.

Continued on the next page...

Hoist PCB Schematics and Interconnecting Diagrams, Continued

Pendant Interface PCB Plug/Jack Locations

1. **J1** - Pendant Interface to Low Voltage Control PCB
2. **J2** - Pendant Control from Pendant
3. **J3** - Pendant Control Integration
4. **J4** - Motorized Control Integration
5. **J5** - Braking Resistor Pass-through
6. **J6** - Brake Power from High Voltage Rectifier PCB
7. **J7** - Brake Power to Brake
8. **J8** - To Braking Resistors
9. **Thermal Switch Harness** to J2 and J4.

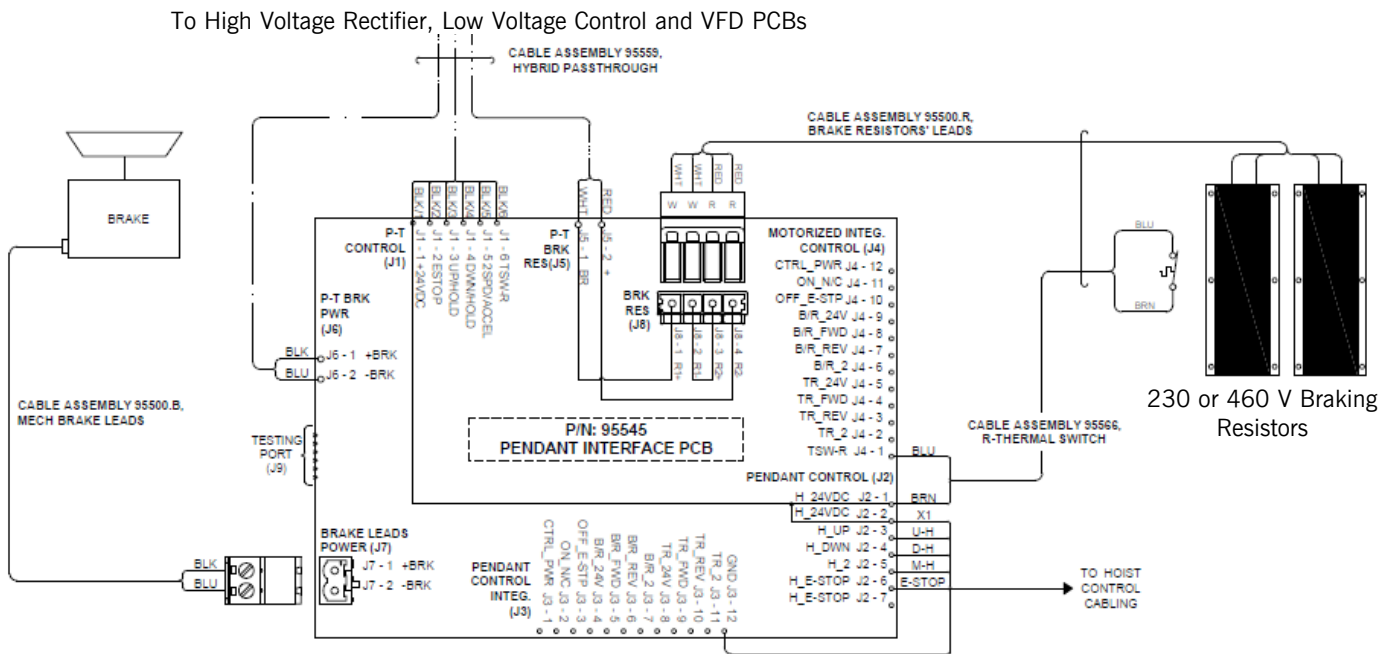
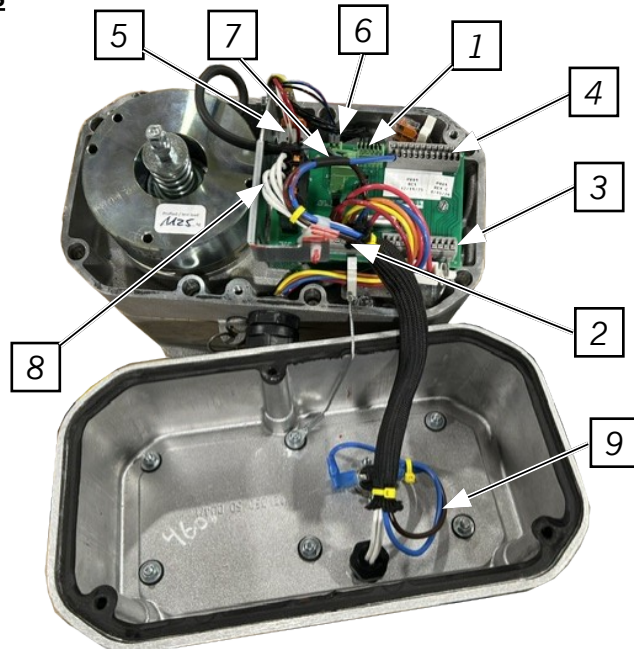

Diagram 7-5. Pendant Interface PCB Connectors.

Full Wiring Diagrams

In the next few pages, you will find **Diagram 7-6** through **Diagram 7-7** which are the fully interconnected Wiring Diagrams of the GS VFD Hoist at 230 VAC and 460 VAC.

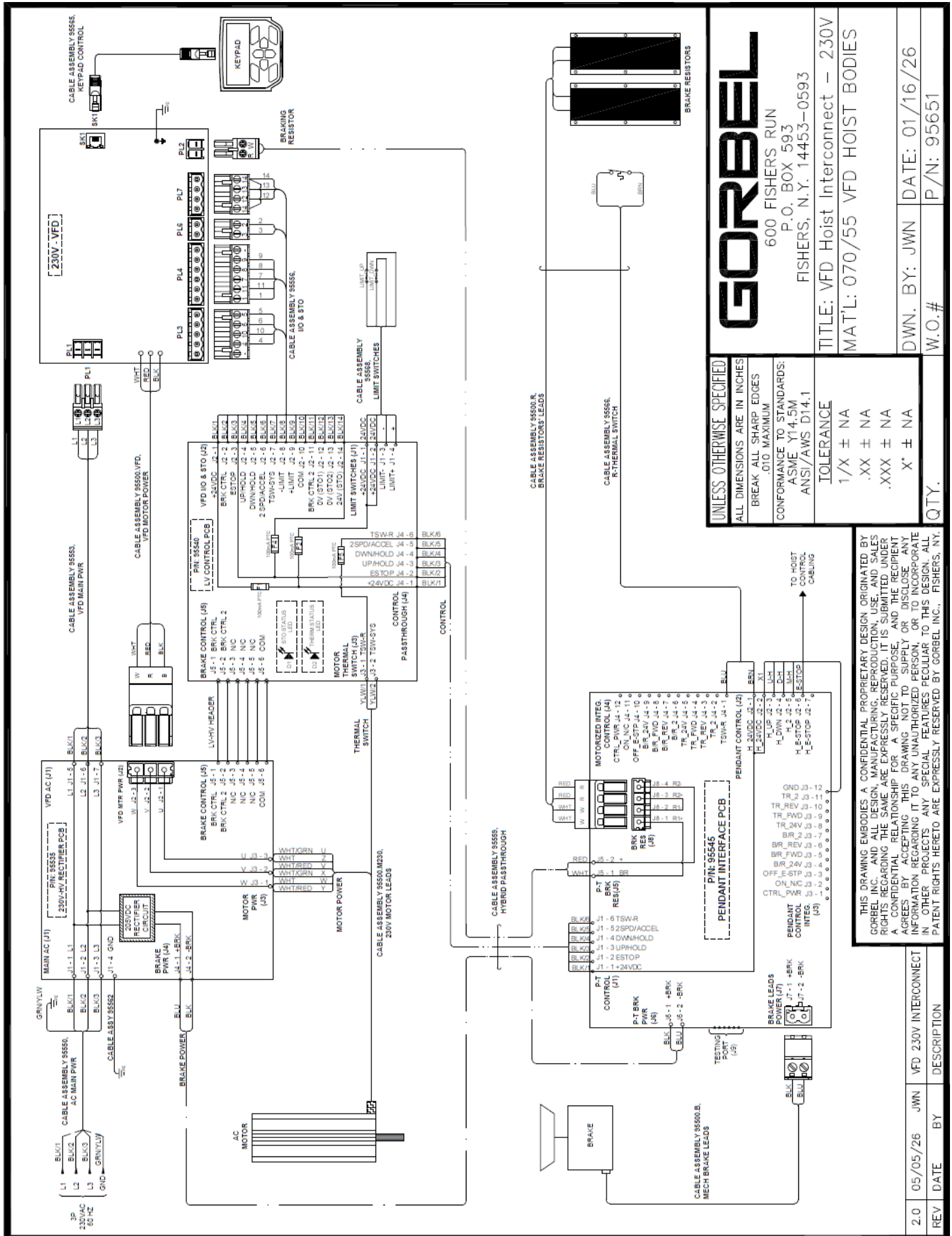
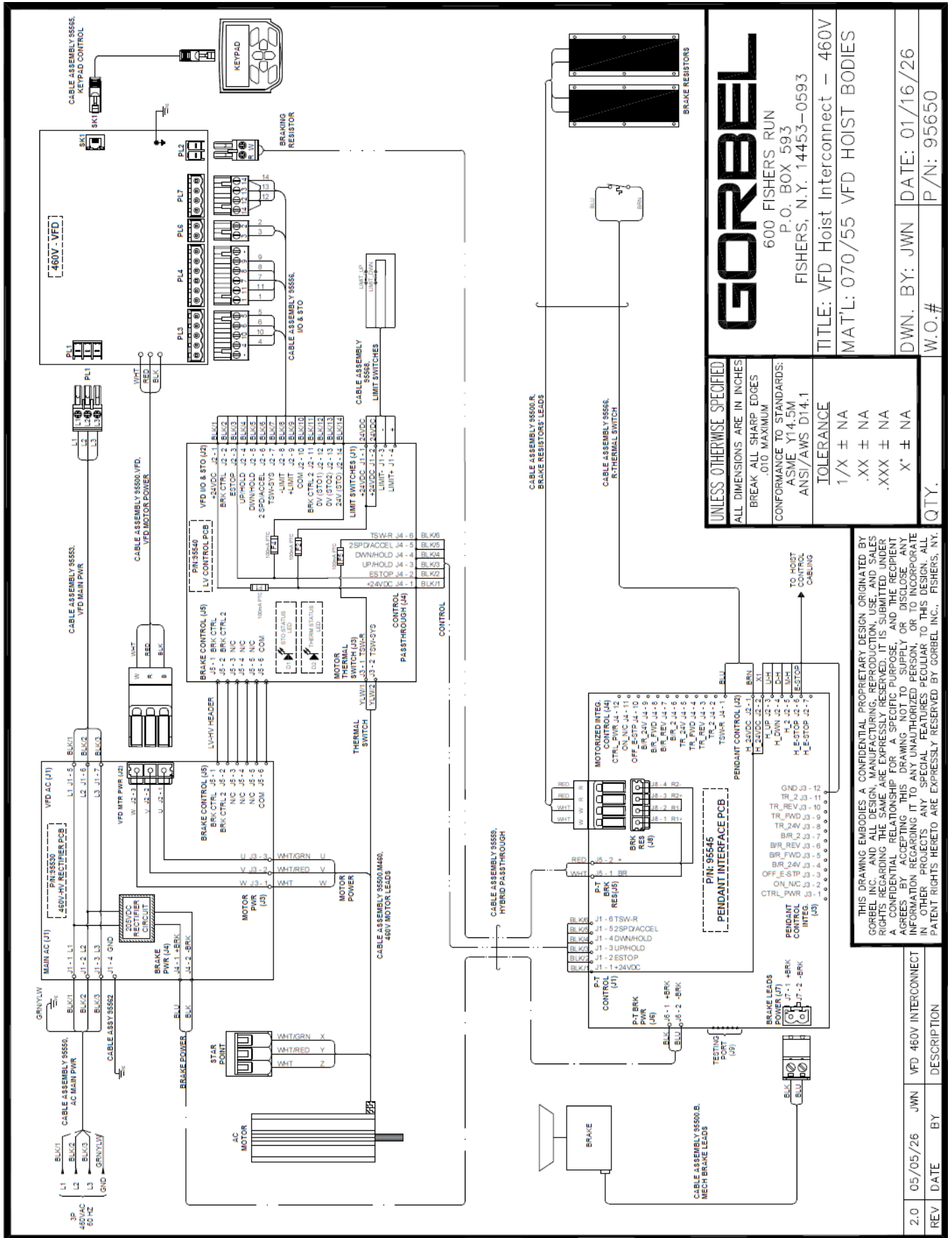

Diagram 7-6. GS VFD Hoist 230 VAC Wiring Schematic.

This page intentionally left blank.



UNLESS OTHERWISE SPECIFIED
 ALL DIMENSIONS ARE IN INCHES
 BREAK ALL SHARP EDGES
 .010 MAXIMUM
 CONFORMANCE TO STANDARDS:
 ASME Y14.5M
 ANSI/AWS D14.1

TOLERANCE
 1/X ± NA
 .XX ± NA
 .XXX ± NA
 X* ± NA

QTY.

GORBEL
 600 FISHERS RUN
 P.O. BOX 593
 FISHERS, N.Y. 14453-0593

TITLE: VFD Hoist Interconnect - 460V
 MAT'L: 070/55 VFD HOIST BODIES

DWN. BY: JWN DATE: 01/16/26
 W.O.# P/N: 95650

THIS DRAWING EMBODIES A CONFIDENTIAL PROPRIETARY DESIGN ORIGINATED BY CORBEL INC. AND IS THE PROPERTY OF CORBEL INC. NO PART OF THIS DRAWING IS TO BE REPRODUCED OR TRANSMITTED IN ANY FORM OR BY ANY MEANS, ELECTRONIC OR MECHANICAL, INCLUDING PHOTOCOPYING, RECORDING, OR BY ANY INFORMATION STORAGE AND RETRIEVAL SYSTEM, WITHOUT THE EXPRESS WRITTEN PERMISSION OF CORBEL INC. A CONFIDENTIAL RELATIONSHIP FOR A SPECIFIC PURPOSE AND THE RECIPIENT AGREES BY ACCEPTING THIS DRAWING NOT TO SUPPLY OR DISCLOSE ANY INFORMATION RELATING TO ANY UNAUTHORIZED PERSON, OR TO INCORPORATE IN OTHER PRODUCTS ANY SPECIAL FEATURES PECULIAR TO THIS DESIGN. ALL PATENT RIGHTS HERETO ARE EXPRESSLY RESERVED BY CORBEL INC., FISHERS, N.Y.

REV	DATE	BY	DESCRIPTION
2.0	05/05/26	JWN	VFD 460V INTERCONNECT

Diagram 7-7. GS VFD Hoist 460 VAC Wiring Schematic.

This page intentionally left blank.

Limited Warranty

It is agreed that the equipment purchased hereunder is subject to the following LIMITED warranty and no other. Gorbel Incorporated ("Gorbel") warrants the manual push-pull Work Station Cranes, Jib Crane, Gantry Crane, and Tether Track® products to be free from defects in material or workmanship for a period of ten years or 20,000 hours use from date of shipment. Gorbel warrants the Motorized Work Station Cranes and Jib Crane products to be free from defects in material or workmanship for a period of two years or 4,000 hours use from the date of shipment. Gorbel warrants the G-Force® and Easy Arm® products to be free from defects in material or workmanship for a period of one year or 2,000 hours use from the date of shipment. This warranty does not cover Gantry Crane wheels. This warranty shall not cover failure or defective operation caused by operation in excess of recommended capacities, misuses, negligence or accident, and alteration or repair not authorized by Gorbel. No system shall be field modified after manufacture without the written authorization of Gorbel, Inc. Any field modification made to the system without the written authorization of Gorbel, Inc. shall void Gorbel's warranty obligation. OTHER THAN AS SET FORTH HEREIN, NO OTHER EXPRESS WARRANTIES, AND NO IMPLIED WARRANTIES, ORAL OR WRITTEN, INCLUDING BUT NOT LIMITED TO THE WARRANTIES OF MERCHANTABILITY OR FITNESS FOR A PARTICULAR PURPOSE, ARE MADE BY GORBEL WITH RESPECT TO ITS PRODUCTS AND ALL SUCH WARRANTIES ARE HEREBY SPECIFICALLY DISCLAIMED. GORBEL SHALL NOT BE LIABLE UNDER ANY CIRCUMSTANCES FOR ANY INCIDENTAL, SPECIAL AND/OR CONSEQUENTIAL DAMAGES WHATSOEVER, WHETHER OR NOT FORESEEABLE, INCLUDING BUT NOT LIMITED TO DAMAGES FOR LOST PROFITS AND ALL SUCH INCIDENTAL, SPECIAL AND/OR CONSEQUENTIAL DAMAGES ARE HEREBY ALSO SPECIFICALLY DISCLAIMED. Gorbel's obligation and Purchaser's or end user's sole remedy under this warranty is limited to the replacement or repair of Gorbel's products at the factory, or at the discretion of Gorbel, at a location designated by Gorbel. Purchaser or end user shall be solely responsible for all freight and transportation costs incurred in connection with any warranty work provided by Gorbel hereunder. Gorbel will not be liable for any loss, injury or damage to persons or property, nor for damages of any kind resulting from failure or defective operation of any materials or equipment furnished hereunder. Components and accessories not manufactured by Gorbel are not included in this warranty. Purchaser's or end user's remedy for components and accessories not manufactured by Gorbel is limited to and determined by the terms and conditions of the warranty provided by the respective manufacturers of such components and accessories.

A. DISCLAIMER OF IMPLIED WARRANTY OF MERCHANTABILITY

Gorbel and Purchaser agree that the implied warranty of merchantability is excluded from this transaction and shall not apply to the goods involved in this transaction.

B. DISCLAIMER OF IMPLIED WARRANTY OF FITNESS FOR PARTICULAR PURPOSE

Gorbel and Purchaser agree that the implied warranty of fitness for particular purpose is excluded from this transaction and shall not apply to the goods involved in this transaction.

C. DISCLAIMER OF EXPRESS WARRANTY

Gorbel's agents, or dealer's agents, or distributor's agents may have made oral statements about the machinery and equipment described in this transaction. Such statements do not constitute warranties, and Purchaser agrees not to rely on such statements. Purchaser also agrees that such statements are not part of this transaction.

D. DISCLAIMER OF SPECIAL, INCIDENTAL AND CONSEQUENTIAL DAMAGES

Gorbel and Purchaser agree that any claim made by Purchaser which is inconsistent with Gorbel's obligations and the warranty remedies provided with Gorbel's products, and in particular, special, incidental and consequential damages, are expressly excluded.

E. DEALER OR DISTRIBUTOR NOT AN AGENT

Gorbel and Purchaser agree that Purchaser has been put on notice that dealer or distributor is not Gorbel's agent in any respect for any reason. Gorbel and Purchaser also agree that Purchaser has been put on notice that dealer or distributor is not authorized to incur any obligations or to make any representations or warranties on Gorbel's behalf other than those specifically set forth in Gorbel's warranty provided in connection with its product.

F. MERGER

This warranty agreement constitutes a final and complete written expression of all the terms and conditions of this warranty and is a complete and exclusive statement of those terms.

G. PAINTING

Every crane (excluding components) receives a quality paint job before leaving the factory. Unfortunately, no paint will protect against the abuses received during the transportation process via common carrier. We have included at least one (1) twelve ounce spray can for touch-up with each crane ordered (unless special paint was specified). If additional paint is required, contact a Gorbel® Customer Service Representative at 1-800-821-0086 or 1-585-924-6262.

Title and Ownership:

Title to the machinery and equipment described in the foregoing proposal shall remain with Gorbel and shall not pass to the Purchaser until the full amount herein agreed to be paid has been fully paid in cash.

Claims and Damages:

Unless expressly stated in writing, goods and equipment shall be at Purchaser's risk on and after Seller's delivery in good shipping order to the Carrier. Gorbel shall in no event be held responsible for materials furnished or work performed by any person other than it or its authorized representative or agent.

Cancellations:

If it becomes necessary for the purchaser to cancel this order wholly or in part, he shall at once so advise Gorbel in writing. Upon receipt of such written notice all work will stop immediately. If the order entails only stock items, a flat restocking charge of 15% of the purchase price will become due and payable by Purchaser to Gorbel. Items purchased specifically for the canceled order shall be charged for in accordance with the cancellation charges of our supplier plus 15% for handling in our factory. The cost of material and/or labor expended in general fabrication for the order shall be charged for on the basis of total costs to Gorbel up to the time of cancellation plus 15%.

Returns:

No equipment, materials or parts may be returned to Gorbel without express permission in writing to do so.

Extra Charge Delay:

If Purchaser delays or interrupts progress of Seller's performance, or causes changes to be made, Purchaser agrees to reimburse Gorbel for expense, if any, incident to such delay.

Changes and Alterations:

Gorbel reserves the right to make changes in the details of construction of the equipment, as in its judgment, will be in the interest of the Purchaser; will make any changes in or additions to the equipment which may be agreed upon in writing by the Purchaser; and Gorbel is not obligated to make such changes in products previously sold any customer.

Third Party Action:

Should Gorbel have to resort to third party action to collect any amount due after thirty (30) days from date of invoice, the Purchaser agrees to pay collection costs, reasonable attorney's fees, court costs and legal interest.

OSHA Responsibilities:

Gorbel agrees to fully cooperate with Purchaser in the design, manufacture or procurement of safety features or devices that comply with OSHA regulations. In the event additional equipment or labor shall be furnished by Gorbel, it will be at prices and standard rates then in effect, or as may be mutually agreed upon at the time of the additional installation.

Equal Employment Opportunity:

Gorbel agrees to take affirmative action to ensure equal employment opportunity for all job applicants and employees without regard to race, color, age, religion, sex, national origin, handicap, veteran, or marital status. Gorbel agrees to maintain non-segregated work facilities and comply with rules and regulations of the Secretary of Labor or as otherwise provided by law or Executive Order.

This page intentionally left blank.

GORBEL[®]
A C L A S S A B O V E

600 Fishers Run, P.O. Box 593

Fishers, NY 14453-0593

Phone: (800) 821-0086

Fax: (800) 828-1808

E-Mail: info@gorbel.com

<http://www.gorbel.com>

© 2026 Gorbel Inc. All Rights Reserved

