

Tether Track[®] Fold Away Systems

Installation, Operation & Maintenance Manual

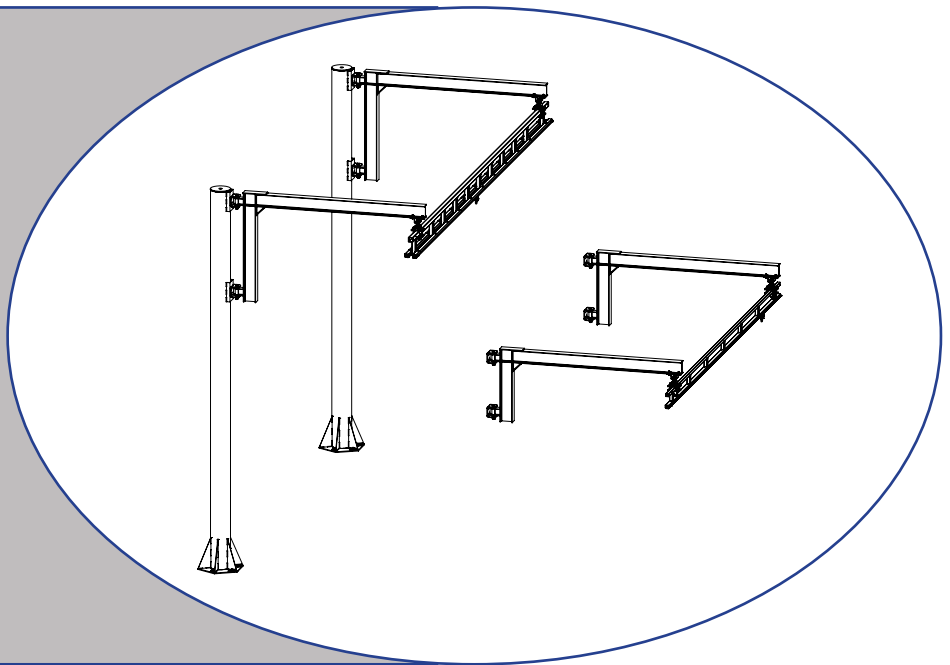

Part Number: MAN-US068-R02 Released 3/2026
Find manual updates at:
<https://www.gorbel.com/service-support/archived-installation-manuals>



Scan to Register
Your Warranty

Gorbel Customer Order No. / Serial No.

Gorbel Dealer

Table of Contents

Introduction	1
Application.....	1
Warnings	2
Restrictions.....	3
Definition of Terms.....	3
Installation.....	4
Step 1 - Pre-Assembly.....	4
Step 2 - Wall/Column Mounted Cantilever Installation	5
Step 3 - Free Standing Mast Installation.....	6
Step 4 - Free Standing Cantilever Installation	8
Step 5 - Tether Track® Installation	8
Step 6 - Trolley Installation	11
Step 7 - Friction Brake Installation (Optional)	11
Step 8 - Drive Installation (Wall Mounted) (Optional).....	14
Step 9 - Electrification Installation (Optional).....	15
Step 10 - Rotation Stop Installation (Optional).....	16
Step 11 - Final Steps	16
Fall Arrest System Requirements.....	17
Labels	19
Appendix A: Securex Friction Torque Limiter Type C & T	20
Authorized Person Instructions.....	24
General Operational Suggestions	25
Limited Warranty.....	26
Inspection and Maintenance Schedule	27

Introduction

Thank you for choosing a Tether Track® Fold Away System by Gorbel to solve your fall protection needs. Tether Track® Fold Aways have been optimally designed to provide maximum protection for workers exposed to a fall hazard. When properly applied, configured and installed under the supervision of a qualified person, Tether Track® Fold Aways will allow the ultimate in user mobility by providing a mobile rigid anchorage for the attachment of a lanyard or self-retracting lanyard (SRL). Using a SRL combined with the engineered cantilever anchorage, provides the superior safety of a rigid system by minimizing fall distance while maximizing energy absorption of the fall arrest force. This reliable performance combined with an ANSI approved Managed Fall Protection Program gives the user the utmost safety assurance and encourages further safe work practices.

Tether Track® Fold Aways are designed using ANSI guidelines and comply with all OSHA requirements for a fall arrest anchorage system. Tether Track® Fold Away systems are designed to be statically proof tested up to 110% of the average arresting force (AAF). When loaded through proof testing or during a fall event, the Tether Track® Fold Away will not incur any visual permanent deformation and may be placed back into service after performing the inspection requirements detailed in this manual. All engineered Tether Track® Fold Away systems comply with OSHA's required safety factor of 2 and are designed in accordance with ANSI Z359.6.

The W-shape cantilever design combined with a Tether Track® Monorail provide the best economic flexibility to fit your specific fall zone requirements and provide the best design to allow for the greatest fall clearance height. This along with a mobile trolley within our enclosed track allows for the maximum ease of movement. The freely pivoting hinges of the cantilevers glides this monorail system out of the way giving you the maximum flexibility of use of your overhead space. These proven designs have been utilized in Gorbel's crane products for many years. Refer to the Introduction to Jib Cranes and Introduction to Work Station Cranes for more details and additional definition of terms.

Application

Tether Track® Fold Aways are the best choice for providing coverage to a rectangular fall zone. The rigid anchorage, maintaining the anchorage trolley overhead and the use of a Self Retracting Lanyard provides the best solution to minimize fall distance when fall clearance height is restrictive. Note: specify SRL requirements at time of quote, standard design is for 900 pounds AAF. The pivoting system can be folded out of the way of overhead cranes or equipment when the system is not in use. Thrust and pull forces are provided to determine the adequacy of the available support structure. These forces are calculated using proof loading requirements of $1.10 * AAF$ and dead weight. When an existing support structure is unavailable or inadequate, Free Standing Tether Track® Fold Aways can be provided. Foundation requirements are provided based on 3000 psi concrete strength and 2500 psi allowable soil bearing strength.

When using a Tether Track® Fold Away for more than one worker and when the cantilevers are not fully extended, either the motorized or friction brake option is recommended. Both of these options, when properly adjusted, prevent excessive lateral movement of the Monorail during a fall event while limiting high lateral impact stresses in the cantilever and supporting structure.

This product meets all applicable OSHA and ANSI standard for all protection.

Dimensions contained in this installation manual are for reference only and may differ for your particular application. Please refer to the enclosed General Arrangement Drawing for actual dimensions.

Normal safety precautions: These include, but are not limited to:

- Checking for obstructions in the fall clearance zone
- Coordinating fall hazard activities with assigned rescue personnel
- Making sure that end stops are in place
- Making sure that trolley freely moves
- For Motorized Fold Aways, verifying that lock out is in place

For additional safety precautions, see page 24.

Questions? Concerns? Comments? Please call (800) 821-0086 (US and Canada) or (585) 924-6262 (outside US).

Warnings

1. Do not throw away these instructions.
2. Only competent erection personnel familiar with standard fabrication practices should be employed to assemble these anchor systems. Gorbel is not responsible for the quality of workmanship employed in the installation of an anchor system according to these instructions. Contact Gorbel Inc. at 600 Fishers Run, P.O. Box 593, Fishers, New York 14453-0593, 800-821-0086, for additional information if necessary.
3. Consult a qualified structural engineer to determine if your support structure is adequate to support the loads generated by thrust and pull (wall/column mounted) or anchor bolt force, overturning moment, or axial load (free standing) of your anchor system. Gorbel Inc. assumes no responsibility for the adequacy or integrity of mounting surface.
4. Read and understand this manual before using equipment.
5. This manual should be read and understood in its entirety, and used as part of a training program as required by OSHA or any state and local regulatory agency.
6. This and any other included instructions shall be provided to the users of this equipment. The user shall understand the proper equipment use and limitations.
7. The Tether Track® Fold Away Anchor System is only to be used as part of a complete fall protection system. The buyer or user is responsible for the safety and compatibility of the complete system.
8. Any component replacement, addition or change to the anchor system or the complete system requires evaluation by a qualified person.
9. Any fall event can result in injuries. The proper use of this equipment can substantially reduce an injury. For maximum safety, the worker shall be trained in the proper use of this equipment and all of the components of the fall arrest system.
10. Before each use, the equipment shall be inspected as outlined in the inspection section of this manual.
11. The rated capacity, the rated average arresting force, and the rated number of workers of the Tether Track® Fold Away Anchor System shall not be exceeded.
12. A managed fall protection program which includes a rescue plan is required for the safe use of this equipment. A worker suspended from this system can lose vital blood flow to the brain as blood pools in the legs. This is referred to as suspension trauma.
13. Reference the American Institute of Steel Construction (AISC) Manual of Steel Construction, Specification for Structural Joints using ASTM A325 or A490 Bolts (section 8.d.2) for the proper procedures to follow when using any torque tightening method.
14. Do not field modify the Tether Track® Fold Away Anchor System in any way. Any modifications without the written consent of Gorbel Inc. will void warranty.
15. Unless otherwise specifically stated, Gorbel® parts and products are designed for indoor use. Storing and/or using your items outside (even if covered), exposed to the elements, or in any method other than intended, may void all or some of the product warranty. Always store Gorbel® parts and products indoors, in a cool and dry area.
16. Gorbel has ensured the compatibility of Tether Track® **ONLY** with a Gorbel® approved anchor connector (fall arrest trolley). It is the responsibility of the dealer or end user to ensure proper design, function and compatibility of any trolley used with Tether Track® that has not been validated by Gorbel for a fall arrest application.
17. When using a Tether Track® Fold Away with more than one worker, a rotation restriction device should be engaged. It is recommended that a SRL with extra line be used to account for any lateral movement of the mono-rail. A leading edge fall arrest event may cause an unrestricted Fold Away system to rotate.
18. Failure to follow these instructions can result in serious injury or death.

Restrictions

1. The Tether Track® Fold Away Anchor System shall be used as part of a complete active fall arrest system. Neither Gorbel nor its distributor takes responsibility for the system as a whole. The Tether Track® Fold Away Anchor System is designed and tested by Gorbel in accordance with OSHA and ANSI Z359.1 & Z359.6 requirements using a minimum design factor of two. All components are designed in accordance with AISC guidelines.
2. The end user shall be responsible to make sure that the complete Fall Arrest System shall be designed, installed and used under the supervision of a qualified person in accordance with applicable OSHA regulations and ANSI Z359 Fall Protection Code voluntary consensus standard. State and local jurisdictions may have additional requirements.
3. It is the responsibility of the user to determine the sustainability of equipment and any attachments prior to each use and to have certification inspection on a periodic basis with recurrence not to exceed once per year by a qualified person.
4. Lanyards or self retracting lifelines (SRL) to be used with the Tether Track® Fold Away Anchor System shall have an average arresting force (AAF) equal to or less than 900 lbs or they shall have an average arresting force (AAF) equal to or less than the AAF rating of the Fold Away.
5. It is the responsibility of the end user to verify that the mounting height of this Tether Track® Fold Away Anchor System will provide adequate fall clearance when used with the customer chosen lanyard or SRL and harness.
6. Each trolley shall have no more than one person attached.
7. Trolleys are designed to freely move. To prevent a swing fall and the lengthening of the free fall distance, the user shall verify the trolley maintains the closest possible distance to the user whenever he or she changes position.
8. The Fall Clearance Zone shall be free of dangerous obstructions and electrical hazards.
9. A friction clutch (motorized) or an engaged friction brake is recommended when more than one person is using the Fold Away.
10. SRLs with reserve line are recommended to be used when more than one person is using the Fold Away system when it is not fully extended. During a leading edge fall event, the Monorail may laterally move. Extra line is recommended to prevent the second worker from being dislodged.
11. The Tether Track® Fold Away Anchor System is intended only for indoor use, unless the General Arrangement drawing indicates that this system has been specifically designed for installation and use outdoors.
12. The Tether Track® Fold Away Anchor System shall be installed per the general arrangement drawing without deviation or modification.
13. This system is not designed to be used as a crane.

Definition of Terms

AUTHORIZED PERSON - ANSI defines an authorized person as a “person assigned by the employer to perform duties at a location where the person will be exposed to a fall hazard”.

COMPLETE FALL ARREST SYSTEM - A complete fall arrest system consists of three main components:

- A. Engineered Anchor System - Gorbel’s Tether Track® has been engineered to provide the maximum safety possible. This system allows for the greatest worker mobility through Gorbel’s ergonomic enclosed track design. It provides minimal fall distance by keeping the anchor point overhead and rigid.
- B. Body Support - Only a full body harness is allowed for fall arrest systems. Proper fitting and wearing of the harness is critical so that it can evenly dissipate the fall arrest forces to the strongest body parts.
- C. Connecting Means - This is the link between the anchor and body support. A self-retracting lifeline is recommended. This provides maximum mobility and minimum fall distance. An energy absorbing lanyard may also be used. Gorbel® recommends using components suited for overhead applications where activation distance (free fall) and average arrest force are as low as possible.

FALL CLEARANCE ZONE - The space below the person where there is a potential to fall. This space must remain clear of obstructions to prevent injury from contact with any objects during a fall event.

LEADING EDGE - The edge of the working surface that a person could fall off. This edge, if located parallel with the Tether Track® Monorail, may restrict the lifeline from reaching a vertical orientation and cause off-vertical (horizontal) loading of the anchorage system. Avoid sharp leading edges or use lifelines designed to withstand a sharp leading edge fall event.

QUALIFIED PERSON - ANSI defines a qualified person as “A person with a recognized degree or professional certificate and with extensive knowledge, training and experience in the fall protection and rescue field who is capable of designing, analyzing, evaluating and specifying fall protection and rescue systems...”

Installation

Step 1 - Pre-Assembly

TIP: Packing list can be found in plastic pocket inside hardware box: General Arrangement Drawing can be found inserted in this installation manual.

- 1.1 Read entire manual **before** installing the Fold Away.
- 1.2 Check packing list to ensure no parts have been lost prior to initiating assembly.
- 1.3 Tools and materials (by others) typically needed to assemble Fold Away:
 - Torque wrench
 - Hand tools
 - Steel shims
 - Ladders/man lifts
 - Open end wrench or Allen key for clutch
 - Mounting hardware (by others, grade 5 bolts or better) for wall mounted cantilevers
 - Anchor bolts (by others, grade 5 bolts or better) for free standing fold away
 - Grout (Non-Shrink Precision Grout) for free standing fold away
 - Leveling tools and plumb bob
 - Lifting device to lift heavy masts, cantilevers and monorail(s)
 - Heavy duty drill and 3/16" bit
 - Base plate template for free standing fold away
- 1.4 Identify system type:



WARNING: Consult a qualified structural engineer to determine that your support structure is adequate to support the loads generated by thrust and pull (wall mounted) or anchor bolt force, overturning moment, and axial load (free standing) of your Tether Track® Fold Away Anchorage System.

Wall Mounted Fold Away (diagram 1A)

Refer to General Arrangement Drawing to determine thrust and pull, bracket centers, and bolt pattern and dimensions, then proceed to **Step 2**, page 5.

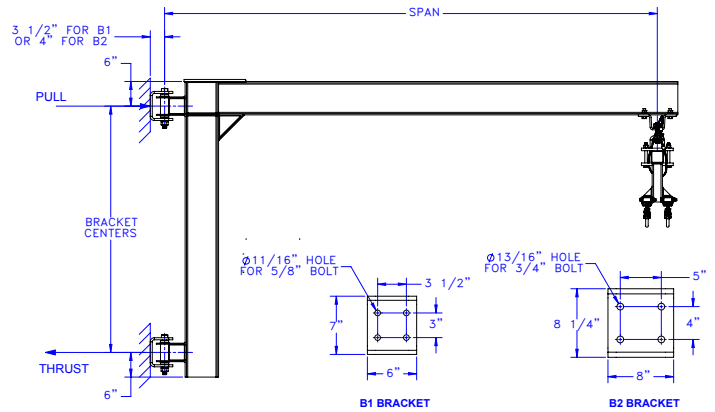

Diagram 1A. Wall Mounted Fold Away.

Free Standing Fold Away (diagram 1B)

Refer to General Arrangement Drawing to determine anchor bolt load, footer width and depth and mast size, then proceed to **Step 3**, page 6.

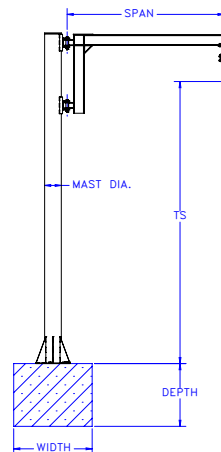

Diagram 1B. Free Standing Fold Away.

Step 2 - Wall/Column Mounted Cantilever Installation

TIP: Upper and lower formed channel (brackets) are identical unless a rotation stop is welded to the bracket. In this case, the rotation stop bracket is the upper bracket (refer to Step 10, page 16).



STOP! Do not proceed if your support structure does not meet the loading requirements determined in Step 1.4.

- 2.1 Determine position of **upper-formed** channel bracket on support structure. Drill bolt holes (see General Arrangement Drawing and **diagram 1A**, page 4, for bolt diameter and bolt to support structure).
- 2.2 Determine position of lower formed channel bracket by measuring distance between bracket centers; clamp bracket to support structure. Align brackets by dropping plumb bob (by others) through pivot holes and making sure string is centered in pivot holes (**diagram 2A**). Shim, if necessary, between mounting surface and formed channel brackets (shims by others).
- 2.3 Drill bolt holes for **lower** bracket (see General Arrangement Drawing and **diagram 1A**, page 4, for bolt diameter) and bolt to support structure. Do not torque bolts until cantilever has been checked for drift (Step 2.5).
- 2.4 Attach cantilever assembly to formed channel using hardware provided (**diagram 2B**). Be sure that thrust washers are in position. Tighten nuts on pivot bolt until lockwashers are compressed, being sure boom freely rotates.
- 2.5 Carefully swing cantilever through entire travel to ensure boom is clear of obstructions and does not drift.
If cantilever drifts, support structure may be inadequate and/or shims may be required between mounting surface and channel brackets (refer to **Step 2.2** for pivot mounting assembly alignment).
- 2.6 Torque mounting bolts (grade 5 or better, by others) to manufacturer's specifications.
- 2.7 Proceed to Step 5 on page 8.

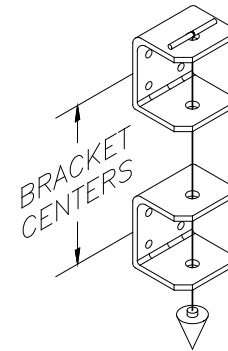

Diagram 2A. Plumbing formed channel brackets.

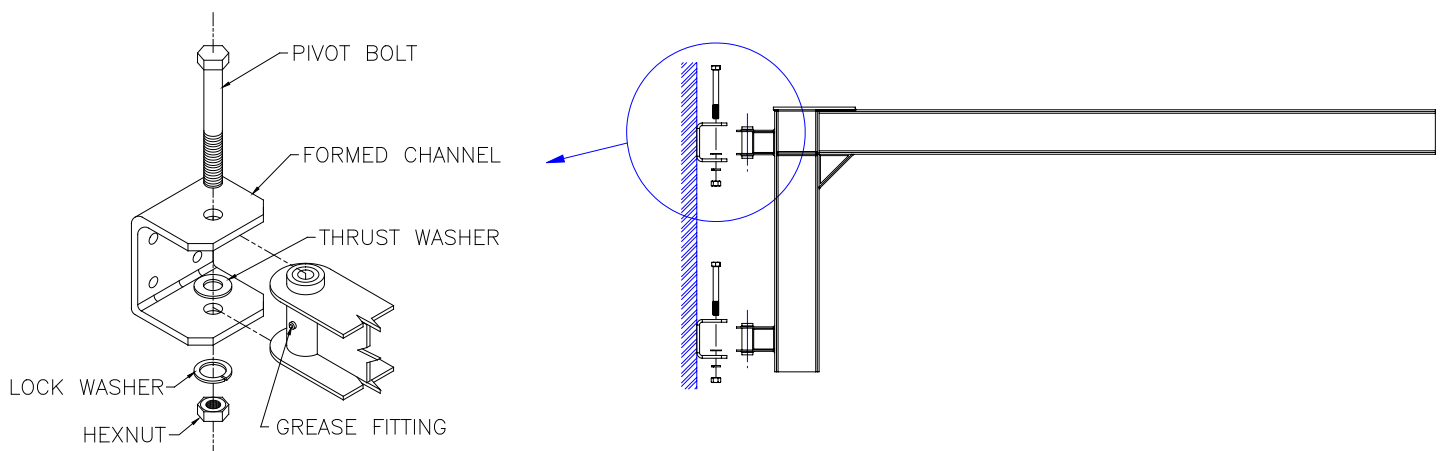

Diagram 2B. Attaching cantilever assembly to formed channel.

Step 3 - Free Standing Mast Installation



STOP! Do not proceed if your foundation does not meet the size and loading requirements identified in Step 1.4.

3.1 INSTALLING ANCHOR BOLTS

3.1.1 Refer to **diagram 3A** or **3B** and **chart 3A** for bolt hole size and pattern for base plate thickness.



WARNING: Consult a qualified structural engineer if you deviate from the recommended dimensions provided in this manual or on the General Arrangement Drawing. Gorbel, Inc. is not responsible for any deviation from these foundation recommendations.

3.1.2 Cast-in Anchor Bolts with Poured Foundations (6 or 12 bolt pattern):

TIP: Cast-in anchor bolts (J bolts) typically protrude 6" above foundation before mast is installed.

A. Anchor bolts (by others) must:

- be 1" diameter for 1-1/4" diameter base plate holes and 1-1/4" diameter for 1-1/2" diameter base plate holes.
- be embedded 3/4 of footer depth (L).
- have **minimum** of two threads above nut after installation.

B. Create steel-reinforced concrete foundation using recommendations shown in **diagram 3C**.

Refer to General Arrangement Drawing for footer depth (L) and footer width (M) in **diagram 3C**.

Note: 7/16" thick, wafer board, bolt hole templates are available to facilitate anchor bolt alignment. Foundation requirements are based on soil pressure of 2500# per square foot. Concrete pressure recommended for foundation is 3000# per square inch of compressive force.

Note: Foundation/concrete must cure seven (7) days prior to mast installation. Foundation/concrete must cure 28 days prior to using Fold Away.

C. Proceed to **Step 3.2**, page 7, for mast installation and plumbing.

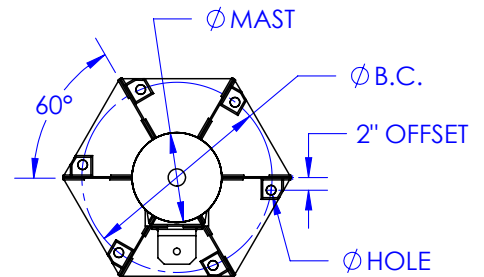

Diagram 3A. 6 bolt base bolt pattern.

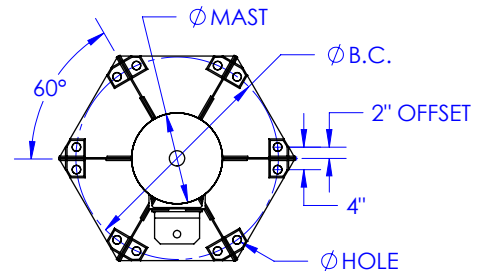

Diagram 3B. 12 bolt base bolt pattern.

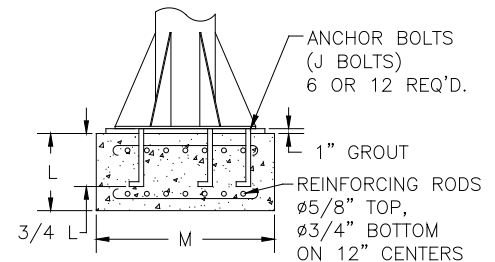

Diagram 3C. Poured foundation.

	Mast Diameter					
	8-5/8"	12-3/4"	14"	16"	18"	20"
6 Bolt or 12 Bolt Base	6	6	6	12	12	12
Diameter of Bolt Circle (B.C.)	24"	24"	30"	36"	42"	48"
Diameter of Bolt Hole	1-1/4"	1-1/2"	1-1/2"	1-1/2"	1-1/2"	1-1/2"
Hole Stiffener	No	Yes	Yes	Yes	Yes	Yes
Base Plate Thickness Including Stiffener	1/2"	1-1/4"	1-1/4"	1-1/4"	1-1/4"	1-1/4"

Chart 3A. Base plate dimensions.

3.1 INSTALLING ANCHOR BOLTS (CONTINUED)

3.1.3 Post-Installed Anchor Bolts with Shallow Foundations (6 bolt pattern):



WARNING: Shallow foundations are only appropriate for 6 foot span, one worker Fold Aways.

In addition to the requirements identified in Step 1.4, a minimum 6" thick reinforced concrete floor that is free of cracks, seams, expansion joints, and walls is required. Foundation requirements are based on a concrete compressive strength of 3000# per square inch, a soil bearing pressure of 2500# per square foot, and a modulus of subgrade reaction of 150# per square inch per inch.

- A. Anchor bolts (by others) must:
 - have an ICC-ES listing demonstrating suitability for the application.
 - be installed in accordance with the manufacturer's instructions and requirements.
- B. Base plate may be used as a template to drill holes in concrete floor. Follow anchor bolt manufacturer's recommendations for drill bit size, depth, and special inspection requirements.

Note: Base plates are designed for poured foundations. Hole size may exceed anchor bolt manufacturer's recommendations. Contact Gorbel® Customer Service if a custom base plate is required. Drill bushings or equivalent may also be used to reduce hole clearance. Bushings must not protrude above base plate. If base plate hole diameter is greater than bolt diameter plus 1/4", refer to AISC Design Guide 1 for minimum washer size and thickness recommendations.

- C. Install anchor bolts and hardware according to manufacturer's installation instructions. **Diagram 3D** shows a typical installation.

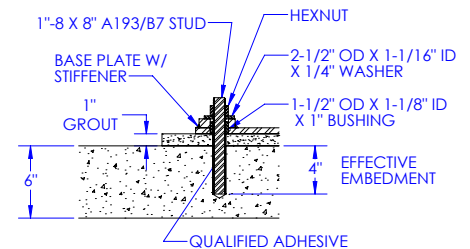

Diagram 3D. Anchor bolt installation.

Note: Before tightening hardware, follow instructions in **Step 3.2** for applying and curing grout.

3.2 Installing and Plumbing Mast



WARNING: Mast must be plumb to prevent Fold Away from drifting.

- A. Cover entire base plate area with one inch of non-shrink precision grout.
- B. Set mast into place and make sure that the base plate is completely seated in the grout.
- C. Thread a plumb line through cantilever mounting bracket holes and hole in tapered plug (by others) as shown in **diagram 3E**.
- D. Adjust mast as required until plumb line is centered in all the mounting hole brackets.
- E. Once mast is plumb **and grout has cured**, fully tighten anchor bolt hardware.
- F. Verify mast is still plumb.

DO NOT USE A LEVEL TO PLUMB MAST.

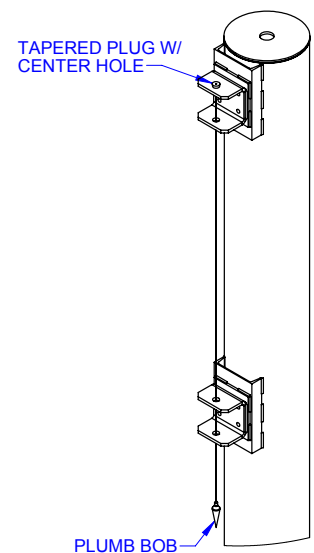
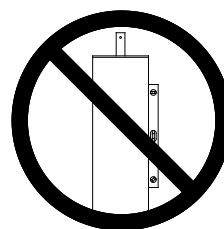

Diagram 3E. Plumbing the mast.

Step 4 - Free Standing Cantilever Installation

- 4.1 Attach cantilever to formed channel using hardware provided (**diagram 4A**). Be sure that thrust washers are in position. Tighten nuts on pivot bolt until lockwashers are compressed, being sure boom rotates freely.
- 4.2 Carefully swing cantilever through entire travel to ensure arm is clear of obstructions and does not drift.

If cantilever drifts, check to make sure mast is plumb and/or cantilever is squarely supported by both formed channel brackets. Shims may be used between thrust washer and channel bracket.

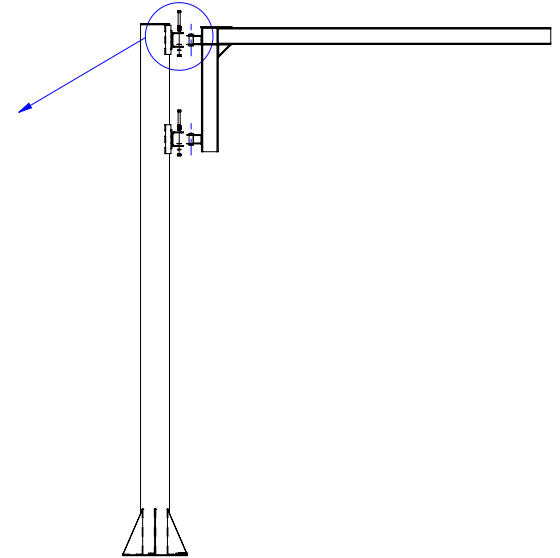
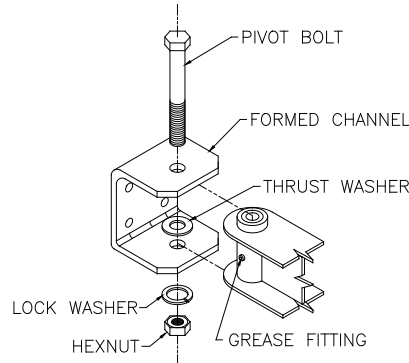

Diagram 4A. Attaching cantilever to mast.

Step 5 - Tether Track® Installation

Hanger Assemblies

- 5.1 **Note:** Remove and discard the existing setscrew from the spherical nut prior to installation. Assemble upper spherical nut on drilled end of threaded rod and align pin holes. Install roll pin. Slide threaded rod sub-assembly into upper hanger (**diagram 5A**).
- 5.2 Bolt top hanger assembly to cantilever. Assemble with hardened washer over slotted holes (**diagram 5B**) but do not fully tighten yet.

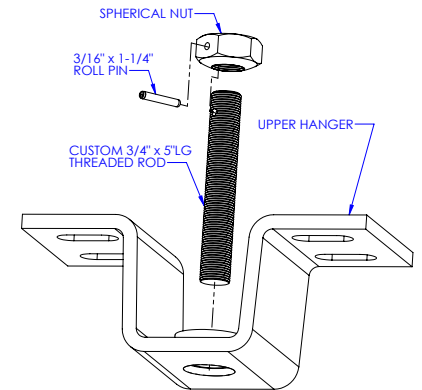

Diagram 5A. Assembling threaded rod to upper hanger.



WARNING: Bolts and threaded rod must have a minimum of two threads beyond nut.

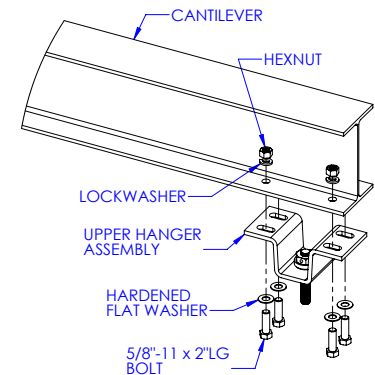

Diagram 5B. Attaching upper hanger to cantilever.

Hanger Assemblies (continued)

5.3 Bolt the lower hanger assembly and lower spine clamp plate to the top truss tube of monorail (**diagram 5C**) but do not fully tighten yet.

Monorail Installation

Note: The closer the monorail is to level and square, the better the Fold Away will perform.

Note: Track running-surface misalignment at joints shall be adjusted to within 1/32" (1mm) when installed.

- 5.4 Fully extend cantilevers so that they are parallel to each other and square with the wall/support.
- 5.5 Lift monorail into place for installation. Hangers should be aligned with 1-1/2" of clearance between them.
- 5.6 Slide threaded rod through hole in center of lower hanger assembly and thread spherical nut onto rod (**diagram 5D**).
- 5.7 Square monorail with cantilevers using slotted holes in upper hanger and sliding lower hanger along monorail top tube. When squared, torque 5/8" upper hanger hardware to 95 ft.-lbs. Tighten lower hanger hardware until lockwashers are fully compressed.
- 5.8 Level monorail by adjusting position of spherical nut on threaded rod. **Note:** Remove and discard the existing setscrew from the spherical nut prior to installation. Always leave a minimum of two threads beyond spherical nut. When leveled, use 3/16" pilot hole in nut to drill 3/16" diameter hole through threaded rod. Install roll pin through nut and rod (**diagram 5E**).
- 5.9 Wrap wire safety sling, as shown, through upper hanger and around monorail top tube. Complete safety sling loop using chain connector. Bend connector closed after threading in sling thimbles (**diagram 5F**).
- 5.10 If you do not have additional monorail sections, proceed to Step 5.12 on page 10. If you do have additional monorail section go to Step 5.11.
- 5.11 Install end stop (**diagram 5G**) (molded bumper with thru bolt), in end of monorail. For dual track, install end stops into both tracks at one end. Tighten nut on thru bolt until lock-washer is flat.

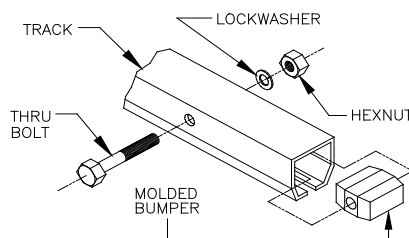

Diagram 5G. Installing end stop.

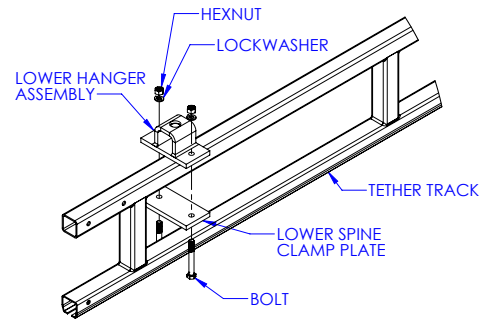

Diagram 5C. Attaching lower hanger assembly to monorail.

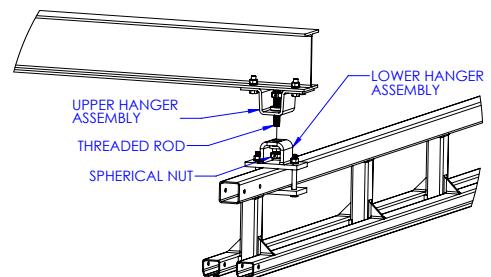

Diagram 5D. Attaching monorail to cantilever.

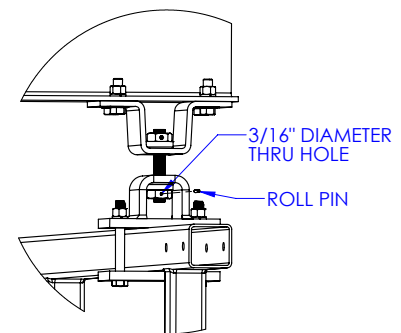

Diagram 5E. Leveling monorail.

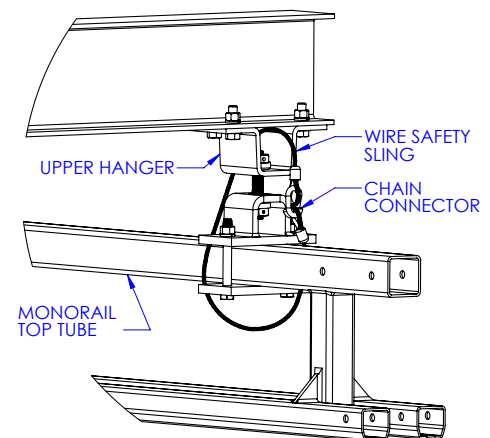

Diagram 5F. Attaching wire safety sling and chain container.

IMPORTANT: Use both the splice joint and the splice plate.

IMPORTANT: Suitable splices shall be provided at all track joints.

Splice Joint Installation



WARNING: Do not deviate from the dimensions specified in the General Arrangement Drawing for maximum space from hanger point to splice joint. This spacing must never exceed 48”.

- 5.12 Attach hardware to splice joint. Slide splice joint over track of installed monorail.
- 5.13 The maximum gap between ends of the load carrying flange shall not exceed 1/16” (1.5mm).
- 5.14 Slide next monorail section into splice joint, bringing monorail ends as close as possible (**diagram 5H** or **5J**). Center the splice joint over the track ends.
- 5.15 Place a truss splice plate on each side of runway truss tube and bolt into place (**diagram 5H** or **5J**). Tighten hexnuts but **do not torque** until you have completed Steps 5.16 and 5.17.
- 5.16 Refer to Step 5.3 on page 9 for lower hanger installation. Attach monorail to upper hanger by repeating Steps 5.4 through 5.9 on page 9.
- 5.17 **Adjust track for smooth transition:**

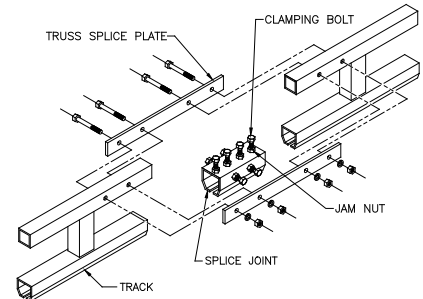

Diagram 5H. Splicing trussed track.

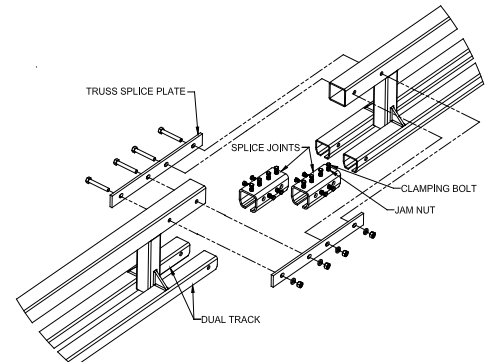

Diagram 5J. Splicing dual trussed track.



WARNING: Do not “over-tighten” clamping bolts on splice joints: this will cause permanent damage to the track. Clamping bolts are utilized for alignment purposes.

Tighten clamping bolts along the **top of splice joint** to force track down onto lower flanges of splice. Check to see that the transition from one track to the other is smooth: no raised areas to inhibit trolley or end truck operation.

Tighten clamp bolts along the **sides of splice joint** to align track laterally. Check to see that track portion of monorail is horizontally and vertically flush. Tighten jam nuts on both the top and sides of the splice joint to lock clamping bolts into place (**diagram 5H** or **5J**).

- 5.18 After you have adjusted the track for smooth transition, torque 1/2” diameter truss splice plate hardware to 50 ft.-lbs.

For Z and ZD track:

- 5.19 Refer to the General Arrangement Drawing to plan the sequence in which the monorail sections will be installed. Monorail sections that have splice plate style connections (Z and ZD styles) may need to be assembled to the mating monorail section prior to lifting and installing on the headers. Do not lift greater than two assembled (splice plate style connections only) monorail sections at a time. Do not lift assemblies greater than 54 feet long. Do not allow more than 13 feet of track to extend past the header without support. For sleeve and truss plate style connections (S, SL, SLX and SLD styles), only lift these sections individually (not assembled).



WARNING: The location of the runways cannot deviate from the location shown on the drawing. Changing the locations will void the design and the warranty.

5.20 Splice Joint Plate Style Connections: Align mating monorail sections and install hardware (**diagram 5K**). Verify track flanges (trolley wheel running surfaces) are aligned before tightening. Run a finger on the inside of the track flange and use a soft blow mallet to align plates until no lip is felt. Also check alignment of mating sections for bow and camber. Steel shims (by others) may be used between the splice plates to adjust any misalignment. Tighten hardware to 50 ft.-lbs. of torque per nut.

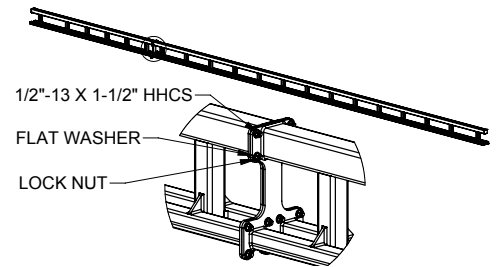

Diagram 5K. Plate style splice joint design.

5.21 For additional monorail sections repeat Steps 5.12 through 5.18.

Step 6 - Trolley Installation

- 6.1 Clean inside flanges of track with a clean, dry cloth (**do not use any kind of cleaning solution**) to remove grit or debris that may have collected during shipping, storage, or installation.
- 6.2 Be sure end stop is installed in one end of track.
- 6.3 Verify that the eyenut is securely fastened to the trolley with the spring pin installed (refer to **diagram 6A** or **6B**).
- 6.4 If using a self-retracting lifeline, attach self-retracting lifeline to trolley eye nut using ANSI approved hardware supplied with life-line. Refer to the self-retracting lifeline manual.
- 6.5 Roll trolley into open end of track.
- 6.6 Install second end stop per Step 5.11 (**diagram 5G**, page 9).
- 6.7 **(Dual Track only)** Repeat Steps 6.1 through 6.5 for second track.

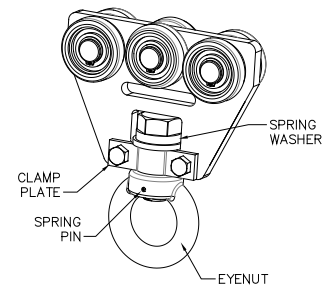

Diagram 6A. Tether Track® trolley installation.

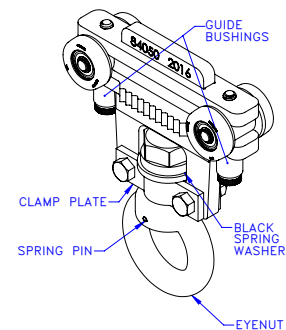

Diagram 6B. Recover trolley installation.

Step 7 - Friction Brake Installation (Optional)

Brake Caliper Installation

- 7.1 If brake caliper lever is not assembled in orientation shown (**diagram 7A**), remove cotter pin, adjuster nut, flat washer, lever mounting bolts and lock washers. Orient lever 60 degrees and reassemble.

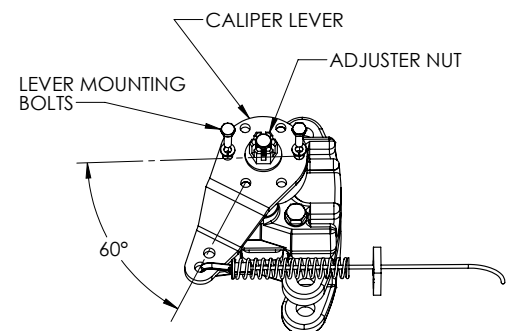

Diagram 7A. Brake caliper assembly.

7.2 Attach caliper to bracket (**diagram 7B**).

7.3 Attach spring seat to bracket. Route cable over pulley and install pulley to bracket (**diagram 7C**).

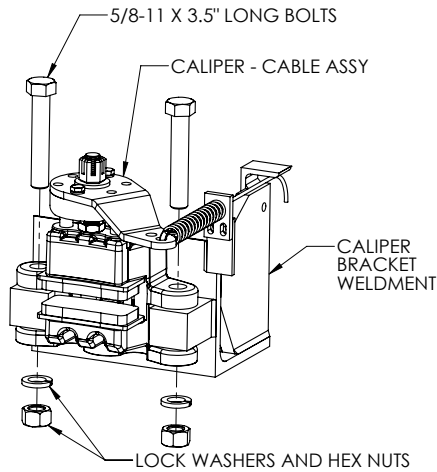

Diagram 7B. Attaching caliper to bracket.

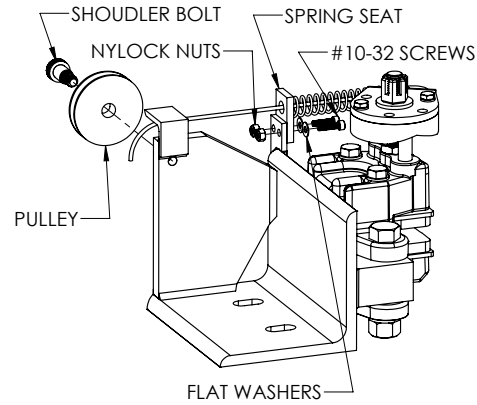

Diagram 7C. Assembling spring seat and pulley to bracket.

7.4 Using pre-drilled holes in jib, attach bracket to jib (**diagram 7D**). Alternatively, bracket may be welded to jib following step 7.6. At this time, clamp in place as follows:

- distance from bracket to end of jib top plate = 7-3/16" for 20" diameter rotor
- distance from bracket to end of jib top plate = 10-3/16" for 26" diameter rotor

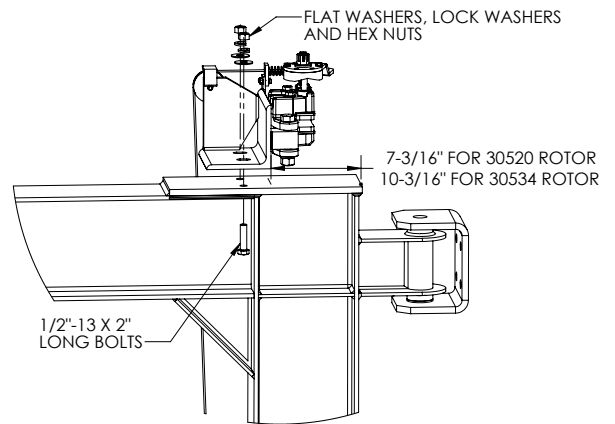

Diagram 7D. Attaching bracket to jib.

Rotor Installation

7.5 Attach brake rotor to the wall mounting bracket using three 3/8-16, 2-1/2" long hex bolts, nuts and lock washers (**diagram 7E**).

7.6 Slide rotor between brake pads as shown in **diagram 7F**. Loosen 1/2" caliper bracket mounting bolts and position caliper so that rotor overlaps brake pads by 1/16". Tighten 1/2" bolts to 50 ft.-lbs. of torque. Shims may be used on caliper and/or rotor bracket to properly align rotor and pads. Rotate boom to ensure no contact between caliper body and rotor.

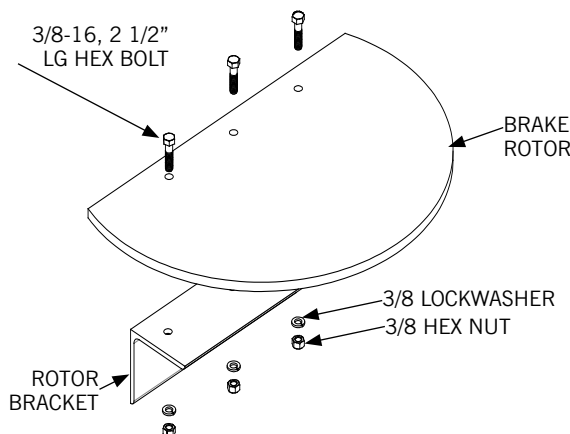

Diagram 7E. Attaching brake rotor to bracket.

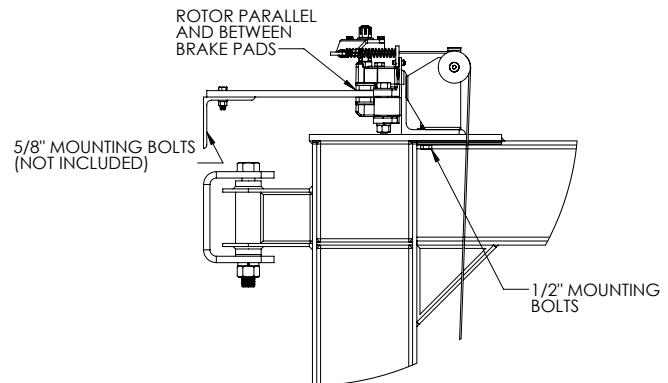

Diagram 7F. Installing rotor between brake pads.

Lever Bracket Installation

- 7.7 For beam depths 12" or less using rotor P/N 30520 and for beam depths 14" or less using rotor P/N 30534, locate lever bracket as shown in **diagram 7G**. For all other beam depths, locate lever bracket as shown in **diagram 7H**. Attach bracket to beam using 5/16" x 1-1/4" long hex bolts or weld brackets on both sides.

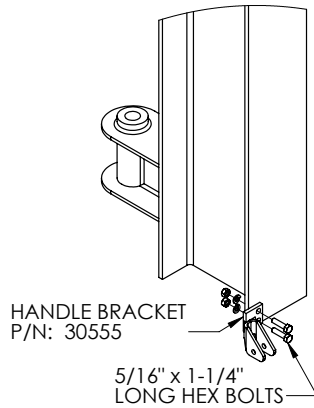

Diagram 7G. Lever bracket location.

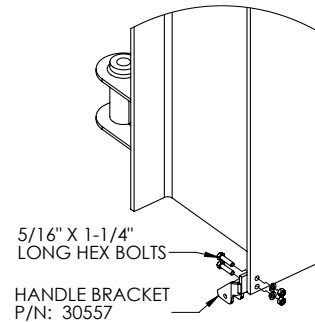

Diagram 7H. Lever bracket location.

Lever Installation

- 7.8 Attach cam to turnbuckle and to the bottom hole of the lever weldment using 5/16-18, 1.25" long hex bolt and lock nut. Use 5/16-18, 1.5" long hex bolt and lock nut to attach lever weldment to the brake release bracket. Attach pull chains to the lever weldment using hardware show in **diagram 7J**.
- 7.9 Use turnbuckle to adjust cable tension and brake release lever action. When brake is properly adjusted it requires a minimum of 40 lbs. of horizontal force applied at the end of the boom to rotate.

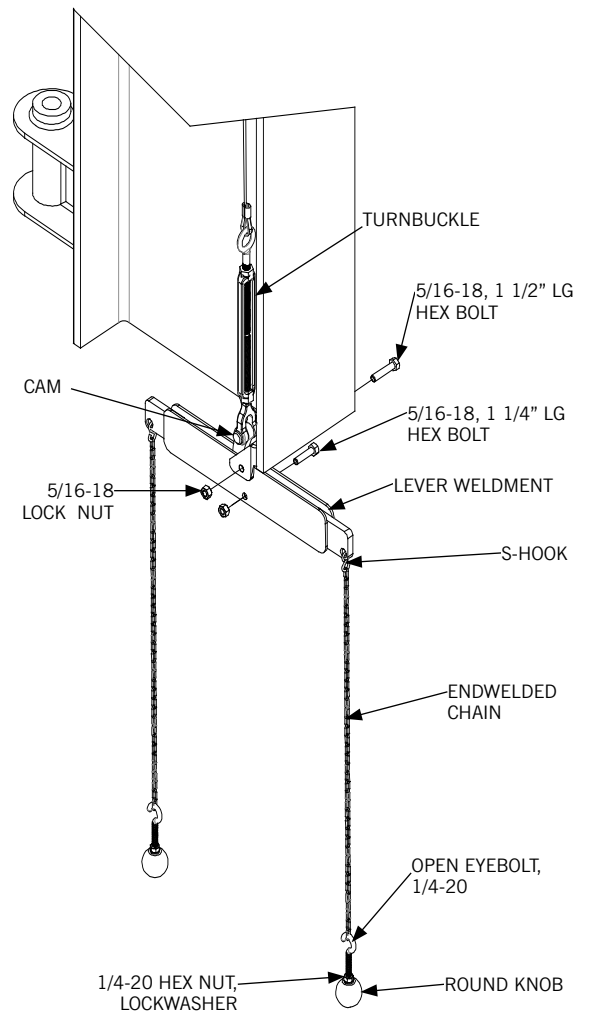

Diagram 7J. Lever installation.

Step 8 - Drive Installation (Wall Mounted) (Optional)

Holes must be drilled in wall column to mount reducer assembly (refer to General Arrangement Drawing for hole pattern, bolt size, and pattern location). Spacer plates (when required) are shipped loose.

- 8.1 The clutch is pre-tightened by Gorbel. If any additional clutch adjustment is required, refer to the friction clutch instructions below. If the clutch is not tightened properly, the lever arm may slip and the Fold Away may not rotate properly.
- 8.2 Layout reducer mounting location on support structure. Ensure that mounting surface of support structure is plumb along the plane comprising upper and lower pivot mounts and drive mount. Locate and drill holes.
- 8.3 Install cantilever according to instructions in Step 2 on page 5 or Step 4 on page 8. Hardware by others (grade 5 or better).
- 8.4 Lower drive assembly into place with lever arm engaged on pivot block and install mounting hardware (grade 5 or better, by others) but do not tighten. Verify that the drive is aligned with the axis of rotation of the cantilever and that there is approximately a 1" gap between the bottom of the lever arm and the top plate of the cantilever (**diagram 8B**). Torque drive mounting bolts (refer to **chart 8A** for proper torque rating).

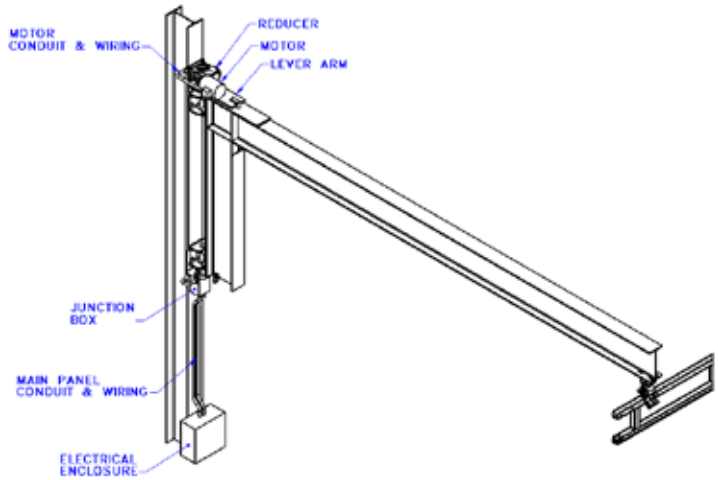

Diagram 8A. Drive installation.

Bolt Dia.	Torque
1/2"	50 ft.-lbs.
5/8"	95 ft.-lbs.
3/4"	175 ft.-lbs.
7/8"	300 ft.-lbs.
1"	450 ft.-lbs.

Chart 8A. Torque ratings.

Friction Clutch Installation

During normal operation, adjustment to compensate for friction lining wear may be necessary. The frequency of these adjustments will be dependent on the frequency of overloads occurring.

- 8.5 **CLUTCH TORQUE ADJUSTMENT - SYSTEMS USED INDOORS** Loosen the locking screw on the adjusting nut. Using the hook wrench provided, turn the adjusting nut counterclockwise until the drive sprocket can turn freely in the clutch. The clutch can now be retightened to the proper torque setting. Turn the adjusting nut clockwise until it is hand tight. Using the hook wrench provided, tighten the adjusting nut an additional two full revolutions. After the adjustment is made, tighten the locking screw to ensure that the adjusting nut doesn't loosen. The proper torque setting is achieved when the drive sprocket will not slip under normal operating conditions (**diagram 8C**).

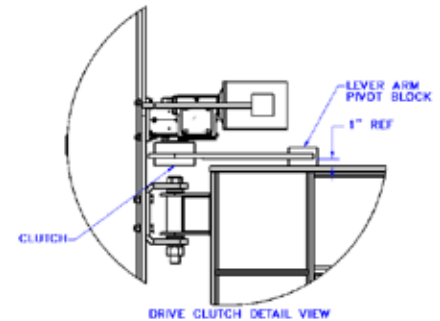

Diagram 8B. Drive clutch detail.

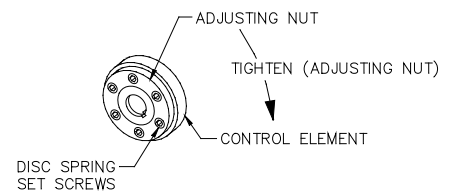

Diagram 8C. Indoor clutch torque adjustment.



STOP! If your crane was purchased prior to 2021, refer to the instructions above. For cranes purchased since 2021, go to Appendix A on page 20.

TIP: The friction clutch is shipped **pre-tightened** by Gorbel. If the clutch begins to slip during initial use, allow the clutch to slip several times then re-tighten the clutch per the instructions below. The purpose for allowing the clutch to slip several times is to establish a uniform surface on the friction linings.

Step 9 - Electrification Installation (Optional)

9.1 When ordered with a motorized Fall Arrest system, an electrical control enclosure with pendant, junction box, wire and conduit will be included (shipped loose). Hardware to mount these components is supplied by others.

9.2 Enclosure must be mounted on a rigid structure away from all moving components and within reach of user to allow access to pendant and electrical disconnect. Typically it will be mounted on same wall/structure that one of the cantilevers is located on.

9.3 Level enclosure and mount to structure (hardware by others). For hole pattern, reference **diagram 9A**. Mount junction box (hardware by others) below mast of vertical member of cantilever (**diagram 9A**).

9.4 If not already connected, wire limit switches into top of junction box (**diagram 9B**).

9.5 Connect power cable from motor to terminal in junction box. Ensure that conduit is located such that it will not be crushed by rotating cantilever.

9.6 Connect conduit and wire from junction box to main enclosure and make motor and limit switch connections.

9.7 Customer is responsible for providing incoming power to match required voltage of motor.

9.8 Reference **drawing E** and **E-1** for pendant and enclosure schematics when required.

9.9 Attach limit switch tab to bottom of vertical member of cantilever (**diagram 9C**) so that it does not interfere with the limit switch mount plate. Adjust limit switch lever arms to make contact with limit switch tab (**diagram 9D**). Position limit switches such that the Fold Away is prevented from making contact with any object and the fall zone is away from dangerous machinery or conditions. **Ensure that limit switch mounting hardware is tightened.**

Note: Limit switch should be adjusted with power supply due to deceleration once the switch has been activated.

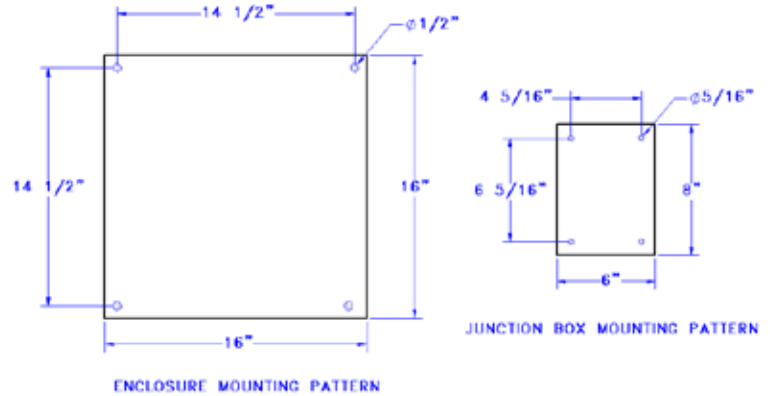

Diagram 9A. Mounting detail.

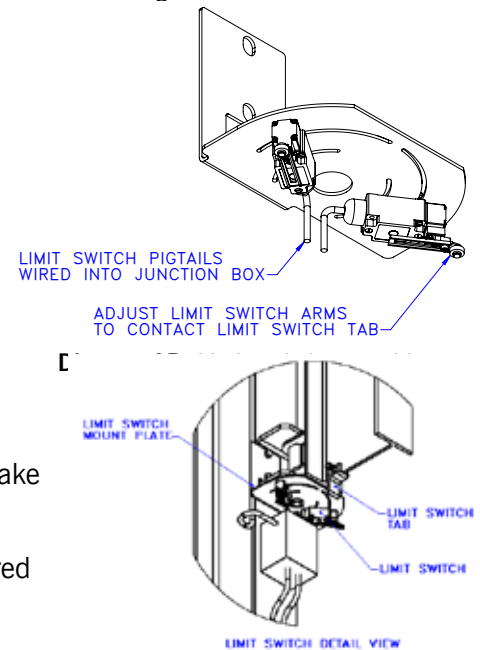

Diagram 9C. Limit switch detail.

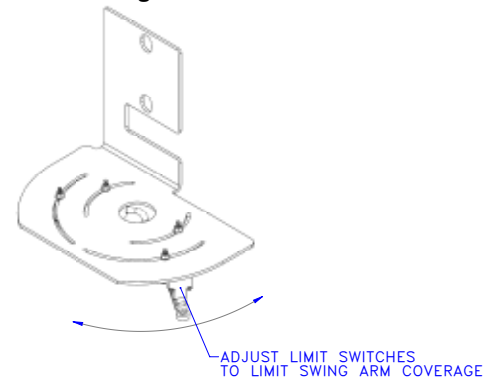

Diagram 9D. Limit switch adjustment.



WARNING: Only qualified personnel that are familiar with following local electrical codes and procedures are permitted to install these motorized systems. Gorbel is not responsible for the quality of workmanship employed in the installation of motorized assemblies.

Step 10 - Rotation Stop Installation (Optional)

- 10.1 When ordered with a rotation stop, one bracket will have a plate welded to it with slots to accept rotation stop bolts. This bracket must be installed as the upper bracket. Additionally, an angle with mounting hardware is included to be installed on the vertical member of the cantilever. Refer to **diagram 10A** for the following steps.
- 10.2 Follow cantilever installation instructions in Step 2 on page 5 or Step 4 on page 8. When tightening the top pivot bolt, use the included insert as a socket to hold the nut while tightening the bolt (a deep socket or other method may be used at the installer's discretion). Once the bolt is tight, the insert may be removed but should be kept in the event the bolt ever needs to be removed.

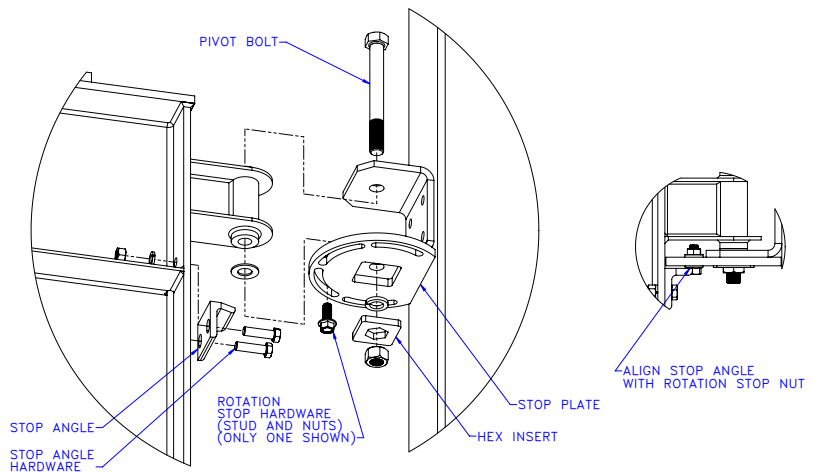

Diagram 10A. Rotation stop installation.

- 10.3 Install the rotation stop studs and nuts in the stop plate but do not fully tighten yet. Install the stop angle with included hardware and adjust vertically so the bottom of the angle is even with the top of the flange on the stop nut (**diagram 10A**). Torque hardware per **chart 8A**, page 14.
- 10.4 Locate rotation stop hardware in the stop plate such that when the nut hits the stop angle, the Fold Away is prevented from hitting any obstruction and that the fall zone is away from any dangerous machinery or conditions. Orient the nuts so the flat of the hex contacts the flat of the stop angle. Torque stop hardware per **chart 8A**, page 14.

Step 11 - Final Steps

TIP: Do not throw away this manual: the maintenance schedule is on the back cover.

- 11.1 Check to make sure all bolts are tight and lockwashers are compressed.
- 11.2 Grease all fittings (use Lubriplate #630-AA or equivalent).
- 11.3 If necessary, touch up system with paint provided.
- 11.4 Install yellow rubber tracdoms on open ends of steel track.
- 11.5 Verify capacity labels are legible from the ground or egress location.
- 11.6 For more than a one worker system or if the Tether Track[®] is to be used when not squared with the cantilevers, it is recommended that a brake or drive is installed and that only a SRL with sufficient extra payout is being used. Additional line is required to allow the Fold Away to move during a fall event without the SRL reaching its maximum length which may cause the second worker to lose his or her balance.
- 11.7 Proof testing may be performed if required by state or local jurisdictions. The qualified person responsible for this fall arrest system may also request a proof load test. The Fold Away Anchorage System has been designed to withstand a static proof load test not to exceed 110% of the rated AAF with no visible permanent deformation. The trolley shall be slowly loaded to avoid additional dynamic loads. The proof load should be applied for a minimum of one minute. After this test is complete, the Fold Away Anchorage System shall be inspected as if a fall event had occurred.
- 11.8 Keep Packing List, Installation Manual, General Arrangement Drawing, and any other inserts filed together in a safe place.

Fall Arrest System Requirements

Vertical Fall Clearance: The Tether Track® trolley will follow a worker along the length of the Tether Track® and remain overhead as long as the worker remains directly under the Tether Track®. However, as the worker moves laterally under the Tether Track®, the track will remain in place until a fall event occurs. If the Fold Away is not fully extended (track square with cantilevers), the arresting force may cause the track to move until it is over the leading edge. If a SRL is being used, the extra payout of the lifeline must be accounted for in the fall clearance calculation. The worker must never exceed a 30 degree vertical offset angle with the trolley. The extra fall clearance distance required is provided in the following calculation:

$$ODH = (TS - WS - DR) * (1/\cos\Theta - 1) \text{ (diagram 1)}$$

Where: ODH = the offset distance height required to be included in the fall clearance calculation

TS = the trolley saddle height

WS = the working surface height

DR = the lowest height of worker's harness dorsal D-ring from working surface

Θ = the vertical offset angle the worker is allowed (30 degrees maximum)

Here's a typical example:

- Worker Height (WH) = 6 ft.
- Minimum SRL Length including connectors (SL) = 2 ft.
- ANSI Z359.14 SRL, Maximum Activation and Deceleration Distance (Arrest Distance, AD) per manufacturer's labeling and instructions = 4.5 ft.
- Safety Margin used in this example (SM) = 1.5 ft.
- Working Surface Height above nearest obstruction, ground or floor in this case (WS) = 10 ft.
- Worker may be required to kneel or crouch.
- Worker is allowed to work with a vertical offset angle of 20 degrees of his or her SRL line.

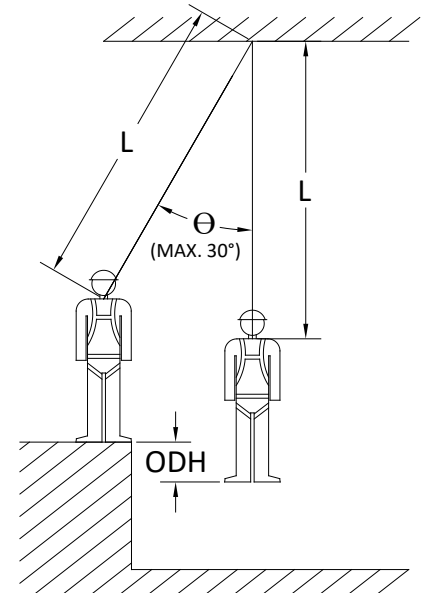

Diagram 1.

What is the lowest Trolley Saddle the Fold Away may have? SRL's typically require that there be no slack in the line (see manufacturer's specific usage requirements). To achieve this, the trolley saddle must be the minimum SRL length above the workers dorsal ring.

$$\text{Minimum TS} = WS + WH - 1 \text{ ft} + SL = 10 + 6 - 1 + 2 = 17 \text{ ft.}$$

- Here 1 ft is taken as the distance from the dorsal ring to the worker's full height.

The trolley saddle may also be calculated to limit the worker's lateral travel away from being directly under the Tether Track®. Additional information is SRL has a maximum length (SML) = 8 ft.

$$TS = WS + DR + SML * \cos\Theta = 10 + 3 + 8 * \cos(20 \text{ degrees}) = 20.5 \text{ ft.}$$

- Here 3 ft is used as the minimum height of the dorsal ring above the working surface for a worker that is crouching or kneeling (DR = 3).

Is there sufficient clearance below the working surface to arrest a fall?

$$ODH = (TS - WS - DR) * (1/\cos\Theta - 1) = (20.5 - 10 - 3) * (1/\cos(20 \text{ degrees}) - 1) = .5 \text{ ft.}$$

Required Clearance below working surface (RC)

$$RC = ODH + AD + SM + 1 + .33 + 2$$

- Here 1 ft is allowed for harness stretch, .33 ft or 4" is maximum allowed deflection for a rigid system, and 2 ft is allowed for additional leg clearance for a crouching person.

$$RC = .5 + 4.5 + 1.5 + 1 + .33 + 2 = 9.83 \text{ ft}$$

- 9.83 feet is less than 10 ft, therefore there is sufficient clearance for this application.

This example shows the importance of including the additional clearance requirements for allowing work horizontally away from the Tether Track® trolley. If the maximum allowed offset from vertical angle of 30 degrees was used, the required clearance would have exceeded the available clearance.

It is recommended to work directly below the anchorage trolley. However for some applications this may be difficult to achieve. The above calculation is identical to a swing fall calculation. However, in this case the Fold Away may move to keep the lifeline vertical instead of the worker swinging. **Note:** even with the drive or friction brake option, the Fold Away may move to the vertical lifeline position during a fall event if the system is not fully extended.

Horizontal Fall Clearance: The Fold Away, without the drive or friction brake, is designed to freely pivot so that a gently applied force will allow the Fold Away to be slowly moved into a directly overhead position.

If the Fold Away is freely pivoting and is not fully extended (track and cantilevers at 90 degrees to each other), during an offset from vertical fall, the Fold Away may slowly rotate until an obstruction is encountered or the cantilever reaches its rotation limit. If any dangerous obstructions are within the fall clearance zone, optional rotation stops are required to limit the fall clearance zone and keep it free of dangerous obstructions.

Multiple User Systems: If the Fold Away system is to be used by more than one worker in a position other than fully extended, it is recommended that the Fold Away have an optional friction brake or drive. In addition to this, SRLs with extra available line should be used. If the Fold Away is equipped with the optional drive, it must be moved into the desired position and the drive electrical enclosure properly locked out prior to anyone working at height and using this system. If the Fold Away is equipped with the optional friction brake, it must be moved into the desired position and the brake properly engaged prior to anyone working at height and using the system.

The brake and drive rely on friction to hold the Fold Away in position. In the event of a fall, the Tether Track® may move to vertically align the activated lifeline. If the Tether Track® and cantilevers are not square, additional movement may occur as the cantilevers slowly rotate. To reduce the potential of a second worker from falling, a minimum of 4 feet of extra payout line is recommended in the SRL.

It is recommended to remain directly under the Tether Track® trolley while using this Fold Away System.

Ratings: Tether Track® labels contain the following four ratings:

1. Maximum number of workers. This will typically be 1 or 2 and represents the total number of workers that may simultaneously use the Fold Away.

Note: Each Tether Track® trolley may have only one worker attached.

2. Maximum worker weight. This is limited to 310 pounds and represents the maximum combined tool and body weight of each worker. Using fall arrest equipment has an inherent risk of injury. When used properly, a SRL and a Fold Away will greatly minimize impact forces experienced by the worker. However, if there are any concerns that a user may not be able to tolerate the shock load during a fall arrest, they must not use this equipment. Concerns with exceeding this capacity are due to the higher internal forces that larger mass organs will generate and the increased risk of suspension trauma from the larger quantity of stale blood that the body must reprocess.
3. Average arresting force. The lowest average arrest force experienced by the worker is the most desirable. Maintaining the Tether Track™ trolley overhead helps minimize this. **Note:** the static proof test load is based on the average arresting force rating of the Fold Away multiplied by the maximum number of workers. Each trolley must have only one worker's AAF applied to it.
4. Maximum arresting force. This cannot exceed 1800 pounds per OSHA and ANSI requirements. During ANSI testing, this value is recorded and typically has a duration of a millisecond. ANSI testing uses a very rigid structure that is about ten times stronger than this force requires. Along with this, a rigid 310 pound test mass is used to represent a worker with tools. Due to local deformations of the support system and varying localized deceleration rates of the worker with tools, in real applications, this conservatively measured peak impulse force will be less.

Labels

Fold Away Labels



One worker Fold Away label



Two worker Fold Away label

Monorail Labels



Monorail warning label

Trolley Labels



Trolley label



Trolley warning label

Appendix A: Securex Friction Torque Limiter Type C & T Installation & Maintenance Instructions (Size 30 Thru 280)



WARNING: Read and follow all instructions carefully.



WARNING: Disconnect and lock-out power before installation and maintenance. Working on or near energized equipment can result in severe injury or death.



WARNING: Do not operate equipment without guards in place. Exposed equipment can result in severe injury or death.



CAUTION: Periodic inspections should be performed. Failure to perform proper maintenance can result in premature product failure and personal injury.



CAUTION: All electrical work should be performed by qualified personnel and compliant with local and national electrical codes.

GENERAL:

Before assembly, the pressure plates, facings, and center member (sprocket, sheave, plate, etc.) should be free of oil, grease, dirt, and rust. The center member should have a 1.6-micron finish on the area where the friction facings rub to obtain maximum rated capacity and optimum life from the Torque Limiter.

ASSEMBLY:

Refer to the appropriate sketch (see below) and assemble on the torque limiter hub the following: (A) Friction facing, (B) Bushing, (C) Center member (not shown), (D) Friction facing, (E) Pressure plate, (F) Spring(s), (G) Pilot plate (95 to 170 size models only) or (H) Lock washer (30 to 85 size models only), (J) Adjusting nut. When assembling the friction torque limiter type C, please refer to the extra notes below.

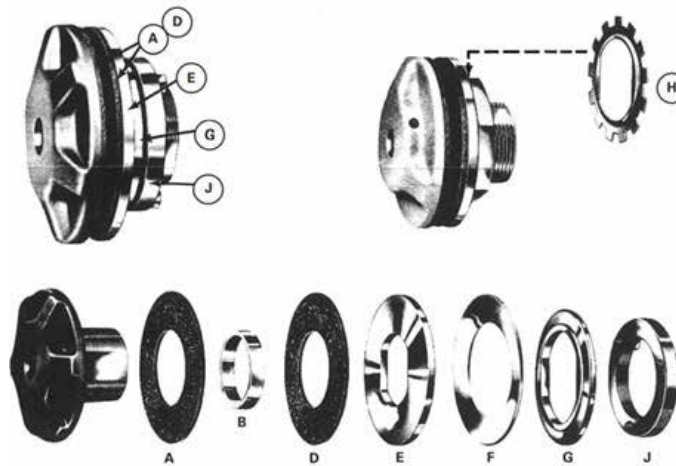

RUNNING-IN:

Torque Limiters should be run-in for the most consistent results. To run-in, adjust the Torque Limiter to 25% of the maximum single spring capacity and slip the center member approximately 50 RPM for approximately 4 minutes.

TORQUE SETTING PROCEDURES:

Type 30 ÷ 85: Loosen the locking screw (A) and tighten the adjusting nut with the proper spanner or hook wrench until a slight contact with the spring is established. Then tighten the adjusting nut further to obtain the pressure necessary to transmit the required torque without slipping. Now check if slip occurs at the required torque value and then tighten the locking screw. After the slip torque preset, the nut is locked in position by means of the appropriate locking washer.

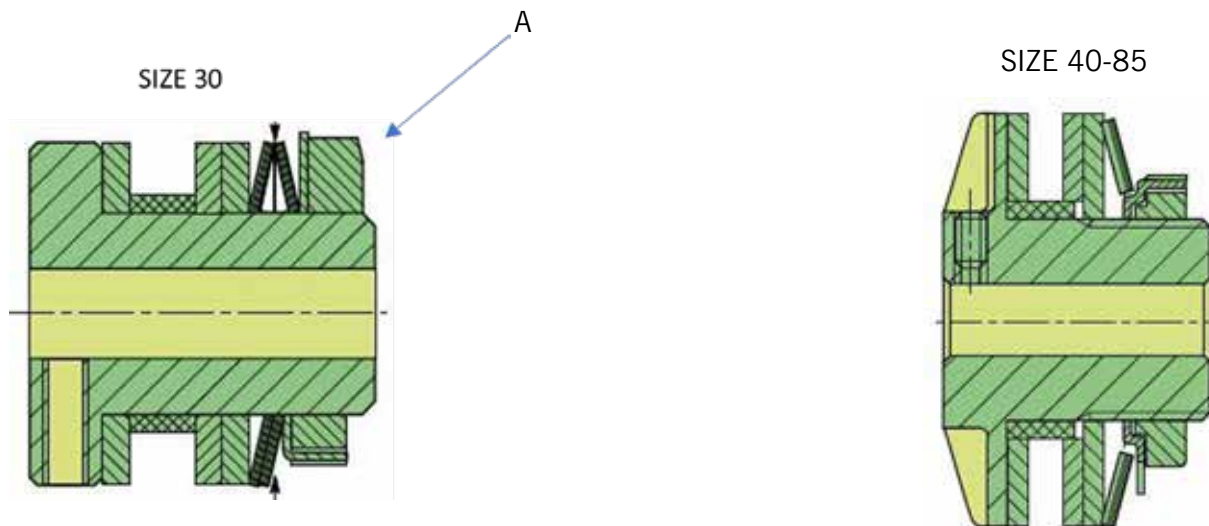

Type 95 ÷ 170: Slip torque is preset by adjustment of 4 or more screws on the nut (B), providing axial load to the disc spring. This system makes the adjustment easy. Apply springs load by loosening the adjusting bolts in approximately 60 degrees steps until no slip is observed under maximum load conditions in normal running mode. It is essential that all the bolts have equal adjustments or damage to friction facings will occur. The available diagrams give the approximate slipping torque in function of the number of turns of the adjusting bolts (the fraction refers to the number of faces of the bolts, example: 2/6 means turn 2 out 6 faces present on the bolt).

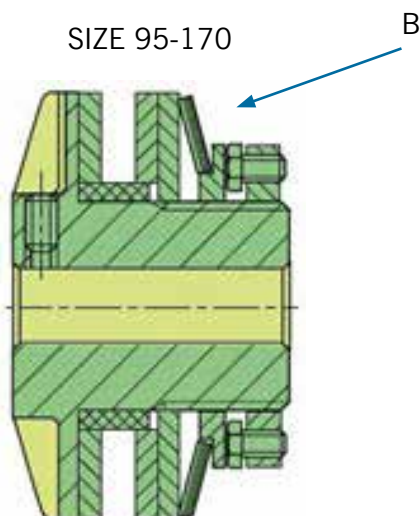

Type 200 and Up: These larger units have a series of smaller disc springs mounted on threaded holding pins which are threaded into the adjusting nut (D). Loosen the spring holding pins (C) and make pre-adjustment of the adjusting nut. Wind the adjusting nut by hand until tight against pilot plate. Ensure friction facings are concentric on the bushing and that the springs are correctly positioned on the pins.

Start tightening spring holding pins until minimal spring resistance is observed. Then, apply springs load by tightening the adjusting bolts in approximately 60 degrees steps until no slip is observed under maximum load conditions in normal running mode. It is essential that all the bolts have equal adjustments or damage to friction facings will occur. The available diagrams give the approximate slipping torque in function of the number of turns of the adjusting bolts (the fraction refers to the number of faces of the bolts, example: 2/6 means turn 2 out 6 faces present on the bolt).

Having set the torque limiter as outlined above, it is common practice to advance the bolts a further 60 degrees to prevent excess on machine start-up. Lock the nut by tightening the two screws located in it.

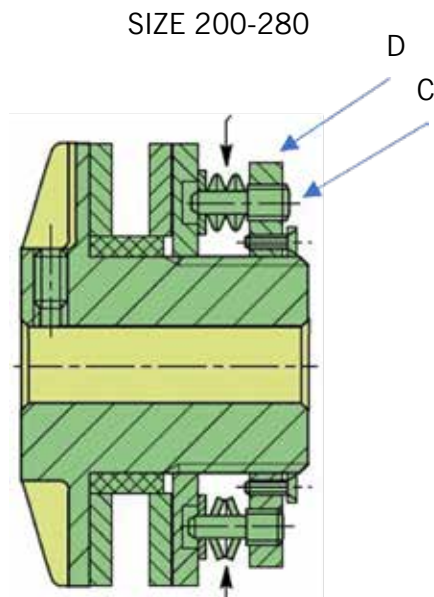

TORQUE CHECKING:

To check the Torque Limiter for the required slip torque, mount the Torque Limiter on a stub shaft and fasten in a bench vise. Wrap the center member (if a sprocket) with a chain and load the chain with weights until the center member rotates. If the center member is a plate, attach a chain or cable to the center member. The breakaway torque will be equal to the radius of the center member in feet times the weight in lbs. on the chain. The breakaway torque should be slightly higher (5% to 10%) than the required slip torque. If the slip torque is too high or too low, readjust torque limiter as per torque setting procedures above. After readjustment, check the breakaway torque in the manner outlined above and repeat adjustments if necessary.

MAINTENANCE:

The Securex series torque limiters do not normally require any maintenance. However, as with all friction torque limiters, regular inspection of the friction surfaces and other related components is highly recommended. The friction pads should be replaced when they have each worn to half of their original, new thickness. At periodic intervals, or if proper torque is not being maintained, inspect Torque Limiter for presence of oil, grease, moisture, or corrosion on the driving surfaces and for proper setting of spring load. Clean and adjust as required. Friction facings and bushings are the only parts that should normally require replacement.

CAUTION:

The operating characteristics and capacity of Torque Limiters are affected by atmospheric conditions, moisture, lubricants, and surface corrosion. To illustrate, the life of the friction facings may be greatly reduced by rust on the center plate. The Torque Limiter ratings are based on average conditions. For best results, the Torque Limiter should be adjusted under conditions like those in which it will be used.

HOW TO REPLACE FRICTION DISCS:

Please refer to the appropriate sketch (see above).

1. Remove the drive chain / belt from the torque limiter center member.
2. Loosen adjusting nut (J).
3. Disassemble all components in the following order: Remove (G) Pilot plate (95 to 170 size models only) or (H) Lock washer (30 to 85 size models only), (F) Spring(s), (E) Pressure plate, (D) Friction facing, (C) Center member (not shown), (B) Bushing and (A) Friction facing.
4. Reassemble by placing new friction discs on both sides of a new sprocket and a new sintered bushing. Please refer to the assembly instructions above.



EXTRA NOTES FOR TYPE C ASSEMBLING PROCEDURES:

When assembling type C friction torque limiter, make sure that misalignments are within the allowed values indicated below:

Tipo Type	Max. Coppia Max. Torque (Nm)	Nr. Molle Springs	Max. disallineamento Max. misalignment		N Alésaggio giunto Coupling bore		O	P	Q	R	S	T	Ingranaggio per catena Chain sprockets	
			Parallelo Parallel	Angolare Angular	Min.	Max.							N. denti Nr. teeth	Passo Pitch
C 5/30	5	2			11	22	55	37	22,5	57,1	31	1,5	16	3/8
C 10/30	10	2	0,20	30'										
C 15/40	15	1												
C 28/40	28	2	0,20	30'	8	40	55	55	25	75,2	28	2	22	3/8
C 40/40	40	3												
C 30/45	30	1												
C 55/45	55	2	0,25	30'	8	40	59,5	55	25	75,2	33	1,5	22	3/8
C 70/45	70	3												
C 70/65	70	1												
C 120/65	120	2	0,25	30'	15	48	85	70	32	106,2	50	3	18	5/8
C 130/85	130	1												
C 240/85	240	2	0,35	30'	15	60	100	90	42	138	55	3	20	3/4
C 190/95	190	1												
C 340/95	340	2	0,35	30'	15	60	110	90	42	138	66	3	20	3/4
C 350/120	350	1												
C 650/120	650	2	0,40	30'	20	80	130	120	50	183,5	77	3	20	1"
C 650/140	650	1												
C 1200/140	1200	2	0,50	30'	25	100	149	130	60	199,5	86	3	22	1"
C 1000/170	1000	1												
C 1800/170	1800	2	0,50	30'	30	100	170	158	74	231,6	93	3	26	1"
C 2200/200	2200	24												
C 4000/200	4000	24	0,50	30'	35	100	194	150	85	264	105	3	30	1"
C 3800/254	3800	32												
C 6800/254	6800	32	0,80	30'	50	150	255	230	130	390,7	120	5	36	1" 1/4
C 5500/280	5500	32												
C 10000/280	10000	32	0,80	30'	50	150	255	230	130	390,7	120	5	36	1" 1/4

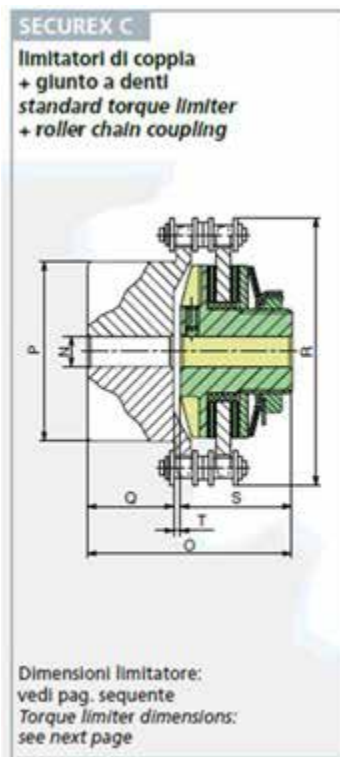

Authorized Person Instructions

Performing duties where a fall hazard exists can be dangerous. Therefore, it is important for the Authorized Person to be instructed in the use of their Complete Fall Arrest System and to understand the severe consequences of careless use. It is not intended that these suggestions take precedence over existing plant safety rules and regulations or OSHA regulations. However, a thorough study of the following information should provide a better understanding of safe use and afford a greater margin of safety. It must be recognized that these are suggestions for the authorized person working in the presence of a fall hazard. It is the responsibility of the owner to make personnel aware of all federal, state, and local rules and codes, and to make certain authorized persons are properly trained.

Qualifications

Working while being exposed to a fall hazard, to be safe and efficient, requires skill: the exercise of extreme care and good judgment, alertness and concentration, and rigid adherence to proven safety rules and practices as outlined in applicable and current ANSI and OSHA safety standards. In general practice, no person should be authorized to work while being exposed to a fall hazard:

- Who cannot speak the appropriate language or read and understand the printed instructions.
- Who is not of legal age to work while being exposed to a fall hazard.
- Whose hearing or eyesight is impaired (unless suitably corrected with good depth perception).
- Who may be suffering from heart or other ailments which might interfere with their safe performance.
- Who may be pregnant or have any condition where the exposure to the average arresting force of a fall event may be a health risk.
- Unless the person has carefully read and studied this operation manual.
- Unless the person has been properly instructed.
- Unless there is a rescue plan in place and at least one additional authorized person that has been instructed in the implementation of the rescue plan.
- Unless the person has demonstrated his or her instructions through practical use of the Complete Fall Arrest System.
- Unless the person is familiar with fall protection equipment and the safe use of this equipment.

Handling the Fold Away Motion

Before using the Fold Away Tether Track® Anchorage System, the Authorized Person needs to rotate the cantilevers until the Tether Track® will be directly over the working surface. Once in position, the Fold Away should be prevented from rotating. If the Fold Away has the optional brake installed, the brake must be engaged prior to using the Fold Away. If the Fold Away has an electrical drive, the electrical enclosure must be locked out. The cantilevers should be checked to verify they cannot be rotated. The Authorized Person should verify that the fall zone, beneath where the work is to be performed, is clear of any obstructions that would decrease the required fall clearance height. In the event of a fall, the Fold Away may slowly move until the fallen worker's lifeline is vertical. The second worker should brace himself or herself when this is noticed. The second worker's SRL should have additional line to payout so that the worker will not be tugged off balance.

Handling the Trolley Motion

Before using the trolley of the Fold Away Tether Track® Anchorage System, the Authorized Person should be sure that the trolley is clear of any obstructions that would prevent it from freely traveling along the Tether Track®. During use, the trolley should be brought into position so that it is directly over the Authorized Person. The trolley should follow the user's movement and remain overhead. Failure to keep the trolley overhead may cause a pendulum motion during a fall event that will increase fall distance and may expose the user to a side impact with any obstructions. A maximum vertical angle of 30 degrees is allowed for the Fold Away systems where the pendulum motion would be restricted by a vertical face. In this application, the leading edge of the vertical face must not be sharp enough to cause damage to the lanyard or self retracting lifeline web or cable; or an SRL specifically designed for a leading edge shall be used.

General Operational Suggestions

Know Your Environment and Your Complete Fall Arrest System

Authorized persons should be familiar with the principal parts of the Fall Arrest System and have a thorough knowledge of the safe use, inspection, and limitations of this equipment. The authorized person should be required to know the procedure to rescue a person after a fall event and be trained to rapidly implement this procedure. The authorized person(s) should be aware of any condition that may change while they are exposed to a fall hazard that may jeopardize the integrity of the fall arrest system and the rescue plan. For example, obstructions moving into a fall clearance zone.

Responsibility

Each authorized person(s) should be held directly responsible for the safe use of the Fall Arrest System. Whenever there is any doubt as to SAFETY, the authorized person should remove themselves from exposure to the fall hazard and refuse to re-expose themselves until safety has been assured. It is the responsibility of the employer to train the authorized person(s) in the safe use of the Fall Arrest System and to have managed Fall Protection in place.

Do not permit **ANYONE** to use this equipment unless they are authorized, there is at least one other authorized person within visual range, and there is a rescue plan in place.

Inspection

Test the Tether Track® Anchorage System movement and any attachments and connections before each use. Whenever the authorized person(s) find anything wrong or apparently wrong, the problem should be reported immediately to the proper supervisor and appropriate corrective action taken.

Suggestions for the use of the Tether Track® Anchorage System

The authorized person should know and follow these suggestions for safe use of this protection equipment.

1. The trolley should move smoothly and gradually as the user moves. If a self retracting lifeline is being used and the retraction tension is not great enough to move the trolley, the user should abruptly jerk the lifeline to lock it and while maintaining tension in the lifeline, the user should pull on the lifeline until the trolley is overhead. Slack should then be removed by allowing the lifeline to retract. Slack should be kept to a minimum at all times. A maximum SRL weight of 40 lbs. applies to the Recover Trolley only.
2. The trolley should be located above the user and as close to the user as possible to minimize freefall distance. The user should verify that the trolley moves as close as possible to the user whenever he or she moves. In the event of a fall, this will help to prevent swinging. The user must not work outside of the designed fall zone.
3. For Fold Away systems, lanyards and lifelines should be kept as close to vertical as possible. Offset falls will increase the freefall distance. This extra distance must be accounted for in the fall clearance calculations.
4. Be sure everyone in the immediate area is aware of your use of fall protection equipment and that the fall zone remains clear. Confirm that there is at least one person visually aware of your activities and that there is an authorized fall rescue person on-site.
5. Do not exceed the rated load capacity, number of workers, or average arresting force of the Fold Away Tether Track® Anchor System. Labels with this information are located on either side of the cantilevers and each section of the trussed Tether Track®.
6. Make certain that before exposing yourself to a fall hazard, components are properly connected, connectors are properly oriented and latches are fully closed and locked.
7. Check to be sure that all trip hazards are removed and that the fall protection zone is clear of dangerous obstructions when moving to a new location on the Tether Track® Anchor System. Be aware of the boundaries of the fall protection zone. This is detailed on your General Arrangement Drawing supplied with the manual at the time of shipment.
8. At no time should the authorized person be working alone while exposed to a fall hazard. In the event of a fall, a worker left suspended will lose the ability to circulate blood by the contractions of muscles in their legs. This combined with being suspended vertically will eventually result in lack of blood flow to the brain can lead to death.
9. Do not use equipment with unused Y-lanyard webs, straps or taglines hanging loose. These should be properly stored to prevent tripping hazards and the possibility of snagging during a fall event that may cause an excessive arresting force.
10. This equipment should not be used for any purpose other than fall protection unless it has been specifically designed for multiple purposes.
11. When multiple trolleys are being used on the same Fold Away, it is recommended the Fold Away be locked to prevent excessive rotation of the cantilevers that may dislodge a second worker during a fall event.
12. Whenever the authorized person leaves the Tether Track® Anchorage System the following procedure should be followed:
 - Verify that you are removed from the fall hazard or that you have another method of fall protection.
 - Remove your lifeline from the body harness D-ring or remove the lanyard from the trolley eye nut.
 - If using a self retracting lifeline, securely attach a tagline to the lifeline and allow it to slowly retract.
 - Remove lanyard and harness and clean any grease or dirt per manufacturer's instructions. Allow to drip dry and store in a cool, clean, dry environment out of direct sunlight.
 - Make a visual check before leaving anchor system.
 - Notify appropriate person that you are no longer using the fall arrest system.
13. After a fall event or if a safety concern is uncovered during inspection, an "out-of-service" warning sign or signal should be displayed at the access and egress point to this equipment until the system can be inspected and repaired or replaced.
14. ANY SAFETY FEATURES AND MECHANISMS BUILT-IN OR OTHERWISE PROVIDED WITH THE TETHER TRACK® ANCHOR SYSTEM BY GORBEL ARE REQUIRED FOR THE SAFE USE OF THIS EQUIPMENT. DO NOT, UNDER ANY CIRCUMSTANCES, REMOVE OR OTHERWISE IMPAIR OR DISABLE THE PROPER FUNCTIONING OF ANY SAFETY MECHANISMS OR FEATURES BUILT-IN OR OTHERWISE PROVIDED BY GORBEL FOR SAFE OPERATION OF THIS EQUIPMENT. ANY REMOVAL, IMPAIRMENT OR DISABLING OF ANY SUCH SAFETY MECHANISMS OR FEATURES OR OTHER OPERATION OF THE TETHER TRACK® ANCHOR SYSTEM WITHOUT THE COMPLETE AND PROPER FUNCTIONING OF ANY SUCH SAFETY MECHANISMS OR FEATURES AUTOMATICALLY AND IMMEDIATELY VOIDS ANY AND ALL EXPRESS AND IMPLIED WARRANTIES OF ANY KIND OR NATURE.

Limited Warranty

It is agreed that the equipment purchased hereunder is subject to the following LIMITED warranty and no other. Gorbelt Incorporated ("Gorbelt") warrants the manual push-pull Work Station Cranes, Jib Crane, and Gantry Crane products to be free from defects in material or workmanship for a period of ten years or 20,000 hours use from date of shipment. Gorbelt warrants the Motorized Work Station Cranes and Jib Crane products to be free from defects in material or workmanship for a period of two years or 4,000 hours use from the date of shipment. This warranty does not cover Gantry Crane wheels. This warranty shall not cover failure or defective operation caused by operation in excess of recommended capacities, misuses, negligence or accident, and alteration or repair not authorized by Gorbelt. No system shall be field modified after manufacture without the written authorization of Gorbelt, Inc. Any field modification made to the system without the written authorization of Gorbelt, Inc. shall void Gorbelt's warranty obligation. OTHER THAN AS SET FORTH HEREIN, NO OTHER EXPRESS WARRANTIES, AND NO IMPLIED WARRANTIES, ORAL OR WRITTEN, INCLUDING BUT NOT LIMITED TO THE WARRANTIES OF MERCHANTABILITY OR FITNESS FOR PARTICULAR PURPOSE, ARE MADE BY GORBEL WITH RESPECT TO ITS PRODUCTS AND ALL SUCH WARRANTIES ARE HEREBY SPECIFICALLY DISCLAIMED. GORBEL SHALL NOT BE LIABLE UNDER ANY CIRCUMSTANCES FOR ANY INCIDENTAL, SPECIAL AND/OR CONSEQUENTIAL DAMAGES WHATSOEVER, WHETHER OR NOT FORESEEABLE, INCLUDING BUT NOT LIMITED TO DAMAGES FOR LOST PROFITS AND ALL SUCH INCIDENTAL, SPECIAL AND/OR CONSEQUENTIAL DAMAGES ARE HEREBY ALSO SPECIFICALLY DISCLAIMED. Gorbelt's obligation and Purchaser's or end user's sole remedy under this warranty is limited to the replacement or repair of Gorbelt's products at the factory, or at the discretion of Gorbelt, at a location designated by Gorbelt. Purchaser or end user shall be solely responsible for all freight and transportation costs incurred in connection with any warranty work provided by Gorbelt hereunder. Gorbelt will not be liable for any loss, injury or damage to persons or property, nor for damages of any kind resulting from failure or defective operation of any materials or equipment furnished hereunder. Components and accessories not manufactured by Gorbelt are not included in this warranty. Purchaser's or end user's remedy for components and accessories not manufactured by Gorbelt is limited to and determined by the terms and conditions of the warranty provided by the respective manufacturers of such components and accessories.

A) DISCLAIMER OF IMPLIED WARRANTY OF MERCHANTABILITY

Gorbelt and Purchaser agree that any claim made by Purchaser which is inconsistent with Gorbelt's obligations and the warranty remedies provided with Gorbelt's products, and in particular, special, incidental and consequential damages, are expressly excluded.

B) DISCLAIMER OF IMPLIED WARRANTY OF FITNESS FOR PARTICULAR PURPOSE

Gorbelt and Purchaser agree that the implied warranty of fitness for particular purpose is excluded from this transaction and shall not apply to the goods involved in this transaction.

C) DISCLAIMER OF EXPRESS WARRANTY

Gorbelt's agents, or dealer's agents, or distributor's agents may have made oral statements about the machinery and equipment described in this transaction. Such statements do not constitute warranties, and Purchaser agrees not to rely on such statements. Purchaser also agrees that such statements are not part of this transaction.

D) DISCLAIMER OF SPECIAL, INCIDENTAL AND CONSEQUENTIAL DAMAGES

Gorbelt and Purchaser agree that any claim made by Purchaser which is inconsistent with Gorbelt's obligations and the warranty remedies provided with Gorbelt's products, and in particular, special, incidental and consequential damages, are expressly excluded.

E) DEALER OR DISTRIBUTOR NOT AN AGENT

Gorbelt and Purchaser agree that Purchaser has been put on notice that dealer or distributor is not Gorbelt's agent in any respect for any reason. Gorbelt and Purchaser also agree that Purchaser has been put on notice that dealer or distributor is not authorized to incur any obligations or to make any representations or warranties on Gorbelt's behalf other than those specifically set forth in Gorbelt's warranty provided in connection with its product.

F) MERGER

This warranty agreement constitutes a final and complete written expression of all the terms and conditions of this warranty and is a complete and exclusive statement of these terms.

G) PAINTING

Every crane (excluding components) receives a quality paint job before leaving the factory. Unfortunately, no paint will protect against the abuses received during the transportation process via common carrier. We have included at least one (1) twelve ounce spray can for touchup with each crane ordered (unless special paint was specified). If additional paint is required, contact a Gorbelt Customer Service Representative at 1-800-821-0086 or 1-585-924-6262.

Title and Ownership:

Title to the machinery and equipment described in the foregoing proposal shall remain with Gorbelt and shall not pass to the Purchaser until the full amount herein agreed to be paid has been fully paid in cash.

Claims and Damages:

Unless expressly stated in writing, goods and equipment shall be at Purchaser's risk on and after Seller's delivery in good shipping order to the Carrier. Gorbelt shall in no event be held responsible for materials furnished or work performed by any person other than it or its authorized representative or agent.

Cancellations:

If it becomes necessary for the purchaser to cancel this order wholly or in part, he shall at once so advise Gorbelt in writing. Upon receipt of such written notice all work will stop immediately. If the order entails only stock items, a flat restocking charge of 15% of the purchase price will become due and payable by the Purchaser to Gorbelt. Items purchased specifically for the canceled order shall be charged for in accordance with the cancellation charges of our supplier plus 15% for handling in our factory. The cost of material and/or labor expended in general fabrication for the order shall be charged for on the basis of total costs to Gorbelt up to the time of cancellation plus 15%.

Returns:

No equipment, materials or parts may be returned to Gorbelt without express permission in writing to do so.

Extra Charge Delay: If Purchaser delays or interrupts progress of Seller's performance, or causes changes to be made, Purchaser agrees to reimburse Gorbelt for expense, if any, incident to such delay.

Changes and Alterations:

Gorbelt reserves the right to make changes in the details of construction of the equipment, as in its judgment, will be in the interest of the Purchaser; will make any changes in or additions to the equipment which may be agreed upon in writing by the Purchaser; and Gorbelt is not obligated to make such changes in products previously sold any customer.

Third Party Action:

Should Gorbelt have to resort to third party action to collect any amount due after thirty (30) days from date of invoice, the Purchaser agrees to pay collection costs, reasonable attorney's fees, court costs and legal interest.

OSHA Responsibilities:

Gorbelt agrees to full cooperate with Purchaser in the design, manufacture or procurement of safety features or devices that comply with OSHA regulations. In the event additional equipment or labor shall be furnished by Gorbelt, it will be at prices and standard rates then in effect, or as may be mutually agreed upon at the time of the additional installation.

Equal Employment Opportunity:

Gorbelt agrees to take affirmative action to ensure equal employment opportunity for all job applicants and employees without regard to race, color, age, religion, sex, national origin, handicap, veteran, or marital status. Gorbelt agrees to maintain non-segregated work facilities and comply with rules and regulations of the Secretary of Labor or as otherwise provided by law or Executive Order.

Inspection and Maintenance Schedule

GORBEL® TETHER TRACK® FOLD AWAY ANCHOR SYSTEMS: INSPECTION BEFORE EACH USE

OSHA and ANSI require an inspection of the entire fall protection system before each use. The Tether Track® Anchor System is a vital component of the complete fall protection system. Checking for the proper functioning of this system is essential. These pre-use checks are intended to be tactile and visual.

Verify the required maintenance procedures have been properly followed. Any extreme conditions that you are aware of that may have occurred since the last maintenance procedure should be reported to the proper supervisor and an evaluation made to determine if the maintenance schedule requires modification. Some examples of extreme conditions are: a fall arrest event, excessive vibration in the system or structure, swaying of the support structure, an impact to the system or support structure, or an unauthorized person working on the system.

The previous sections, Authorized Person Instructions and General Operational Suggestions, provide important pre-use and in-use instructions and inspection guidance. The following provides a suggested checklist divided into the six main components of the Tether Track® Fold Away System. Components not listed require pre-use inspection as detailed by their manufacturers.

	YES	NO!
AUTHORIZED PERSON		
Are you authorized by your employer to perform work at height?		
Are you aware of a written procedure for the use of this equipment and does it include a rescue plan?		
Have you been trained in the use of this equipment?		
SURROUNDING ENVIRONMENT		
Is this system being used as approved by a qualified person?		
Is there adequate clearance to arrest a fall?		
Will you remain in the fall zone area allowed by this system?		
Are dangerous obstructions removed from the fall zone?		
Are nearby people aware of your pending work at height?		
Is there an authorized person within sight that has been trained in the rescue procedure?		
SUPPORTING STRUCTURE		
Is the integrity of the structure adequate?		
CONNECTIONS TO TETHER TRACK® AND CANTILEVERS		
Has scheduled maintenance been appropriately performed?		
TETHER TRACK® AND CANTILEVERS		
Is track horizontal?		
Are track and cantilevers free of deformed, bent or damaged members?		
Are endstops in place?		
Is the Tether Track® Anchor System rated for the capacity and number of people using it?		
Does Fold Away drift from desired position?		
If system has the drive or friction brake option, has it been locked in the desired position?		
TROLLEY		
Is there only one lanyard or SRL attached to the trolley?		
Is lanyard or SRL compatibly attached to trolley eyelet?		
Does trolley freely roll and remain overhead?		

If the answer to any of these questions on the checklist is no, remove yourself from the fall hazard and report the issue to the proper supervisor.

GORBEL® TETHER TRACK® FOLD AWAY ANCHOR SYSTEMS: INSPECTION AFTER A FALL ARREST EVENT

Supporting Structure (Wall Mounted)

- Inspect connections of formed channel brackets to the support. If there is any loose hardware, this may indicate that bolts have been stretched. Replace hardware if this is suspected or any damage is present.
- Inspect support structure mounting surface for damage or deformation. If there is visual damage or any reason to suspect damage, have qualified installers take the Fold Away down. Repair the damage and re-install the Fold Away.

Supporting Structure (Free Standing)

- Inspect foundation and grout for any signs of damage or cracking. Repair as required.
- Inspect mast connections to foundations. Check torque requirements per anchor bolt manufacturer's instructions.
- Inspect mast for any visual cracking in welds and/or any permanent deformation around the channel brackets and base gussets. Repair or replace as required.

Cantilevers

- Inspect formed channel brackets for deformation and cracks at formed bends. Repair or replace as required.
- Verify cantilevers freely rotate without drifting. Check pivot points for being out of plumb and shim as necessary.
- For drive option, verify normal operation. Check clutch slippage by applying a horizontal 40 pound force at the end of the cantilever. Tighten clutch as required so it does not slip at 40 pounds.
- For brake option, check rotation of Fold Away with brake disengaged. If there is any binding, check rotor and caliper mounting and adjust for clearance as required. Engage brake and check turnbuckle adjustment by applying a horizontal 40 pound force at the end of the cantilever. Adjust as required to prevent slippage.

Trolley

- Roll trolley in track listening for abnormal thumping noise. If heard, this indicates there may be debris sticking to wheel(s) or a flat spot on wheel(s) and wheel replacement is required.
- Remove endstop and carefully remove trolley from track section.
- Inspect trolley wheels for debris. Clean off if any debris is found with clean dry cloth.
- Inspect black polyurethane washer between bolt head and metal washer for deformity. If bolt head is wedged into washer, press up on eyebolt while pulling down with hands until black washer and bolt head have separated.
- Further, visually inspect trolley wheels for flat spots and/or fractures. If any are found, specific wheel replacement is necessary.
- Place trolley back into track and secure with endstop and hardware.

GORBEL® TETHER TRACK® FOLD AWAY ANCHOR SYSTEMS: INSPECTION AFTER A FALL ARREST EVENT

Tether Track®

- Inspect upper hanger connections and check torque (see Step 5.7, page 9).
- Inspect spherical nuts, hanger assemblies and threaded rod for damage. Replace as required.
- Loosen lower hanger hardware and clamping bolts at track splices (if any). This will relieve any stress and misalignment in the track that may be retained by the hardware. Ensure track sections are aligned. Re-tighten hardware per instructions in Steps 5.7 and 5.16 of this manual.
- At the location in the track where the fall arrest incident took place, measure the track opening and compare to the dimension and tolerance shown in diagram A. Replace track if measurement is not within the tolerance.
- Verify the Tether Track® has not undergone any other permanent deformation. This can be achieved by measuring the camber and bow (diagram B) of the enclosed track member and the top tube member.
 - Using a string (kite), two clamps, and a measuring device (ruler, tape measure, etc.), measure from support to support (covering track area where arrest took place).
 - Clamp one end of string to the concave face of track, at the support. Travel to the other support pulling the string taut, not allowing it to sag, and clamp it in same location on track at the support.
 - Measure the distance from the string to the track face where the distance is greatest (usually at mid-span).
 - If this measurement is greater than $.125'' \times \text{length of track in feet between supports} / 10'$ then replacement of track section is required.
 - Repeat this for both bow and camber of both enclosed track member and top tube member.
 - If arrest took place on cantilevered portion of track, measurement will be from end of track to first support.
- Visually inspect endstops for fractures or deformation, replace if any are found.



WARNING: All other components are to be inspected per their manufacturer's instructions.

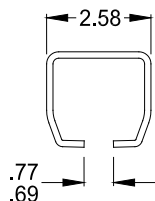

Diagram A. Track Opening Specification.

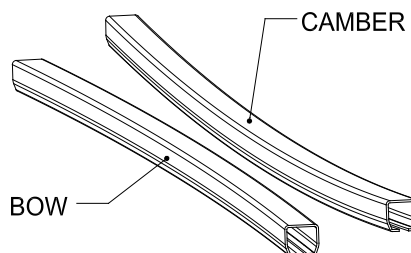
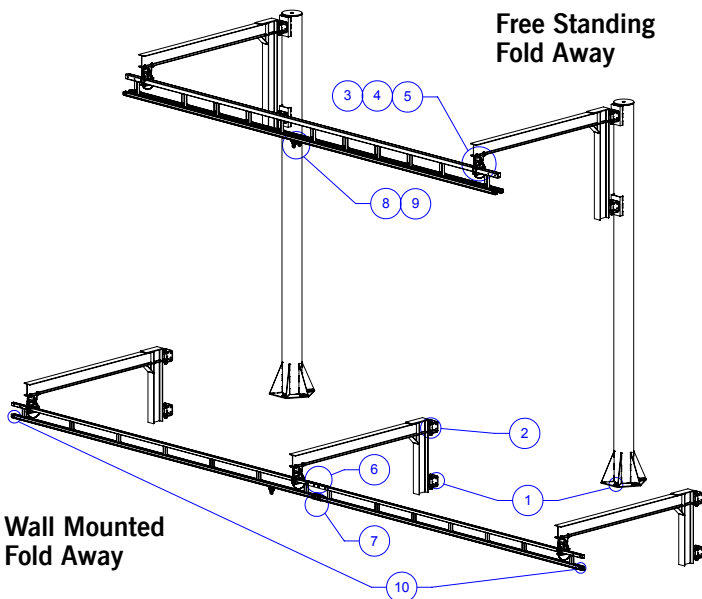

Diagram B. Camber and Bow.

Gorbel Tether Track® Fold Away Inspection and Maintenance Schedule			
Item	Component	Maintenance	Frequency*
1	Mounting Bolts	Check that lockwashers are compressed and nuts tightened to manufacturer's specifications.	Every 500 hours or 3 months
2	Pivot Assemblies	Check that lockwashers are compressed. Check for wear on thrust washers. Grease fittings (use Lubriplate #630-AA or equivalent).	Every 1000 hours or 6 months
3	Upper and Lower Hanger Bracket	Check that lockwashers are compressed and nuts are tightened to manufacturer's specifications.	Every 1000 hours or 6 months
4	Threaded Rod, Roll Pins & Spherical Nuts	Check that roll pins are intact. Check that spherical nuts are not galled with chair washers.	Every 1000 hours or 6 months
5	Wire Safety Sling and Chain Connector	Check for a good connection that wire sling is not frayed.	Every 1000 hours or 6 months
6	Truss Splice Plate	Check that lockwashers are compressed and nuts are tightened to manufacturer's specifications.	Every 1000 hours or 6 months
7	Splice Joint	All bolts should be in contact with track. Check track for alignment and that wheel rolling surface is flush.	Every 1000 hours or 6 months
8	Tether Trolley™ Connector	Check eyenut for wear. Check that clamp plate lockwashers are compressed. Check that black spring washer is not deformed and is in place. Confirm spring pin is in place. Check for smooth rolling action. Recover Trolley only: Check that guide bushing bolts are tightened to 10 ft-lbs and bushings spin freely.	Every 2000 hours or yearly
9	Wheels	Check for cracks, pits, and/or grooves: all of these increase pull forces. If any of these conditions exist, wheels should be replaced.	Every 2000 hours or yearly
10	End Stops	Check for full compression of lockwasher. If thru-bolt is exposed, replace endstops.	Every 2000 hours or yearly
11	Accessory Items	Conduct a general inspection of all accessory items.	Every 1000 hours or 6 months
12	Tether Track® Fold Away	Conduct a visual inspection of wall cantilever arm weldment, Tether Track® and mast weldment.	Every 1000 hours or 6 months
13	Capacity and Warning Labels	Check that all labels are in place and legible. Replace labels if damaged or illegible.	Every 2000 hours or yearly
14	Connecting Equipment	Inspect all protective equipment connected to the Tether Track® Anchorage System following the operation and maintenance manuals provided for each piece of equipment.	As required by manufacturer

***Federal, state and local codes may require inspection and maintenance checks more often. Please check the federal, state and local code manuals in your area. Gorbel recommends a certification inspection interval of no more than one year by a qualified person.**



! WARNING: Any changes in rolling effort or unusual noises must be immediately identified and corrected. It is not necessary to lubricate the track or bearings. Lubricating may attract airborne particles and may increase the rolling resistance. **Do not use such substances as WD40®, silicone sprays, oil or grease.**

Gorbel Inc.
600 Fishers Run, P.O. Box 593
Fishers, NY 14453-0593
Telephone: (800) 821-0086
(585) 924-6262
Fax: (800) 828-1808

! WARNING
This product contains chemicals known to the State of California to cause cancer and birth defects or other reproductive harm.
For more information: www.P65Warnings.ca.gov

©2026 Gorbel Inc.
All Rights Reserved