

Tether Track®

Ceiling Mounted Rigid Rail Anchor Systems

Installation, Operation & Maintenance Manual

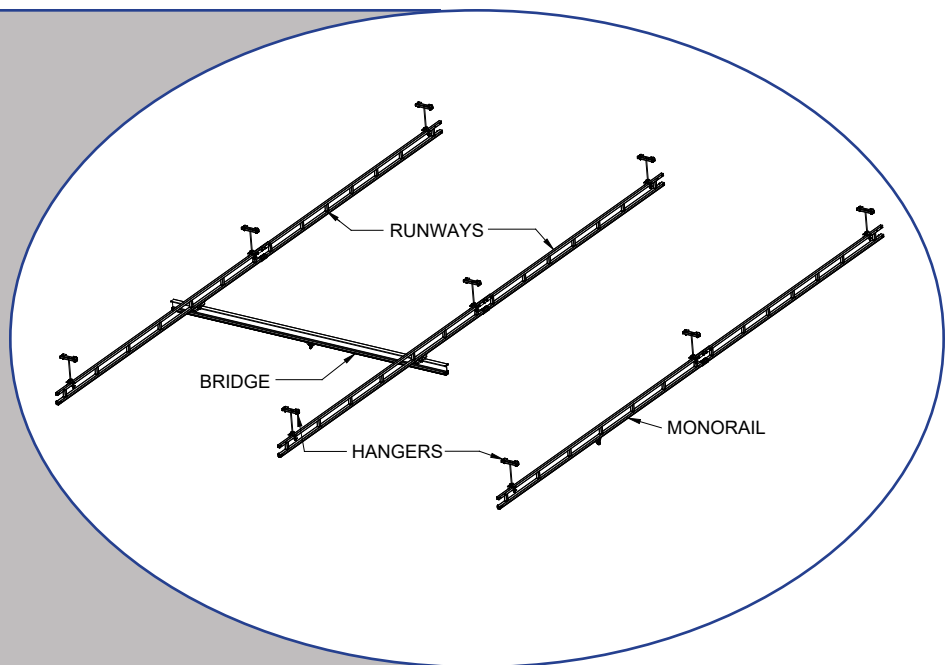

Part Number: MAN-US067-02 Released 1/2026
Find manual updates at:
<https://www.gorbel.com/service-support/archived-installation-manuals>



Scan to Register
Your Warranty

Gorbel Customer Order No. / Serial No.

Gorbel Dealer

TABLE OF CONTENTS

Introduction.....	1
Application.....	1
Definition of Terms.....	1
Warnings.....	2
Restrictions.....	2
Installation	
Step 1 - Pre-assembly.....	3
Step 2 - Hanger Installation.....	3-6
Step 3 - Runway or Monorail Installation.....	7-9
Step 4 - Splice Joint Installation.....	9-10
Step 5 - Bridge and End Truck Installation.....	11-12
Step 6 - Hoist Trolley Installation.....	12
Step 7 - Final Steps.....	12
Applied Forces to the Supporting Structure.....	13-14
Sway Bracing and Thrust Bracing Guidelines.....	15
Labels.....	16
Authorized Person Instructions.....	17
General Operational Suggestions.....	18
Limited Warranty.....	19
Inspection and Maintenance Schedule.....	20-22

Questions? Concerns? Comments? Please call (800) 821-0086 (US and Canada) or (585) 924-6262 (outside US).

INTRODUCTION

Thank you for choosing Gorbel® Tether Track® Ceiling Mounted Rigid Rail Anchor Systems to solve your fall protection needs. The innovative design and heavy-duty construction of the Gorbel® Tether Track® Anchor Systems will provide a superior quality product that will offer years of long term value. Gorbel® Tether Track® Anchor Systems have been optimally designed and tested to provide the ultimate solution for fall arrest systems. When properly applied, configured and installed under the supervision of a qualified person, Tether Track® Rigid Rail Anchor Systems will allow the ultimate in user mobility by providing a mobile rigid anchorage for the attachment of a lanyard or self-retracting lanyard (SRL). This reliable performance combined with an ANSI approved Managed Fall Protection Program gives the user the utmost safety assurance and encourages further safe work practices.

Tether Track® Rigid Rail Anchor Systems are designed using ANSI guidelines and comply with all OSHA requirements for a fall arrest anchorage system. Tether Track® Free Standing Rigid Rail Anchor Systems are designed to be statically proof tested up to 110% of the average arresting force (AAF). When loaded through proof testing or during a fall event, the Tether Track® Rigid Rail Anchor Systems will not incur any visual permanent deformation and may be placed back into service after performing the inspection requirements detailed in this manual. All engineered Tether Track® Rigid Rail Anchor Systems comply with OSHA's required safety factor of 2 and are designed in accordance with ANSI Z359.6. Gorbel® Tether Track® Anchor Systems will provide many years of dependable service by following the installation and maintenance procedures described herein.

APPLICATION

A Gorbel® Tether Track® Ceiling Mounted Monorail Anchor System is the best choice for providing coverage to a narrow rectangular fall zone when there is an available and adequate existing support structure. The rigid, self-tracking, overhead trolley anchorage, combined with the use of a Self Retracting Lanyard, provides the best solution to minimize fall distance when fall clearance height is restrictive.

Note: Specify SRL requirements at time of quote, standard design is for 900 pounds AAF.

A Gorbel® Tether Track® Bridge System offers the best solution to a wide rectangular fall zone. Combined with an SRL, this system allows for user mobility in 3 dimensions. A low inertia bridge (standard lengths to 15') slides effortlessly on runways, keeping both the anchorage trolley and bridge directly above the user. No other system eliminates swing falls as well as a Gorbel® Tether Track® Bridge Rigid Rail Anchorage System.

This product meets all applicable OSHA and ANSI standards for fall protection.

Dimensions contained in this installation manual are for reference only and may differ for your particular application. Please refer to the enclosed General Arrangement Drawing for actual dimensions.

Normal safety precautions: These include, but are not limited to:

- Checking for obstructions in the fall clearance zone
- Coordinating fall hazard activities with assigned rescue personnel
- Checking that all bolts and threaded rods are tight and have lockwashers
- Making sure that end stops are in place
- Making sure that trolley and bridge freely move

For additional safety precautions, see page 18.

DEFINITION OF TERMS

AUTHORIZED PERSON - ANSI defines an authorized person as a "person assigned by the employer to perform duties at a location where the person will be exposed to a fall hazard.

COMPLETE FALL ARREST SYSTEM - A complete fall arrest system consists of three main components:

- A) Engineered Anchor System - Gorbel's Tether Track® has been engineered to provide the maximum safety possible. This system allows for the greatest worker mobility through Gorbel's ergonomic enclosed track design. It provides minimal fall distance and obstruction impact by keeping the anchor point overhead and rigid.
- B) Body Support - Only a full body harness is allowed for fall arrest systems. Proper fitting and wearing of this harness is critical so that it can evenly dissipate the fall arrest forces to the strongest body parts.
- C) Connecting Means - This is the link between the anchor and body support. A self-retracting lifeline is recommended. This provides maximum mobility and minimum fall distance. An energy absorbing lanyard may also be used. Gorbel® recommends using components suited for overhead applications where activation distance (free fall) and average arrest force are as low as possible.

FALL CLEARANCE ZONE - The space below the person where there is a potential to fall. This space must remain clear of obstructions to prevent injury from contact with any objects during a fall event.

LEADING EDGE - The edge of the working surface that a person could fall off. This edge, if located parallel with the Tether Track® Monorail, may restrict the lifeline from reaching a vertical orientation and cause off-vertical (horizontal) loading of the anchorage system. Avoid sharp leading edges or use lifelines designed to withstand a sharp leading edge fall event.

QUALIFIED PERSON - ANSI defines a qualified person as "A person with a recognized degree or professional certificate and with extensive knowledge, training and experience in the fall protection and rescue field who is capable of designing, analyzing, evaluating and specifying fall protection and rescue systems..."

WARNINGS

1. Do not throw away these instructions.
2. Only competent erection personnel familiar with standard fabrication practices should be employed to assemble these anchor systems. Gorbel is not responsible for the quality of workmanship employed in the installation of an anchor system according to these instructions. Contact Gorbel Inc. at 600 Fishers Run, P.O. Box 593, Fishers, New York 14453-0593, 800-821-0086, for additional information if necessary.
3. Read and understand this manual before using equipment.
4. This manual should be read and understood in its entirety, and used as part of a training program as required by OSHA or any state and local regulatory agency.
5. This and any other included instructions must be provided to the users of this equipment. The user must understand the proper equipment use and limitations.
6. The Tether Track® Anchor System is only to be used as part of a complete fall protection system. The buyer or user is responsible for the safety and compatibility of the complete system.
7. Any component replacement, addition or change to the anchor system or the complete system requires evaluation by a qualified person.
8. Any fall event can result in injuries. The proper use of this equipment can substantially reduce an injury. For maximum safety, the worker must be trained in the proper use of this equipment and all of the components of the fall arrest system.
9. Before each use, the equipment shall be inspected as outlined in the inspection section of this manual.
10. The rated capacity, the rated average arresting force and the rated number of workers of the Tether Track® Anchor System must not be exceeded.
11. A managed fall protection program which includes a rescue plan is required for the safe use of this equipment. A worker suspended from this system can lose vital blood flow to the brain as blood pools in the legs. This is referred to as suspension trauma.
12. Reference the American Institute of Steel Construction (AISC) Manual of Steel Construction, Specification for Structural Joints using ASTM A325 or A490 Bolts (section 8.d.2) for the proper procedures to follow when using any torque tightening method.
13. Do not field modify the Tether Track® Ceiling Mounted Rigid Rail Anchor System in any way. Any modifications without the written consent of Gorbel Inc. will void warranty.
14. Gorbel has ensured the compatibility of Tether Track® **ONLY** with a Gorbel® approved connector (fall arrest trolley). It is the responsibility of the dealer or end user to ensure proper design, function and compatibility of any trolley used with Tether Track® that has not been validated by Gorbel for a fall arrest application.
15. Failure to follow these instructions can result in serious injury or death.

RESTRICTIONS

1. The Tether Track® Anchor System shall be used as part of a complete fall arrest system. Gorbel is not responsible for the installation of, or additional equipment added to the system. The Tether Track® Anchor System is manufactured by Gorbel in accordance with OSHA and ANSI Z359.1 and Z359.6 requirements using a minimum design factor of two. All components are designed in accordance with AISC and Aluminum Association guidelines.
2. The end user shall be responsible to make sure that the complete fall arrest system shall be designed, installed, and used under the supervision of a qualified person in accordance with applicable OSHA regulations and ANSI Z359 Fall Protection Code voluntary consensus standard in addition to any state and local jurisdiction.
3. It is the responsibility of the user to determine the suitability of this equipment and any attachments prior to each use. A certified inspection shall be performed by a qualified person at least once per year.
4. Customer chosen lanyards or SRLs shall minimize freefall distance.
5. It is the responsibility of the end user to verify that the mounting height of this Tether Track® Anchor System will provide adequate fall clearance when used with the customer chosen lanyard or SRL and harness.
6. Each trolley shall have no more than one person attached.
7. Bridges and trolleys are designed to freely move. To prevent a swing fall and lengthening of the free fall distance, the user shall verify the bridge and trolley maintains the closest possible distance to the user whenever he or she changes position.
8. The fall clearance zone shall be free of dangerous obstructions and electrical hazards.
9. The Tether Track® Anchor System is intended only for indoor use, unless noted on the General Arrangement drawing that it has been specifically designed for installation and use outdoors.
10. The Tether Track® Anchor System shall be installed per the general arrangement drawing without deviation or modification.
11. This system is not designed to be used as a crane. Gorbel accepts no responsibility for use of the Tether Track® Anchor System other than for its intended use.

INSTALLATION

STEP 1 - PRE-ASSEMBLY

➔ **TIP:** Packing list can be found in a plastic pocket attached to the hardware box: General Arrangement Drawing and additional inserts can be found enclosed in this installation manual.

WARNING

Confirm anchorage structure has been reviewed by a qualified person and meets the strength requirements for the application.

Inspect components as instructed in the inspection section.

Do not expose yourself to a fall hazard during installation without the appropriate protection.

- 1.1 Read entire installation manual **before** you begin installing your Tether Track® Anchor System.
- 1.2 Check packing list to make sure **correct quantity** of parts is included.
- 1.3 Tools and materials (by others) typically needed to assemble system are as follows:
 - Hand tools
 - Leveling tools
 - Ladders/man lifts
 - Powered metal-cutting saw
 - Steel shims (for flush mounted hangers)
 - Torque wrench (able to torque up to 100 ft. lb.)

STEP 2 - HANGER INSTALLATION

➔ **NOTE:** Standard top hanger brackets are designed for flange widths from 1"-3", 3-1/4"-5-1/4", 5-1/2"-7-1/2", 8"-10".

Top Hanger Assemblies

- 2.1 Mark top hanger placement on the building support beams and runway/monorail track (refer to the **General Arrangement Drawing**, inserted in this manual, for hanger placement). Installation parameters can be found on pages 13 and 14.

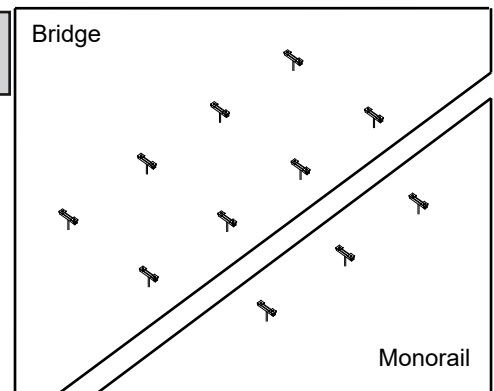

If you have standard hangers, go to Step 2.2, on page 4.

If you have sloped hangers, go to Step 2.3, on page 4.

WARNING

Ensure structural members are in good condition before attaching hangers.

Confirm that attachment points are adequately above the working surface to limit free fall to a maximum of 6'. Tether Trolley™ should be above D-ring on body harness.

STEP 2 - HANGER INSTALLATION (CONTINUED)

2.2 To attach threaded rod to top hanger bracket:

WARNING

Threaded rod must have a minimum of two threads beyond the hexnut.

Assemble top hanger assembly (**diagram 2A**). Refer to **chart 2A** for proper nut torque.

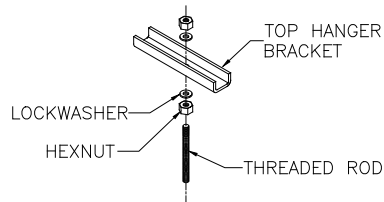

Diagram 2A. Attaching threaded rod to top hanger bracket.

TORQUE CHART

*Bolt Diameter	Torque
1/2"	50 ft.-lb.
5/8"	95 ft.-lb.

Chart 2A. Torque Chart.

*Note: All bolts shall be SAE Grade 5 or equal.

Go to Step 2.4, on page 5.

2.3 To attach clevis to top hanger bracket:

WARNING

Sloped ceiling hangers must not be installed on beams more than 15 degrees from horizontal.

Assemble top hanger assembly (**diagram 2B**). Refer to **chart 2A** for proper nut torque. Insert threaded rod into clevis (**diagram 2D**).

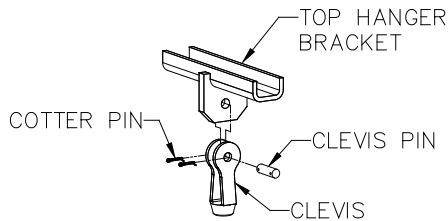

Diagram 2B. Attaching clevis to top hanger bracket.

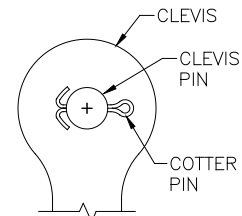

Diagram 2C. Installing cotter pin through clevis pin.

Bend both legs of all cotter pins (**diagram 2C**).

WARNING

Fully bend both legs of cotter pin (**diagram 2C**). If cotter pin is cracked or fatigued it must be replaced.

WARNING

Threaded rod must have a minimum of two threads beyond the clevis.

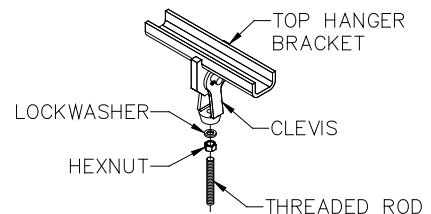

Diagram 2D. Attaching threaded rod to clevis.

STEP 2 - HANGER INSTALLATION (CONTINUED)

- 2.4 Bolt top hanger bracket assembly and beam clips to building support beam (*diagram 2E or 2F*). **Note:** Flange thickness may vary and require shimming. Shimming may be needed to assure that the beam clip hardware is vertical.

WARNING

“Center hole” of top hanger bracket assembly should be centered on building support beam but may be offset to prevent vertical interference.

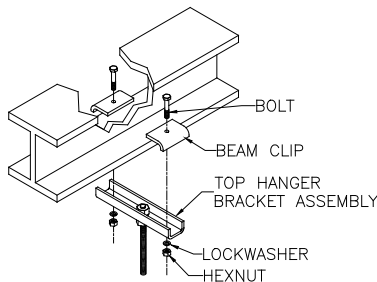

Diagram 2E. Bolting standard top hanger bracket and beam clips to existing support beam.

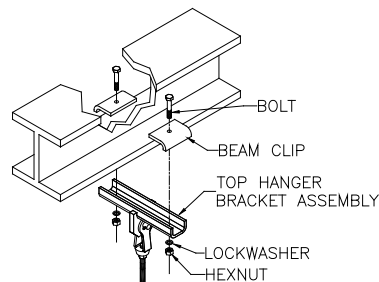

Diagram 2F. Bolting sloped top hanger bracket and beam clips to existing support beam.

Lower Hanger Assemblies

- 2.5 For untrussed (plain) track:

WARNING

Do not over-tighten clamping bolts on the lower hanger assemblies: this will cause permanent damage to the runway track.

Slide lower hanger assembly over the runway track and bolt into place with clamping bolts (*diagram 2G*).

Note: Install the vertical bolts for beam clips (Step 3.2, on page 7) on the Perpendicular Flush Mount Hanger (*diagram 2G*), before sliding it on the track.

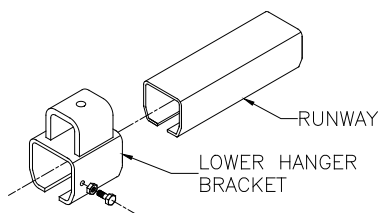

Plain Track

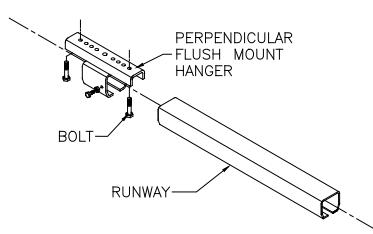

Perpendicular Flush Mount

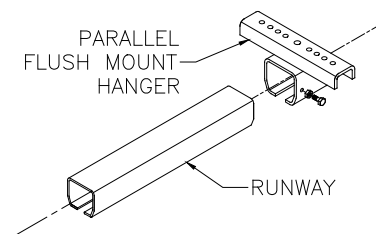

Parallel Flush Mount

Diagram 2G. Installing lower hanger assemblies on untrussed (plain) track.

For trussed track:

WARNING

Bolts must have a minimum of two threads beyond hexnut.

Bolt the lower hanger assembly and lower spine clamp plate to the top truss tube of runway (*diagram 2H*).

Tighten nuts until lockwashers are fully compressed.

Note: Sway brace brackets should be installed at this time (see page 15).

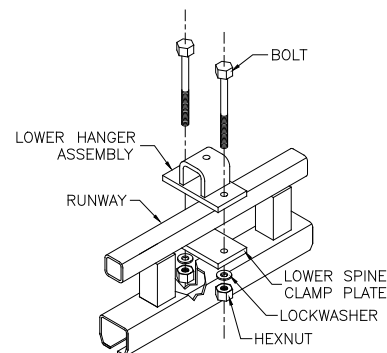

Trussed Track

Diagram 2H. Bolting lower hanger assembly and spine clamp plate to trussed track.

STEP 2 - HANGER INSTALLATION (CONTINUED)

Perpendicular Flush Mount

2.6 For trussed track:

WARNING

Threaded rod must have a minimum of two threads beyond hexnut.

Position spine clamp angles (or plates) so they are centered under top tube of runway at hanger locations. Bolt spine clamp angle (or plate) and top hanger brackets together leaving maximum amount of threaded rod available above top hanger bracket for installation of beam clips (**diagram 2I**).

WARNING

“Center hole” of top hanger brackets must be centered on building support beam.

Position runway top tube flush and perpendicular to building support beam. Bolt top hanger brackets and beam clips to support beam. Torque nuts (**chart 2A**, page 4, for proper torque rating).

Note: Flange thickness may vary and require shimming. Shimming may be needed to assure that the beam clip hardware is vertical. Refer to Step 3, on page 7, for further runway installation instructions.

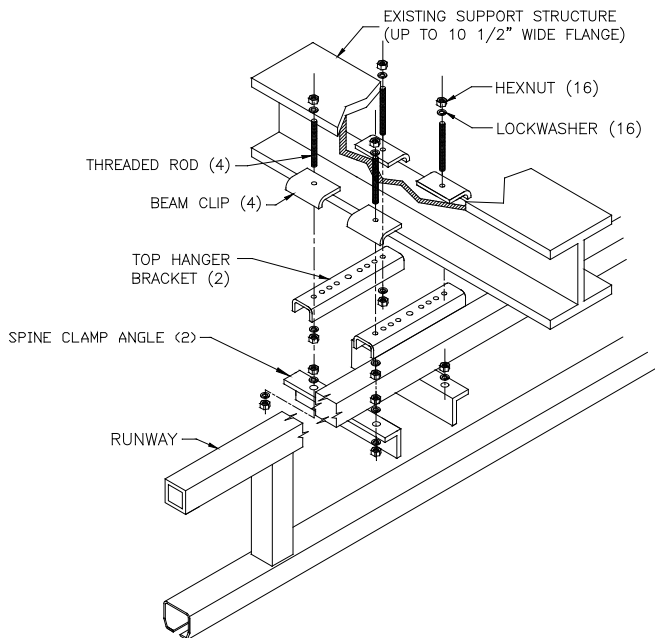

Trussed track with 1-1/2" to 2-1/2" top tube.

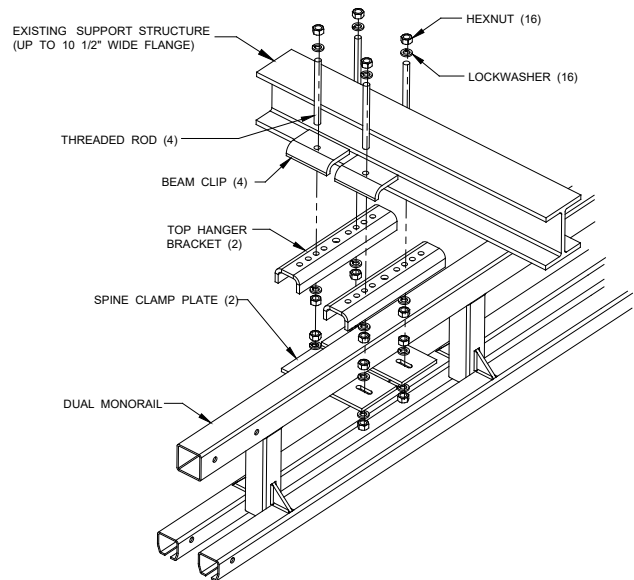

Dual Trussed track with 3" top tube.

Diagram 2I. Installing Perpendicular Flush Mounted Hangers on trussed track.

STEP 3 - RUNWAY OR MONORAIL INSTALLATION

- ➔ **NOTE:** The closer the runways/monorails are to level and parallel, the better the system will perform.
- ➔ **NOTE:** Track running-surface misalignment at joints shall be adjusted to within 1/32" (1mm) when installed.

3.1 Lift the runway/monorail into place for installation.

3.2 Hangers

WARNING

Threaded rod must have a minimum of two threads beyond the hexnut.

WARNING

Threaded rod must be allowed to hang "plumb" and should not be bent to accommodate sloped ceilings.

For standard and sloped ceiling hangers with threaded rod drop:
Insert threaded rod into bolt hole on the lower hanger assembly and bolt into place (*diagram 3A*).

Torque nuts (*chart 2A*, page 4, for proper torque rating).

For flush mounted standard hangers:

Bolt flush mounted hanger and beam clips to building support beam (*diagram 3B*).

Torque nuts (*chart 2A*, page 4, for proper torque rating).

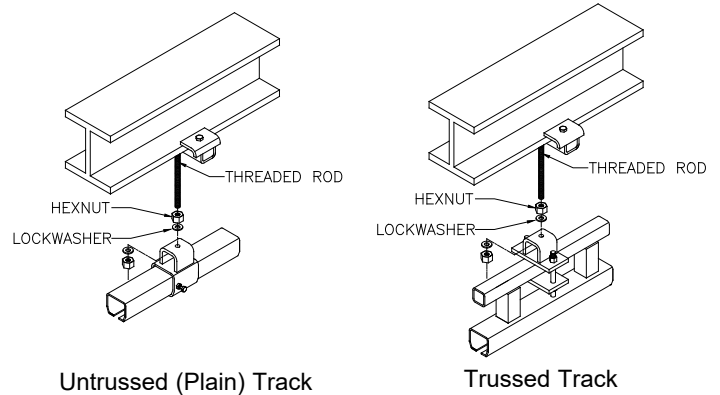
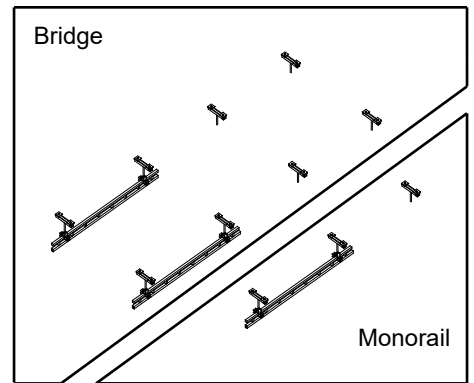

Diagram 3A. Attaching lower hanger assembly to top hanger assembly.

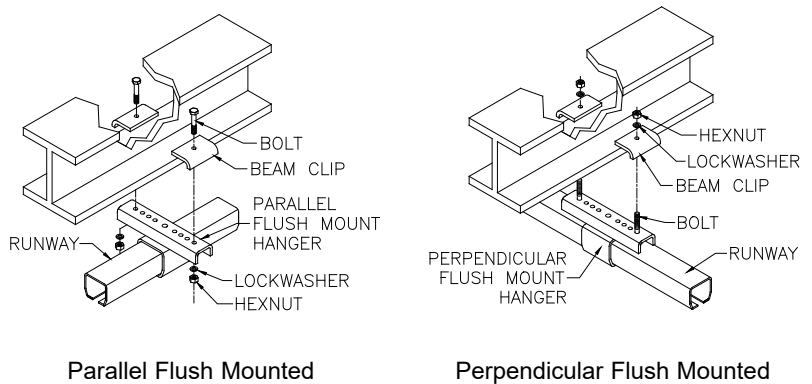

Diagram 3B. Attaching flush mounted hangers to building support beam.

STEP 3 - RUNWAY INSTALLATION (CONTINUED)

For flush mounted sloped ceiling hangers:

Insert bolt, with lockwasher, into bolt hole on the lower hanger assembly and fasten to clevis (*diagram 3C*).

Torque hardware (*chart 2A*, page 4, for proper torque rating).

WARNING

Bolt must have a minimum of two threads beyond the clevis.

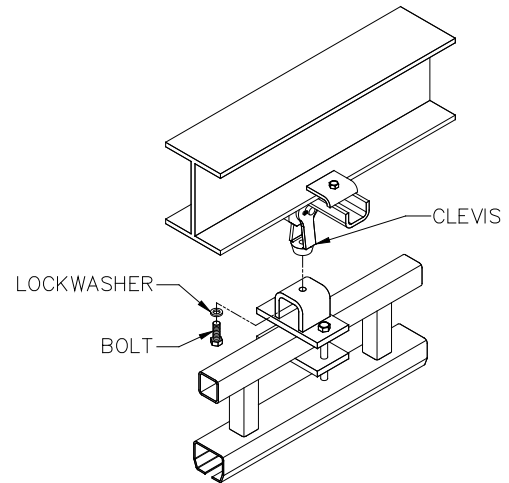

Diagram 3C. Attaching flush mounted sloped ceiling hangers to top hanger assembly.

For sloped ceiling hangers:

Beam clips must be welded to support beam to prevent clips from shifting (*diagram 3D*).

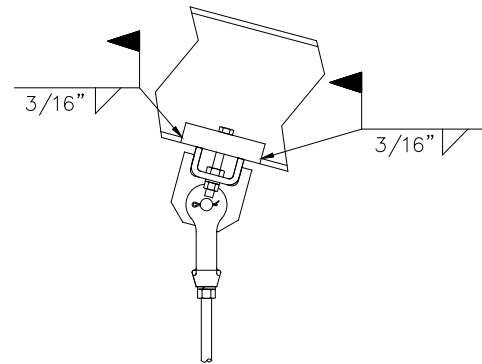

Diagram 3D. Welding beam clips to support beams.

For 3-hole hangers:

WARNING

Do not deviate from the dimensions specified in the General Arrangement Drawing for the maximum spacing of the runway hangers.

Insert threaded rod into bolt on the lower hanger assembly and through the pre-dilled holes in the runway top tube (*diagram 3E*).

Torque nuts (*chart 2A*, page 4, for proper torque rating).

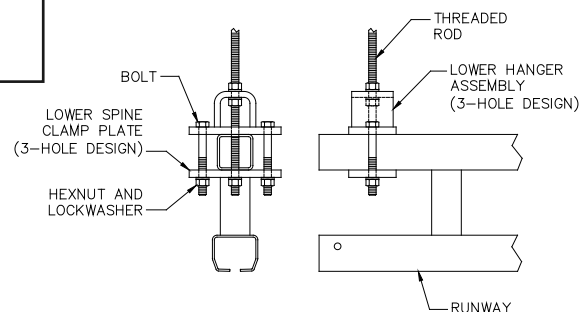

Diagram 3E. 3-Hole Hanger.

➡ **IMPORTANT:** Note the placement of the threaded rod hardware in *diagram 3E*. The lower hanger assembly and the truss top tube must be properly clamped to provide adequate support.

STEP 3 - RUNWAY INSTALLATION (CONTINUED)

3.3 Level track:

Check to make sure that the lower flange of track is level and parallel to opposite runway (within $\pm 1/32"$) at joints.

WARNING

Do not deviate from the bridge "span" dimension shown on the General Arrangement drawing. Bridge "span" is the distance between runways (centerline to centerline).

3.4 If you **do** have additional runways/monorail sections proceed to Step 4.

If you **do not** have additional runways/monorail sections:

Install end stops (*diagram 3F*) (molded bumper with thru bolt), in runway end.

Tighten nut on thru bolt until lockwasher is flat.

If you have a bridge system, go to Step 5, on page 11.

If you have a monorail, go to Step 6, on page 12.

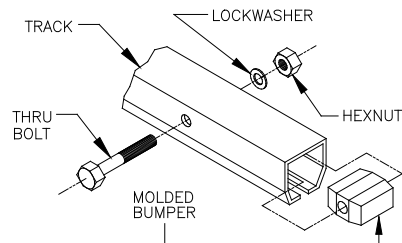

Diagram 3F. Installing end stop.

STEP 4 - SPLICE JOINT INSTALLATION

➔ **IMPORTANT:** If using trussed track, use both the splice joint and the splice plate.

➔ **IMPORTANT:** Suitable splices shall be provided at all track joints.

WARNING

Do not deviate from the dimensions specified in the General Arrangement Drawing for maximum space from hanger point to splice joint. Installation parameters can be found on pages 13-14.

4.1 Attach hardware to splice joint. Slide splice joint over track of installed runway/monorail.

4.2 The maximum gap between ends of the load carrying flange shall not exceed $1/16"$ (1.5mm).

4.3 Slide next runway/monorail section into splice joint, bringing runway/monorail ends as close as possible (*diagram 4A* or *4B*, on page 10).

Center the splice joint over the track ends.

4.4 For trussed track: Place a truss splice plate on each side of runway truss tube and bolt into place (*diagram 4B*, on page 10). Tighten hexnuts, but **do not torque** until you have completed Steps 4.4 and 4.5.

4.5 Refer to Step 2.5, on page 5, for lower hanger installation. Attach runway to upper hanger by repeating Steps 3.2, on page 7 and 3.4.

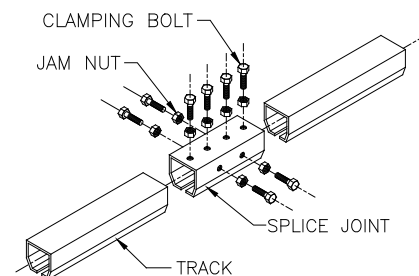
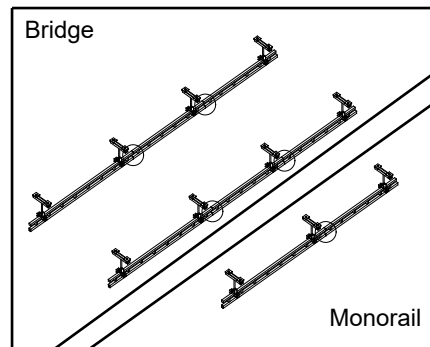

Diagram 4A. Splicing untrussed track.

STEP 4 - SPLICE JOINT INSTALLATION (CONTINUED)

4.6 Adjust track for smooth transition:

WARNING

Do not “over-tighten” clamping bolts on splice joints: this will cause permanent damage to the runway track. Clamping bolts are utilized for alignment purposes.

Tighten clamping bolts along the **top of splice joint** to force track down onto lower flanges of splice. Check to see that the transition from one track to the other is smooth: no raised areas to inhibit trolley or end truck operation.

Tighten clamping bolts along the **sides of splice joint** to align track laterally. Check to see that track portion of runway/monorail is horizontally and vertically flush.

Tighten jam nuts, on both the top and sides of the splice joint, to lock clamping bolts in place (*diagram 4A*, on page 9, or *4B*).

4.7 For trussed track: After you have adjusted the track for smooth transition, torque the truss splice plate hexnuts (*chart 2A*, on page 4).

For Z and ZD track:

4.8 Refer to the General Arrangement Drawing to plan the sequence in which the monorail sections will be installed. Monorail sections that have splice plate style connections (Z and ZD styles) may need to be assembled to the mating monorail section prior to lifting and installing on the headers. Do not lift greater than two assembled (splice plate style connection only) monorail sections at a time. Do not lift assemblies greater than 54 feet long. Do not allow more than 13 feet of track to extend past the header without support. For sleeve and truss plate style connections (S, SL, SLX and SLD styles), only lift these sections individually (not assembled).

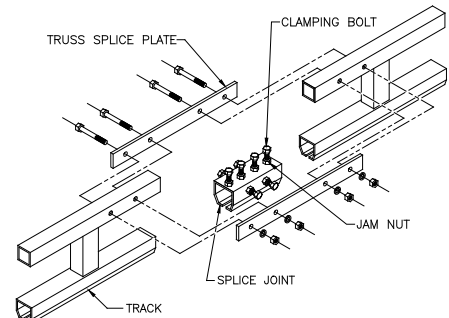

Diagram 4B. Splicing trussed track.

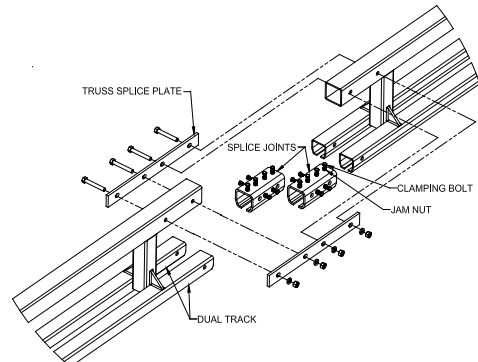

Diagram 4C. Splicing dual trussed track.

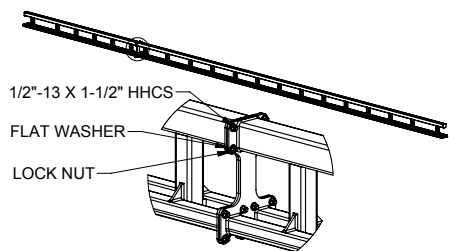

Diagram 4D. Plate style splice joint detail.

WARNING

The locations of the runways cannot deviate from the locations shown on the drawing. Changing the locations will void the design and the warranty.

4.9 Splice Joint Plate Style Connections: Align mating monorail sections and install hardware (*diagram 4D*). Verify track flanges (trolley wheel running surfaces) are aligned before tightening. Run a finger on the inside of the track flange and use a soft blow mallet to align plates until no lip is felt. Also check alignment of mating sections for bow and camber. Steel shims (by others) may be used between the splice plates to adjust any misalignment. Tighten hardware to 50 ft.-lbs. of torque per nut.

4.10 For additional runways repeat Steps 4.1 through 4.6, beginning on page 9.

4.11 Install end stops (Step 3.4, on page 9).

STEP 5 - BRIDGE AND END TRUCK INSTALLATION

➔ **IMPORTANT:** ONLY ONE end truck is clamped to the bridge: the other is not. The non-clamping end truck allows adjustment for any runway misalignment.

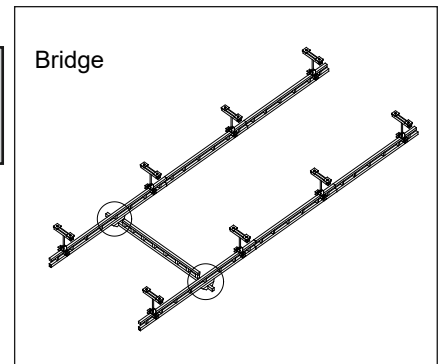

- 5.1 Make sure end stops have been installed in one end of the runway.
- 5.2 Prior to adding bridge, clean inside flanges of track with clean, dry cloth (**do not use any kind of cleaning solution**) to remove grit or debris that may have collected during shipping, storage, or installation.

➔ For Non-Coped Aluminum Bridges

- 5.3 Make sure nylon spacers are attached to end truck before installing end truck on bridge.
- 5.4 Slide an end truck over festooning end of bridge (refer to the **General Arrangement Drawing** for exact end truck location) and clamp into place (**diagram 5A**).
- 5.5 Slide and position the non-clamping end truck on the other end of bridge (refer to the **General Arrangement Drawing** for exact location).

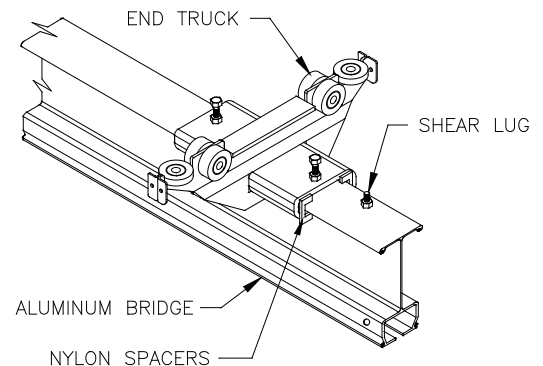

Diagram 5A. Installing clamping end truck on aluminum bridge. See **TIP**.

- 5.6 Go to Step 5.10.

➔ For Coped Aluminum Bridges

- 5.7 Make sure nylon spacers are attached to end truck before installing end truck on bridge.
- 5.8 Slide an end truck over coped brackets on the festooning end of bridge (refer to the **General Arrangement Drawing** for exact end truck location) and clamp into place (**diagram 5B**).
- 5.9 Slide and position the non-clamping end truck on the other end of bridge (refer to the **General Arrangement Drawing** for exact location).
- 5.10 At both ends of bridge, install a shear lug bolt in hole at top of bridge (or in the coped brackets) to prevent bridge from sliding out of end trucks (**diagrams 5A & 5B**).

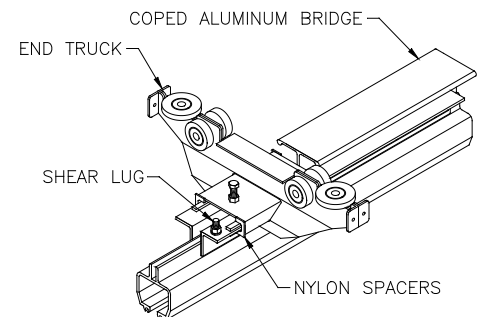

Diagram 5B. Installing clamping end truck on coped aluminum bridge. See **TIP**.

Note: Install bolts with head of bolt on underside of top flange with threads pointing up.

WARNING

Failure to install shear lug bolt assemblies may result in the bridge and worker falling to the floor.

STEP 5 - BRIDGE AND END TRUCK INSTALLATION (CONTINUED)

- 5.11 Install an end stop to the end of the bridge (*diagrams 5C or 5D*).
- 5.12 Lift bridge up to runways and simultaneously insert end trucks into open ends of runways.
- 5.13 **Immediately** install end stops in open ends of runways to prevent bridge from exiting runways (*diagrams 5C or 5D*).
- 5.14 Roll bridge down length of runways to check for smooth travel. If travel is not smooth, check track for level and parallel (Step 3.4, page 9) and check to make sure that only one end truck on bridge is clamped.

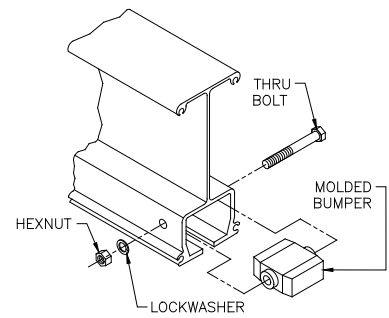

Diagram 5C. Installing end stop.

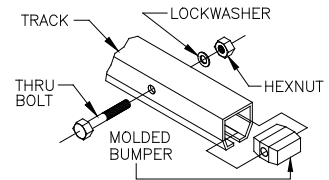

Diagram 5D. Installing end stop.

STEP 6 - HOIST TROLLEY INSTALLATION

- 6.1 Clean inside flanges of track with a clean, dry cloth (do not use any kind of cleaning solution) to remove grit or debris that may have collected during shipping, storage, or installation.
- 6.2 Be sure end stop is installed in one end of bridge/monorail.
- 6.3 Verify that the eyenut is securely fastened to the trolley with spring pin installed (refer to *diagram 6A*).
- 6.4 If using a self-retracting lifeline, attach self-retracting lifeline to trolley eye nut using ANSI approved hardware supplied with lifeline. Refer to the self-retracting lifeline manual.
- 6.5 Roll trolley into open end of track on bridge/monorail.
- 6.6 Install end stop on the open end of bridge/monorail (*diagram 5C or 5D*).

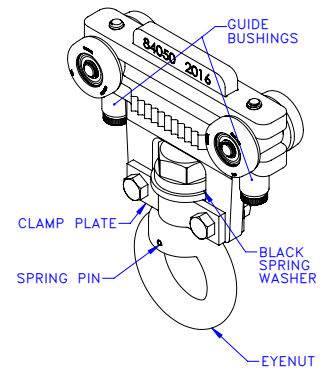

Diagram 6A. Tether Track® trolley installation.

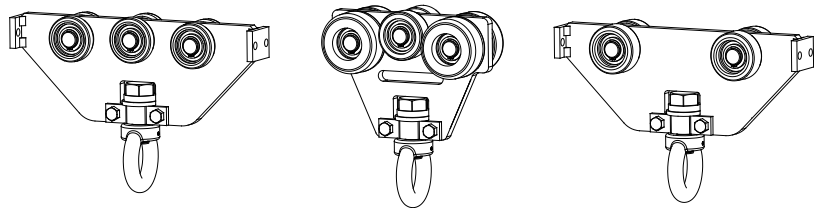

Diagram 6B. Various monorail and bridge trolley configurations.

STEP 7 - FINAL STEPS

➡ **TIP:** Do not throw away this manual: the maintenance schedule is on the back cover.

- 7.1 Check to make sure all bolts are tightened to specifications and lockwashers are flat.
- 7.2 Be sure to sway brace the system, except when using flush mounted hangers.
- 7.3 If necessary, touch up system with paint provided.
- 7.4 Install yellow rubber tracdoms on open ends of steel track.
- 7.5 Keep Packing List, Installation Manual, General Arrangement Drawing, and any other inserts filed together in a safe place.

INSTALLATION PARAMETERS AND APPLIED FORCES TO THE SUPPORTING STRUCTURE

The applied forces drawing in **Diagram 1**, details the relative position and the direction of forces that the Tether Track® Monorail Anchor System applies to the supporting structure.

Loads applied to the support structure can be determined by the following:

Variables

- P = 900 lb. Average Arresting Force
- R1 = Vertical arresting force and weight of system applied by end support hangers (lb.)
- R2 = Longitudinal arresting force from maximum offset arresting force angle of 30 degrees applied by end support lower hanger brackets thru trolley, end stop and track (lb.)
- R3 = Lateral arresting force from maximum offset arresting force angle of 30 degrees applied by end support lower hanger brackets thru trolley and track (lb.)
- R4 = Vertical arresting force and weight of system applied by middle support hangers (lb.)
- R5 = Lateral arresting force from maximum offset arresting force angle of 30 degrees applied by middle support lower hanger brackets thru trolley and track (lb.)
- L1 = Distance between hanger centerlines (support centers) (ft.)
- L2 = Maximum splice joint centerline to hanger centerline (support center) (in.)
- L3 = End approach loss from trolley and end stop (in.)
- L9 = Monorail cantilever (ft.)
- W = Weight per foot of Tether Track® (lb./ft)
- WT = Weight of trolley (lb.), 10# for F1000, 7# for all others
- LT = Length of trolley (in.), 12" for F1000, 11" for all others
- 1.5 = Recommended arresting force load factor

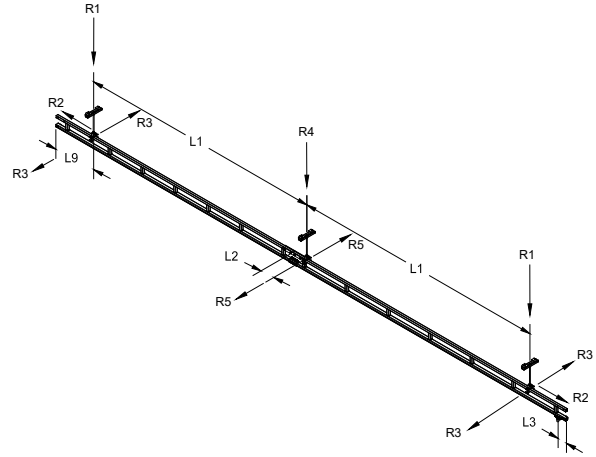

Diagram 1. Applied forces from monorail system to supporting structure.

INSTALLATION PARAMETERS MONORAILS							
TRACK STYLE	WEIGHT PER FT.	MAX. L1		MAX. L2	L3	MAX. L9	
		1 WORKER	2 WORKERS			1 WORKER	2 WORKERS
F500	4.23#	12'	7'	8"	8.5"	2.5'	1.5'
F1000	6.34#	18'	12'	8"	9"	4'	2.5'
F500S	7.78#	20'	16'	48"	8.5"	4.5'	3.5'
F500SL	11.14#	25'	18'	48"	8.5"	5.5'	4.5'
F500SLX	11.64#	30'	22'	48"	8.5"	5.5'	5.5'
F500SLD	17.17#	NA	35'	48"	8.5"	NA	5.5'
F500Z SPL PLT*	16.34#	50'	40'	48" .25*L1	8.5"	5.5'	5.5'
F500ZD SPL PLT**	22.92#	BA	50'	48" .25*L1	8.5"	NA	5.5'

* F500Z SPLICE PLATE DESIGN MUST BE USED ON TRACK CONNECTIONS LOCATED INSIDE SPANS GREATER THAN 30'
 ** F500ZD SPLICE PLATE DESIGN MUST BE USED ON TRACK CONNECTIONS LOCATED INSIDE SPANS GREATER THAN 35'

Formulas

For one worker:

$$R1 = (1.5 * P + WT) * (L1 + L9 - (L3 / 12)) / L1 + W * (L1 + L9)^2 / (2 * L1)$$

$$R2 \text{ \& } R5 = \sin(30^\circ) * 1.5 * P$$

$$R3 = \sin(30^\circ) * 1.5 * P * (L1 + L9 - (L3 / 12)) / L1$$

$$R4 = (1.5 * P + WT) + (W * L1)$$

For two workers:

$$R1 = (1.5 * P + WT) * (L1 + L9 - (L3 / 12)) / L1 + (1.5 * P + WT) * (L1 + L9 - (L3 / 12) - (LT / 12)) / L1 + W * (L1 + L9)^2 / (2 * L1)$$

$$R2 \text{ \& } R5 = 2 * \sin(30^\circ) * 1.5 * P$$

$$R3 = \sin(30^\circ) * 1.5 * P * (L1 + L9 - (L3 / 12)) / L1 + \sin(30^\circ) * 1.5 * P * (L1 + L9 - (L3 / 12) - (LT / 12)) / L1$$

$$R4 = 2 * (1.5 * P + WT) + (W * L1)$$

INSTALLATION PARAMETERS AND APPLIED FORCES TO THE SUPPORTING STRUCTURE (CONTINUED)

The applied forces drawing in **diagram 2**, details the relative position and the direction of forces that the Tether Track® Bridge Anchor System applies to the supporting structure.

Loads applied to the support structure can be determined by the following:

Variables

- P = 900 lb. Average Arresting Force
- R1 = Vertical arresting force and weight of system applied by end support hangers (lb.)
- R2 = Longitudinal arresting force from maximum offset arresting force angle of 30 degrees applied by end support lower hanger brackets thru trolley, bridge, end trucks, runway end stops and track (lb.)
- R3 = Lateral arresting force from maximum offset arresting force angle of 30 degrees applied by end support lower hanger brackets thru trolley, bridge end stop, bridge, end truck and track (lb.)
- R4 = Vertical arresting force and weight of system applied by middle support hangers (lb.)
- R5 = Lateral arresting force from maximum offset arresting force angle of 30 degrees applied by middle support lower hanger brackets thru trolley, bridge end stop, bridge, end truck and track (lb.)
- L1 = Distance between hanger centerlines (support centers) (ft.)
- L2 = Maximum splice joint centerline to hanger centerline (support center) (in.)
- L4 = Bridge span (distance between runway centerlines) (ft.)
- L5 = Bridge cantilever
- L8 = End approach loss from end truck and end stop (in.)
- L9 = Runway cantilever (ft.)
- W = Weight per foot of Tether Track® (lb./ft)
- WE = Weight of end truck (lb.), for F1000 runways: 27# for coped bridge, 19# for uncoped bridge, for all other runways: 18# for coped bridge, 10# for uncoped bridge
- LE = Length of end truck (in.), 23.9" for F1000 runway, 20.5" for all others
- 1.5 = Recommended arresting force load factor
- 8.5 = Bridge end approach loss from trolley and end stop (in.)
- 7 = Weight of trolley (lb.)
- 3.88 = Weight per foot of bridge (lb./ft.)

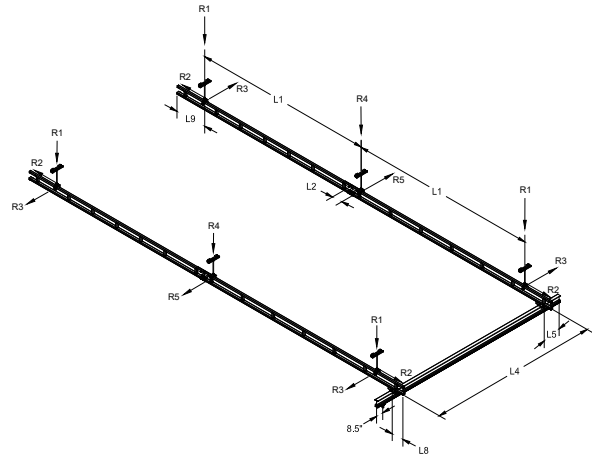

Diagram 2. Applied forces from bridge to supporting structure.

INSTALLATION PARAMETERS BRIDGES							
RUNWAY STYLE	WEIGHT PER FT.	MAX. L1		MAX. L2	L8	MAX. L9	
		1 BRIDGE	2 BRIDGES			1 BRIDGE	2 BRIDGES
F500	4.23#	12'	8'	8"	13.2"	2.5'	1.5'
F1000	6.34#	18'	12'	8"	15"	3.5'	2'
F500S	7.78#	20'	14'	48"	13.2"	4.5'	2'
F500SL	11.14#	25'	20'	48"	13.2"	5.5'	2.5'
F500SLX	11.64#	30'	25'	48"	13.2"	5.5'	2.5'
BRIDGE STYLE	WEIGHT PER FT.	MAX. L4 BRIDGE SPAN		MAX. L5			
AL250	3.88#	15'		3'			

Formulas

For one bridge:

$$R1 = ((1.5 * P + 7) * (L4 + L5 - (8.5 / 12)) / L4 + WE + 3.88 * (L4 / 2 + L5)) * (L1 + L9 - L8 / 12) / L1 + W * (L1 + L9)^2 / (2 * L1)$$

$$R2 = \sin(30^\circ) * 1.5 * P * (L4 + L5 - (8.5 / 12)) / L4$$

$$R3 = \sin(30^\circ) * 1.5 * P * (L1 + L9 - (L8 / 12)) / L1$$

$$R4 = (1.5 * P + 7) * (L4 + L5 - (8.5 / 12)) / L4 + WE + 3.88 * (L4 / 2 + L5) + W * L1$$

$$R5 = \sin(30^\circ) * 1.5 * P$$

For two bridges:

$$R1 = ((1.5 * P + 7) * (L4 + L5 - (8.5 / 12)) / L4 + WE + 3.88 * (L4 / 2 + L5)) * ((L1 + L9 - L8 / 12) + (L1 + L9 - L8 / 12 - LE / 12)) / L1 + W * (L1 + L9)^2 / (2 * L1)$$

$$R2 = 2 * \sin(30^\circ) * 1.5 * P * (L4 + L5 - 8.5 / 12) / L4$$

$$R3 = \sin(30^\circ) * 1.5 * P * ((L1 + L9 - L8 / 12) + (L1 + L9 - L8 / 12 - LE / 12)) / L1$$

$$R4 = 2 * ((1.5 * P + 7) * (L4 + L5 - (8.5 / 12)) / L4 + WE + 3.88 * (L4 / 2 + L5)) + W * L1$$

$$R5 = 2 * \sin(30^\circ) * 1.5 * P$$

SWAY AND THRUST BRACING GUIDELINES

➔ **TIP:** Sway bracing is not required on systems with flush mounted hangers.

WARNING

Bracing must be installed to resist damaging lateral and longitudinal loads.

Sway bracing must be located at or near each support location. It is required that each sway brace point shall not exceed the smaller of 10% of the spacing between supports or 24 inches from a support point. Maximum spacing shall not exceed 35 feet or as determined by structural analysis involving maximum unbraced length of the compression flange, and the horizontal length and horizontal deflection limit of the track.

Thrust bracing must be located at or near end hanger locations. It is required that each thrust brace point shall not exceed the smaller of the 10% of the spacing between supports or 24 inches from a support point. At a minimum, there should be two thrust braces per enclosed track runway.

Sway or thrust bracing must not be directly attached to hanger rods. All new bracing connecting to the flange of the track and flanges of building beams shall use sway brackets or equal as shown in **diagram 3**. When attaching bracing to steel truss or steel beams, the bracing member shall be attached to the top chord or top flange and located as close to the bridging members as possible.

Angle of bracing from vertical preferably should be equal to or greater than 45 degrees, but in no case be less than 30 degrees.

Generally, bracing is placed either parallel or perpendicular to track. However, skewed bracing is also permissible to accommodate difficult connections, such as the presence of ducts or pipes. Design of skewed bracing should use the same criteria for parallel/perpendicular bracing. For skewed thrust bracing, two pieces, symmetrical to the track, should be used if the skewed angle is greater than 10 degrees.

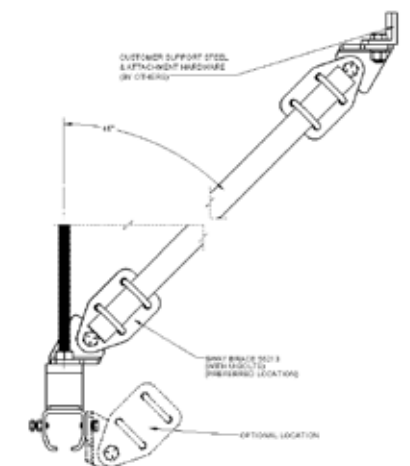
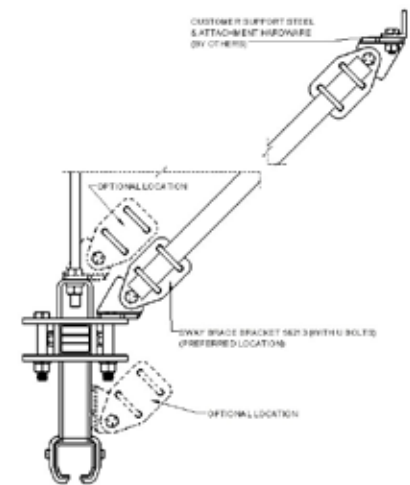
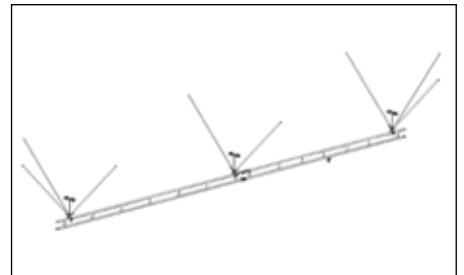
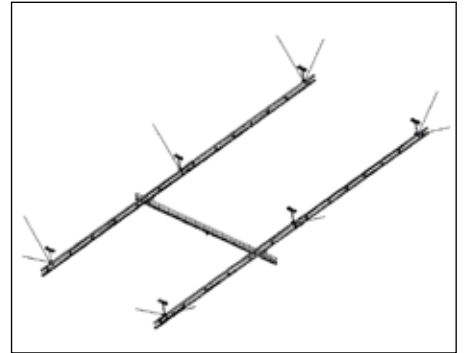

ANGLE AND PIPE BRACE TYPES Based on (KL/r = 300) Design Criteria

Size	Area (in ²)	r (in)	Max. Length (ft)	Allowable Force (kips)
1" Ø pipe SCH 40	0.49	0.421	10.5	0.81
1" Ø pipe SCH 80	0.64	0.407	10.17	1.06
L 2" x 2" x 1/4"	0.94	0.609	9.75	1.56
L 2 1/2" x 2 1/2" x 1/4"	1.19	0.769	12.28	1.98
L 3" x 3" x 1/4"	1.44	0.930	14.80	2.39

K = Effective Length Factor for a Prismatic Member (see AISC manual)
 L = Length of Brace
 r = Radius of Gyration

Diagram 3. Typical Connection detail.

LABELS

Bridge and Monorail Labels



TETHER TRACK™
FALL PROTECTION SYSTEMS
Fishers, NY, USA
COMPLIES WITH OSHA AND ANSI Z359.6 REQUIREMENTS

1 WORKER MAXIMUM
310 LBS CAPACITY
(140 KG) WORKER WITH TOOLS
1350 LBS (6 KN) MAXIMUM ARRESTING FORCE
900 LBS (4 KN) AVERAGE ARRESTING FORCE
GORBEL®
A CLASS ABOVE

One Worker, Bridge or Monorail Label



TETHER TRACK™
FALL PROTECTION SYSTEMS
Fishers, NY, USA
COMPLIES WITH OSHA AND ANSI Z359.6 REQUIREMENTS

2 WORKERS MAXIMUM
310 LBS CAPACITY
(140 KG) EACH WORKER WITH TOOLS
1350 LBS (6 KN) MAXIMUM ARRESTING FORCE PER WORKER
900 LBS (4 KN) AVERAGE ARRESTING FORCE PER WORKER
GORBEL®
A CLASS ABOVE

Two Workers, Monorail Label

WARNING

- INSPECT BEFORE EACH USE
- DO NOT EXCEED RATED CAPACITY AND RATED AAF
- ONLY TRAINED WORKERS SHOULD USE THIS PRODUCT
- ONLY COMPATIBLE COMPONENTS SHALL BE USED
- ONLY USE THIS PRODUCT AS PART OF A COMPLETE FALL ARREST SYSTEM UNDER THE SUPERVISION OF A QUALIFIED PERSON

FAILURE TO FOLLOW THESE INSTRUCTIONS AND THOSE IN THE INSTALLATION, OPERATION, & MAINTENANCE MANUAL SUPPLIED WITH THIS EQUIPMENT MAY RESULT IN SERIOUS INJURY OR DEATH.
P/N: 55-99110

Bridge and Monorail Warning Label

Trolley Labels

GORBEL
Fishers, NY, U.S.A.
Tether Trolleys™ CONNECTOR
STEEL/NYLON CONSTRUCTION
1 PERSON, 310 LBS CAPACITY
FOR MAXIMUM ARRESTING FORCE
- REFER TO MONORAIL OR BRIDGE
ANSI Z359.1(07) - LESS SURFACE FINISH TESTING
P/N: 55-99111 MADE IN THE USA

Trolley Label

WARNING

- INSPECT BEFORE EACH USE
- TROLLEY MUST REMAIN DIRECTLY OVERHEAD
- ONLY TRAINED WORKERS SHOULD USE THIS PRODUCT
- NO MORE THAN ONE WORKER SHALL BE ATTACHED
- ONLY COMPATIBLE COMPONENTS SHALL BE USED

FAILURE TO FOLLOW THESE INSTRUCTIONS AND THOSE IN THE INSTALLATION, OPERATION, & MAINTENANCE MANUAL SUPPLIED WITH THIS EQUIPMENT MAY RESULT IN SERIOUS INJURY OR DEATH.
P/N: 55-99112

Trolley Warning Label

WARNING

This product contains chemicals known to the State of California to cause cancer and birth defects or other reproductive harm.

For more information: www.P65Warnings.ca.gov

AUTHORIZED PERSON INSTRUCTIONS

Performing duties where a fall hazard exists can be dangerous. Therefore, it is important for the Authorized Person to be instructed in the use of their Complete Fall Arrest System and to understand the severe consequences of careless use. It is not intended that these suggestions take precedence over existing plant safety rules and regulations or OSHA regulations. However, a thorough study of the following information should provide a better understanding of safe use and afford a greater margin of safety. It must be recognized that these are suggestions for the authorized person working in the presence of a fall hazard. It is the responsibility of the owner to make personnel aware of all federal, state and local rules and codes, and to make certain authorized persons are properly trained.

Qualifications

Working while being exposed to a fall hazard, to be safe and efficient, requires skill: the exercise of extreme care and good judgment, alertness and concentration, and rigid adherence to proven safety rules and practices as outlined in applicable and current ANSI and OSHA safety standards. In general practice, no person should be authorized to work while being exposed to a fall hazard:

- Who cannot speak the appropriate language or read and understand the printed instructions.
- Who is not of legal age to work while being exposed to a fall hazard.
- Whose hearing or eyesight is impaired (unless suitably corrected with good depth perception).
- Who may be suffering from heart or other ailments which might interfere with their safe performance.
- Who may be pregnant or have any condition where the exposure to the average arresting force of a fall event may be a health risk.
- Unless the person has carefully read and studied this operation manual.
- Unless the person has been properly instructed.
- Unless there is a rescue plan in place and at least one additional authorized person that has been instructed in the implementation of the rescue plan.
- Unless the person has demonstrated his or her instructions through practical use of the Complete Fall Arrest System.
- Unless the person is familiar with fall protection equipment and the safe use of this equipment.

Handling the Bridge Travel Motion

Before using the bridge of the Tether Track® Anchorage System, the Authorized Person should be sure that the bridge is clear of any obstructions that would prevent it from freely traveling and that the fall zone, beneath where the work will be performed, is clear of any obstructions that would decrease the required fall clearance height. During use, the bridge should be brought into position so that it is directly over the Authorized Person. The bridge should follow the user's movement and remain overhead. Sudden movements should be avoided to prevent any inertia forces from the bridge causing a loss of balance. Only limited length aluminum bridges are used to keep inertia forces to a minimum. For multiple bridge systems, adequate clearance should be maintained to prevent bridges from impacting each other during a fall event.

Handling the Trolley Motion

Before using the trolley of the Tether Track® Anchorage System, the Authorized Person should be sure that the trolley is clear of any obstructions that would prevent it from freely travelling and that the fall zone, beneath where the work will be performed, is clear of any obstructions that would decrease the required fall clearance height. During use, the trolley should be brought into position so that it is directly over the Authorized Person. The trolley should follow the user's movement and remain overhead. Failure to keep the trolley overhead may cause a pendulum motion during a fall event that will increase fall distance and may expose the user to a side impact with any obstructions. A maximum off vertical angle of 30 degrees is allowed for monorail systems where the pendulum motion would be restricted by a leading edge. In this application, the leading edge may not be sharp enough to cause damage to the lanyard or self retracting lifeline web or cable; or an SRL specifically designed for a leading edge shall be used.

GENERAL OPERATIONAL SUGGESTIONS

Know Your Environment and Your Complete Fall Arrest System

Authorized persons should be familiar with the principal parts of the Fall Arrest System and have a thorough knowledge of the safe use, inspection, and limitations of this equipment. The authorized person should be required to know the procedure to rescue a person after a fall event and be trained to rapidly implement this procedure. The authorized person(s) should be aware of any conditions that may change while they are exposed to a fall hazard that may jeopardize the integrity of the fall arrest system and the rescue plan. For example, obstructions moving into a fall clearance zone.

Responsibility

Each authorized person(s) should be held directly responsible for the safe use of the Fall Arrest System. Whenever there is any doubt as to SAFETY, the authorized person should remove themselves from exposure to the fall hazard and refuse to re-expose themselves until safety has been assured. It is the responsibility of the employer to train the authorized person(s) in the safe use of the Fall Arrest System and to have a managed Fall Protection Plan in place.

Do not permit **ANYONE** to use this equipment unless they are authorized, there is at least one other authorized person within visual range, and there is a rescue plan in place.

Inspection

Test the Tether Track® Anchorage System movement and any attachments and connections before each use. Whenever the authorized person(s) finds anything wrong or apparently wrong, the problem should be reported immediately to the proper supervisor and appropriate corrective action taken.

Suggestions for use of the Tether Track® Anchorage System

The good authorized person should know and follow these suggestions for safe use of this protection equipment.

1. The bridge and/or trolley should move smoothly and gradually as the user moves. If a self retracting lifeline is being used and the retraction tension is not great enough to move the trolley and/or bridge, the user should abruptly jerk the lifeline to lock it and while maintaining tension in the lifeline, the user should pull on the lifeline until the trolley and/or bridge is overhead. Slack should then be removed by allowing the lifeline to retract. Slack should be kept to a minimum at all times. A maximum SRL weight of 40 lbs. applies to the Recover Trolley only.
2. The trolley should be located above the user and as close to the user as possible to minimize freefall distance. The user should verify that the trolley and/or bridge move as close as possible to the user whenever he or she moves. In the event of a fall, this will help to prevent swinging. The user must not work outside of the designed fall zone.
3. For bridge systems, lanyards and lifelines should be kept vertical. Monorail systems are designed to allow for a 30 degree off-vertical side pull. This maximum angle is selected to minimize the horizontal acceleration experienced during a swing fall. Offset falls, if not restricted by a vertical face, will increase the freefall distance. This extra distance must be accounted for in the fall clearance calculations.
4. Be sure everyone in the immediate area is aware of your use of fall protection equipment and that the fall zone remains clear. Confirm that there is at least one person visually aware of your activities and that there is an authorized fall rescue person on-site.
5. Do not exceed the rated load capacity, number of workers, or average arresting force of the Tether Track® Anchor System. Labels with this information are located on every track section for monorails and are located on the bridge for bridge systems.
6. Make certain that before exposing yourself to a fall hazard, components are properly connected, connectors are properly oriented and latches are fully closed and locked.
7. Check to be sure that all trip hazards are removed and that the fall protection zone is clear of dangerous obstructions when moving to a new location on the Tether Track® Anchor System. Be aware of the boundaries of the fall protection zone. This is detailed on your general arrangement drawing supplied with the manual at the time of shipment.
8. At no time should the authorized person be working alone while exposed to a fall hazard. In the event of a fall, a worker left suspended will lose the ability to circulate blood by the contractions of muscles in their legs. This combined with being suspended vertically will eventually result in lack of blood flow to the brain and can lead to death.
9. Do not use equipment with unused Y-lanyard webs, straps or tag lines hanging loose. These should be properly stored to prevent tripping hazards and the possibility of snagging during a fall event that may cause an excessive arresting force.
10. This equipment should not be used for any purpose other than fall protection unless it has been specifically designed for multiple purposes.
11. When multiple trolleys or bridges are provided on the same track(s), adequate spacing should be maintained between the trolleys or bridges to prevent any impact with each other during a fall event.
12. Whenever the authorized person leaves the Tether Track® Anchorage System the following procedure should be followed:
 - Verify that you are removed from the fall hazard or that you have another method of fall protection.
 - Remove your lifeline from the body harness D-ring or remove the lanyard from the trolley eye nut.
 - If using a self retracting lifeline, securely attach a tagline to the lifeline and allow it to slowly retract.
 - Remove lanyard and harness and clean any grease or dirt per manufacturers instructions. Allow to drip dry and store in a cool, clean, dry environment out of direct sunlight.
 - Make visual check before leaving anchor system.
 - Notify appropriate person that you are no longer using the fall arrest system.
13. After a fall event or if a safety concern is uncovered during inspection, an "out of service" warning sign or signal should be displayed at the access and egress point to this equipment until the system can be repaired or replaced and inspected.
14. ANY SAFETY FEATURES AND MECHANISMS BUILT-IN OR OTHERWISE PROVIDED WITH THE TETHER TRACK® ANCHOR SYSTEM BY GORBEL ARE REQUIRED FOR THE SAFE USE OF THIS EQUIPMENT. DO NOT, UNDER ANY CIRCUMSTANCES, REMOVE OR OTHERWISE IMPAIR OR DISABLE THE PROPER FUNCTIONING OF ANY SAFETY MECHANISMS OR FEATURES BUILT-IN OR OTHERWISE PROVIDED BY GORBEL FOR SAFE OPERATION OF THIS EQUIPMENT. ANY REMOVAL, IMPAIRMENT OR DISABLING OF ANY SUCH SAFETY MECHANISMS OR FEATURES OR OTHER OPERATION OF THE TETHER TRACK® ANCHOR SYSTEM WITHOUT THE COMPLETE AND PROPER FUNCTIONING OF ANY SUCH SAFETY MECHANISMS OR FEATURES AUTOMATICALLY AND IMMEDIATELY VOIDS ANY AND ALL EXPRESS AND IMPLIED WARRANTIES OF ANY KIND OR NATURE.

LIMITED WARRANTY

It is agreed that the equipment purchased hereunder is subject to the following LIMITED warranty and no other. Gorbel Incorporated ("Gorbel") warrants the manual push-pull Work Station Cranes, Jib Crane, Gantry Crane, and Tether Track® products to be free from defects in material or workmanship for a period of ten years or 20,000 hours use from date of shipment. Gorbel warrants the Motorized Work Station Cranes and Jib Crane products to be free from defects in material or workmanship for a period of two years or 4,000 hours use from the date of shipment. Gorbel warrants the G-Force® and Easy Arm® products to be free from defects in material or workmanship for a period of one year or 2,000 hours use from the date of shipment. This warranty does not cover Gantry Crane wheels. This warranty shall not cover failure or defective operation caused by operation in excess of recommended capacities, misuses, negligence or accident, and alteration or repair not authorized by Gorbel. No system shall be field modified after manufacture without the written authorization of Gorbel, Inc. Any field modification made to the system without the written authorization of Gorbel, Inc. shall void Gorbel's warranty obligation. OTHER THAN AS SET FORTH HEREIN, NO OTHER EXPRESS WARRANTIES, AND NO IMPLIED WARRANTIES, ORAL OR WRITTEN, INCLUDING BUT NOT LIMITED TO THE WARRANTIES OF MERCHANTABILITY OR FITNESS FOR A PARTICULAR PURPOSE, ARE MADE BY GORBEL WITH RESPECT TO ITS PRODUCTS AND ALL SUCH WARRANTIES ARE HEREBY SPECIFICALLY DISCLAIMED. GORBEL SHALL NOT BE LIABLE UNDER ANY CIRCUMSTANCES FOR ANY INCIDENTAL, SPECIAL AND/OR CONSEQUENTIAL DAMAGES WHATSOEVER, WHETHER OR NOT FORESEEABLE, INCLUDING BUT NOT LIMITED TO DAMAGES FOR LOST PROFITS AND ALL SUCH INCIDENTAL, SPECIAL AND/OR CONSEQUENTIAL DAMAGES ARE HEREBY ALSO SPECIFICALLY DISCLAIMED. Gorbel's obligation and Purchaser's or end user's sole remedy under this warranty is limited to the replacement or repair of Gorbel's products at the factory, or at the discretion of Gorbel, at a location designated by Gorbel. Purchaser or end user shall be solely responsible for all freight and transportation costs incurred in connection with any warranty work provided by Gorbel hereunder. Gorbel will not be liable for any loss, injury or damage to persons or property, nor for damages of any kind resulting from failure or defective operation of any materials or equipment furnished hereunder. Components and accessories not manufactured by Gorbel are not included in this warranty. Purchaser's or end user's remedy for components and accessories not manufactured by Gorbel is limited to and determined by the terms and conditions of the warranty provided by the respective manufacturers of such components and accessories.

A) DISCLAIMER OF IMPLIED WARRANTY OF MERCHANTABILITY

Gorbel and Purchaser agree that the implied warranty of merchantability is excluded from this transaction and shall not apply to the goods involved in this transaction.

B) DISCLAIMER OF IMPLIED WARRANTY OF FITNESS FOR PARTICULAR PURPOSE

Gorbel and Purchaser agree that the implied warranty of fitness for particular purpose is excluded from this transaction and shall not apply to the goods involved in this transaction.

C) DISCLAIMER OF EXPRESS WARRANTY

Gorbel's agents, or dealer's agents, or distributor's agents may have made oral statements about the machinery and equipment described in this transaction. Such statements do not constitute warranties, and Purchaser agrees not to rely on such statements. Purchaser also agrees that such statements are not part of this transaction.

D) DISCLAIMER OF SPECIAL, INCIDENTAL AND CONSEQUENTIAL DAMAGES

Gorbel and Purchaser agree that any claim made by Purchaser which is inconsistent with Gorbel's obligations and the warranty remedies provided with Gorbel's products, and in particular, special, incidental and consequential damages, are expressly excluded.

E) DEALER OR DISTRIBUTOR NOT AN AGENT

Gorbel and Purchaser agree that Purchaser has been put on notice that dealer or distributor is not Gorbel's agent in any respect for any reason. Gorbel and Purchaser also agree that Purchaser has been put on notice that dealer or distributor is not authorized to incur any obligations or to make any representations or warranties on Gorbel's behalf other than those specifically set forth in Gorbel's warranty provided in connection with its product.

F) MERGER

This warranty agreement constitutes a final and complete written expression of all the terms and conditions of this warranty and is a complete and exclusive statement of those terms.

G) PAINTING

Every crane (excluding components) receives a quality paint job before leaving the factory. Unfortunately, no paint will protect against the abuses received during the transportation process via common carrier. We have included at least one (1) twelve ounce spray can for touchup with each crane ordered (unless special paint was specified). If additional paint is required, contact a Gorbel® Customer Service Representative at 1-800-821-0086 or 1-585-924-6262.

Title and Ownership:

Title to the machinery and equipment described in the foregoing proposal shall remain with Gorbel and shall not pass to the Purchaser until the full amount herein agreed to be paid has been fully paid in cash.

Claims and Damages:

Unless expressly stated in writing, goods and equipment shall be at Purchaser's risk on and after Seller's delivery in good shipping order to the Carrier. Gorbel shall in no event be held responsible for materials furnished or work performed by any person other than it or its authorized representative or agent.

Cancellations:

If it becomes necessary for the purchaser to cancel this order wholly or in part, he shall at once so advise Gorbel in writing. Upon receipt of such written notice all work will stop immediately. If the order entails only stock items, a flat restocking charge of 15% of the purchase price will become due and payable by Purchaser to Gorbel. Items purchased specifically for the canceled order shall be charged for in accordance with the cancellation charges of our supplier plus 15% for handling in our factory. The cost of material and/or labor expended in general fabrication for the order shall be charged for on the basis of total costs to Gorbel up to the time of cancellation plus 15%.

Returns:

No equipment, materials or parts may be returned to Gorbel without express permission in writing to do so.

Extra Charge Delay: If Purchaser delays or interrupts progress of Seller's performance, or causes changes to be made, Purchaser agrees to reimburse Gorbel for expense, if any, incident to such delay.

Changes and Alterations:

Gorbel reserves the right to make changes in the details of construction of the equipment, as in its judgment, will be in the interest of the Purchaser; will make any changes in or additions to the equipment which may be agreed upon in writing by the Purchaser; and Gorbel is not obligated to make such changes in products previously sold any customer.

Third Party Action:

Should Gorbel have to resort to third party action to collect any amount due after thirty (30) days from date of invoice, the Purchaser agrees to pay collection costs, reasonable attorney's fees, court costs and legal interest.

OSHA Responsibilities:

Gorbel agrees to fully cooperate with Purchaser in the design, manufacture or procurement of safety features or devices that comply with OSHA regulations. In the event additional equipment or labor shall be furnished by Gorbel, it will be at prices and standard rates then in effect, or as may be mutually agreed upon at the time of the additional installation.

Equal Employment Opportunity:

Gorbel agrees to take affirmative action to ensure equal employment opportunity for all job applicants and employees without regard to race, color, age, religion, sex, national origin, handicap, veteran, or marital status. Gorbel agrees to maintain non-segregated work facilities and comply with rules and regulations of the Secretary of Labor or as otherwise provided by law or Executive Order.

INSPECTION AND MAINTENANCE SCHEDULE

GORBEL® TETHER TRACK® BRIDGE AND MONORAIL ANCHOR SYSTEMS: INSPECTION BEFORE EACH USE

OSHA and ANSI require an inspection of the entire fall protection system before each use. The Tether Track® Anchor System is a vital component of the complete fall protection system. Checking for the proper functioning of this system is essential. These pre-use checks are intended to be tactile and visual.

If the required maintenance procedures have been properly followed, connections between the track and supporting structure will remain secure. Any extreme conditions that you are aware of that may have occurred since the last maintenance procedure should be reported to the proper supervisor and an evaluation made to determine if the maintenance schedule requires modification. Some examples of extreme conditions are: a fall arrest event, excessive vibration in the system or structure, swaying of the support structure, an impact to the system or support structure, or an unauthorized person working on the system.

The previous sections, Authorized Person Instructions and General Operational Suggestions, provide important pre-use and in-use instructions and inspection guidance. The following provides a suggested checklist divided into the six main components of the Tether Track® Anchor System. Components not listed require pre-use inspection as detailed by their manufacturers.

	YES	NO!
AUTHORIZED PERSON		
Are you authorized by your employer to perform work at height?		
Are you aware of a written procedure for the use of this equipment and does it include a rescue plan?		
Have you been trained in the use of this equipment?		
SURROUNDING ENVIRONMENT		
Is this system being used as approved by a qualified person?		
Is there adequate clearance to arrest a fall?		
Will you remain in the fall zone area allowed by this system?		
Are dangerous obstructions removed from the fall zone?		
Are nearby people aware of your pending work at height?		
Is there an authorized person within sight that has been trained in the rescue procedure?		
SUPPORTING STRUCTURE		
Is the integrity of the structure adequate?		
CONNECTIONS TO TETHER TRACK®		
Has scheduled maintenance been appropriately performed?		
TETHER TRACK®		
Is track rigid and horizontal?		
Is track free of deformed, bent or damaged sections?		
Are endstops in place?		
Is the Tether Track® Anchor System rated for the capacity and number of people using it?		
TROLLEY		
Is there only one lanyard or SRL attached to the trolley?		
Is lanyard or SRL compatibly attached to trolley eyenut?		
Does trolley freely roll and remain overhead?		

If the answer to any of these questions on the checklist is no, remove yourself from the fall hazard and report the issue to the proper supervisor.

INSPECTION AND MAINTENANCE SCHEDULE

GORBEL® TETHER TRACK® BRIDGE AND MONORAIL ANCHOR SYSTEMS: INSPECTION AFTER A FALL ARREST EVENT

Runway/Monorail/Bridge

- Support each Tether Track® section by other means and loosen all support hardware (splice joint, top hanger, lower hanger bracket, truss splice plate, clamped endtruck and sway braces). This will relieve any stress and misalignment in the anchor system members that may be retained by the hardware from the arresting force. Any misalignment caused by hardware/member shift must be removed before the track sections can be measured for permanent deformation.
- Ensure all fitments and track sections are aligned. Re-tighten hardware on all components per installation instructions in this manual.
- At the location in the track where the fall arrest incident took place, measure the track opening and compare to the dimension and tolerance shown in **Diagram A**. Replace section of track if measurement is not within the tolerance.
- Verify the Tether Track® members have not undergone any other permanent deformation. This can be achieved by measuring the chamber and bow (**Diagram B**) of the enclosed track member and top tube member (if trussed track).
 - Using a string (kite), two clamps, and a measuring device (ruler, tape measure, etc.), measure from support to support (covering track area where arrest took place).
 - Clamp one end of string to the concave face of track, at the support. Travel to the other support pulling the string taut, not allowing it to sag, and clamp it in same location on track at the support.
 - Measure the distance from the string to the track face where this distance is greatest (usually at mid-span).
 - If this measurement is greater than $.125'' \times \text{Length of track in feet between supports} / 10'$ then replacement of track section is required.
 - Repeat this for both bow and chamber of both the enclosed track member and top tube member (if trussed).
 - If arrest took place on cantilevered portion of track, measurement will be from end of track to first support.
- Visually inspect endstops for fractures or deformation, replace if any are found.

Trolley

- Roll trolley in track listening for abnormal thumping noise. If heard, this indicates there maybe debris sticking to wheel(s) or a flat spot on wheel(s) and wheel replacement is required.
- Remove endstop and carefully remove trolley from track section, install endstop bolt back into hole for safety purposes.
- Inspect trolley wheels for debris, clean off if any debris is found with clean dry cloth.
- Inspect black polyurethane washer between bolt head and metal washer for deformity. If bolt head is wedged into washer, press up on eyebolt while pulling down with hands until black washer and bolt head have separated.
- Further, visually inspect trolley wheels for flat spots and/or fractures. If any are found, specific wheel replacement is necessary.
- Place trolley back into track and secure with endstop and hardware.

WARNING

All other components are to be inspected per their manufacturer's instructions.

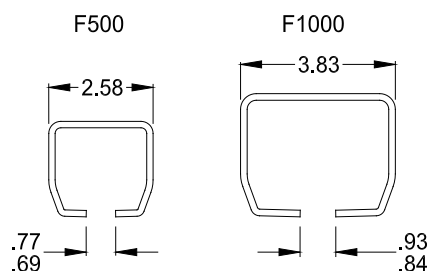

Diagram A. Track Opening Specification.

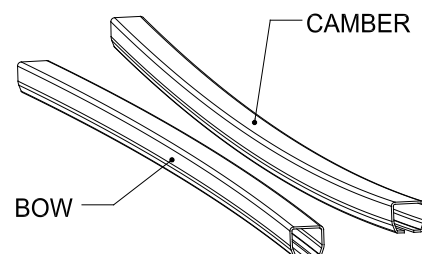

Diagram B. Camber and Bow.

INSPECTION AND MAINTENANCE SCHEDULE

GORBEL® TETHER TRACK® BRIDGE AND MONORAIL ANCHOR SYSTEMS: INSPECTION AND MAINTENANCE SCHEDULE			
ITEM	COMPONENT	MAINTENANCE	FREQUENCY*
1	Top Hanger Bracket/Beam Clips/Threaded Rod	Check that lockwashers are compressed and nuts are tightened to manufacturer's specifications.	Every 2,000 hours or yearly.
2	Lower Hanger Bracket	Check that lockwashers are compressed and nuts are tightened to manufacturer's specifications.	Every 2,000 hours or yearly.
3	Truss Splice Plate	Check that lockwashers are compressed and nuts are tightened to manufacturer's specifications.	Every 2,000 hours or yearly.
4	Splice Joint	All bolts should be in contact with track. Check track for alignment and that wheel rolling surface is flush.	Every 2,000 hours or yearly.
5	Tether Trolley™ Connector	Check eyenut for wear. Check that clamp plate lockwashers are compressed. Check that black spring washer is not deformed and is in place. Confirm spring pin is in place. Check for smooth rolling action. Recover Trolley only: Check that guide bushing bolts are tightened to 10 ft-lbs and bushings spin freely.	Every 2,000 hours or yearly.
6	End Stops (runway/bridge/monorail)	Check for full compression of lockwasher. If thru-bolt is exposed, replace endstops.	Every 2,000 hours or yearly.
7	Wheels	Check for cracks, pits, and/or grooves: all of these increase pull forces. If any of these conditions exist, wheels should be replaced.	Every 2,000 hours or yearly.
8	Aluminum Bridge Assembly Hardware	Check that lockwashers are compressed and nuts are tightened to torque specifications (chart 2A, page 2).	Every 2,000 hours or yearly.
9	Capacity and Warning Labels	Check that all labels are in place and legible. Replace labels if damaged or illegible.	Every 2,000 hours or yearly.
10	Connecting Equipment	Inspect all protective equipment connected to the Tether Track® Anchorage System following the operation and maintenance manuals provided for each piece of equipment.	As required by manufacturer.

*Federal, state and local codes may require inspection and maintenance checks more often. Please check the federal, state and local code manuals in your area. Gorbel recommends a certification inspection interval of no more than one year by a qualified person.

WARNING

Any changes in rolling effort or unusual noises must be immediately identified and corrected. It is not necessary to lubricate the track or bearings. Lubricating may attract airborne particles and may increase the rolling resistance. (Do not use such substances as WD-40®, silicone sprays, oil or grease on bearings or on track flanges.)

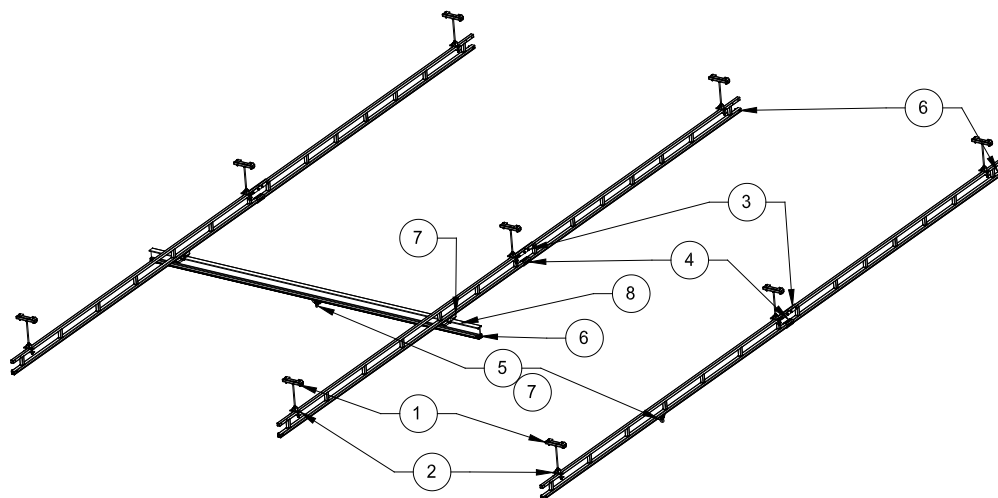

GORBEL®
A CLASS ABOVE

600 Fishers Run, P.O. Box 593
Fishers, NY 14453-0593
Phone: (800) 821-0086
Fax: (800) 828-1808
E-Mail: info@gorbel.com
<http://www.gorbel.com>

© 2026 Gorbel, Inc.
All Rights Reserved



[linkedin.com/company/gorbel](https://www.linkedin.com/company/gorbel)



[Facebook.com/gorbelinc](https://www.facebook.com/gorbelinc)



[youtube.com/gorbelmarketing](https://www.youtube.com/gorbelmarketing)



[instagram.com/gorbelinc](https://www.instagram.com/gorbelinc)



[gorbel.com/blog](https://www.gorbel.com/blog)