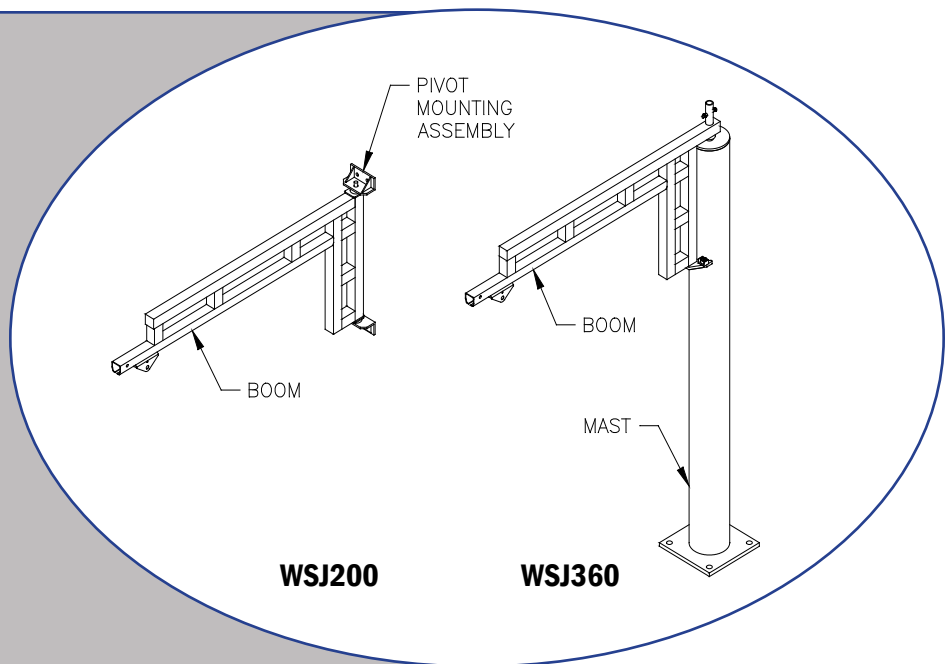


# Work Station Jib Crane

## Installation, Operation & Maintenance Manual



Part Number: MAN-US061-R02 Released 3/2026  
Find manual updates at:  
<https://www.gorbel.com/service-support/archived-installation-manuals>



Scan to Register  
Your Warranty

Gorbel® Customer Order No. / Serial No.

Gorbel® Dealer

Continued on next page.

# TABLE OF CONTENTS

Introduction.....	1
Installation	
Step 1 - Pre-assembly .....	2-3
Step 2 - WSJ200 (Wall/Column Mounted) Boom Installation.....	4
Step 3 - WSJ360 (Free Standing) Mast Installation .....	5-10
Step 4 - WSJ360 (Free Standing) Boom Installation .....	11
Step 5 - Hoist Trolley Installation.....	12
Step 6 - Festooning Installation .....	13
Step 7 - Tagline Installation .....	14
Step 8 - Friction Brake Installation .....	14-15
Step 9 - Accessories.....	16-17
Step 10 - Final Steps.....	17
Crane Operator Instructions .....	18
General Safety Requirements .....	18
Limited Warranty .....	19
Inspection and Maintenance Schedule .....	20

Questions? Concerns? Comments? Please call (800) 821-0086 (US and Canada) or (585) 924-6262 (outside US).

Continued on next page.

# INTRODUCTION

Thank you for choosing Gorbel® Work Station Jib Cranes to solve your material handling needs. The innovative design and heavy duty construction of Gorbel® Work Station Jib Cranes will provide a superior quality product that will offer years of long term value. All Gorbel® cranes are pre-engineered for powered hoist operation. The hoist weight allowance is 15% of the crane capacity (for example, a crane rated for 1000 pounds allows for a 1000-pound live load plus 150 pounds for the weight of the hoist). There is also an allowance of 25% of the crane capacity for impact caused by hoist use. Gorbel® Work Station Jib Cranes will provide many years of dependable service by following the installation and maintenance procedures described herein.

***Dimensions contained in this installation manual are for reference only and may differ for your particular application. Please refer to the enclosed General Arrangement Drawing for actual dimensions.***

**Normal safety precautions:** These include, but are not limited to:

- Checking for obstructions in crane rotation
- Checking that all bolts are tight and have lockwashers
- Making sure that endstop is in place
- Making sure that festooning cannot be snagged or pinched

For additional safety precautions see page 18.

## WARNINGS

1. Only competent erection personnel familiar with standard fabrication practices should be employed to assemble these cranes because of the necessity of properly interpreting these instructions. Gorbel is not responsible for the quality of workmanship employed in the installation of a crane according to these instructions. Contact Gorbel, Inc., at 600 Fishers Run, P.O. Box 593, Fishers, New York 14453-0593, 1-800-821-0086, for additional information if necessary.
2. Equipment described herein is not designed for, and should not be used for, lifting, supporting or transporting humans. Failure to comply with any one of the limitations noted herein can result in serious bodily injury and/or property damage. Check Federal, State and Local regulations for any additional requirements.
3. Consult a qualified structural engineer to determine if your support structure is adequate to support the loads generated by thrust and pull (wall/column mounted), or anchor bolt force, overturning moment, or axial load (free standing) of your crane.
4. Crane cannot be utilized as a ground: A separate ground wire is required. For example, systems with 3 phase power require 3 conductors plus one ground wire.
5. Reference American Institute of Steel Construction (AISC) Manual of Steel Construction (9th edition), Part 5, Specification for Structural Joints using ASTM A325 or A490 Bolts (Section 8.d.2) for proper procedures to follow when using any torque tightening method.
6. Do not field modify crane in any way. Any modifications without the written consent of Gorbel, Inc., will void warranty.
7. Unless otherwise specifically stated, Gorbel® parts and products are designed for indoor use. Storing and/or using your items outside (even if covered), exposed to the elements, or in any method other than intended, may void all or some of the product warranty. Always store Gorbel® parts and products indoors, in a cool and dry area.

# INSTALLATION

## STEP 1 - PRE-ASSEMBLY

➔ **TIP:** Packing list can be found in plastic pocket inside hardware box: General Arrangement Drawing can be found inserted in this installation manual.

- 1.1 Read entire manual **before** installing the crane.
- 1.2 Check packing list to ensure no parts have been lost prior to initiating assembly of crane.
- 1.3 Tools and materials (by others) typically needed to assemble crane:
  - Torque wrench
  - Hand tools
  - Allen wrench (1/4")
  - Lifting device to lift heavy masts and booms
  - WSJ200 mounting bolts (by others, Ø 5/8" Grade 5 or better)
  - WSJ360 anchor bolts (by others, Grade 5 or better), refer to pages 5-9 for specifications
  - Grout (Non-Shrink Precision Grout for WSJ360)
  - Ladders/man lifts
  - Heavy duty drill
  - Leveling tools (plumb bob, plumb fixture-pg. 10)

1.4 Identify crane type:

### WARNING

Consult a qualified structural engineer to determine that your support structure is adequate to support the loads generated by thrust and pull (wall/column mounted) or anchor bolt force, overturning moment, or axial load (free standing) of your crane.

#### Wall/Column Mounted Crane (diagram 1A)

Refer to **Chart 1A** to determine thrust and pull, and distance between pivot mounting assembly (bracket) centers, then proceed to **Step 2**, page 4.

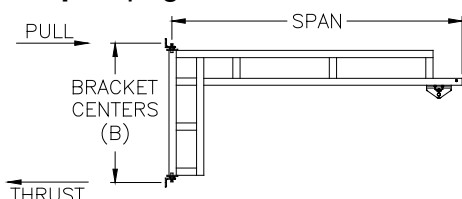


Diagram 1A. Wall/Column Mounted Crane.

#### Free Standing Crane (diagram 1B)

Refer to **Chart 1B**, on page 3, to determine anchor bolt load and footer width and depth, then proceed to **Step 3**, page 5.

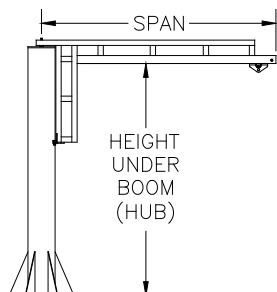


Diagram 1B. Free Standing Crane.

CAPACITY	SPAN (ft)	MODEL NUMBER	TRACK SERIES	B* (in)	THRUST & PULL
100#	4'	WSJ200-100-4	250	36.25"	185 #
	6'	WSJ200-100-6	250	36.25"	306 #
	8'	WSJ200-100-8	250	36.25"	437 #
	10'	WSJ200-100-10	250	36.25"	579 #
	12'	WSJ200-100-12	250	48.25"	549 #
	14'	WSJ200-100-14	250	48.25"	672 #
150#	16'	WSJ200-100-16	250	48.25"	803 #
	4'	WSJ200-150-4	250	36.25"	267 #
	6'	WSJ200-150-6	250	36.25"	434 #
	8'	WSJ200-150-8	250	36.25"	612 #
	10'	WSJ200-150-10	250	36.25"	801 #
	12'	WSJ200-150-12	250	48.25"	750 #
250#	14'	WSJ200-150-14	500	60.25"	782 #
	16'	WSJ200-150-16	500	60.25"	932 #
	4'	WSJ200-250-4	250	36.25"	430 #
	6'	WSJ200-250-6	250	36.25"	691 #
	8'	WSJ200-250-8	250	36.25"	962 #
	10'	WSJ200-250-10	250	48.25"	933 #
500#	12'	WSJ200-250-12	500	60.25"	945 #
	14'	WSJ200-250-14	500	60.25"	1,160 #
	16'	WSJ200-250-16	500	60.25"	1,366 #
	4'	WSJ200-500-4	500	36.25"	843 #
	6'	WSJ200-500-6	500	36.25"	1,342 #
	8'	WSJ200-500-8	500	48.25"	1,390 #
1000#	10'	WSJ200-500-10	500	48.25"	1,784 #
	12'	WSJ200-500-12	500	60.25"	1,750 #
	14'	WSJ200-500-14	1000	60.25"	2,152 #
	16'	WSJ200-500-16	1000	60.25"	2,512 #
	4'	WSJ200-1000-4	1000	36.25"	1,666 #
	6'	WSJ200-1000-6	1000	36.25"	2,639 #
1000#	8'	WSJ200-1000-8	1000	48.25"	2,722 #
	10'	WSJ200-1000-10	1000	60.25"	2,781 #
	12'	WSJ200-1000-12	1000	60.25"	3,394 #
	14'	WSJ200-1000-14	2000	72.25"	3,451 #
	16'	WSJ200-1000-16	2000	72.25"	4,010 #

\*This column provides the distance between pivot mounting assembly (bracket) centers.

**Chart 1A.** Chart for determining thrust and pull, and pivot mounting (bracket) centers.

CAPACITY	HUB	SPAN	MODEL NUMBER	TRACK SERIES	FOOTER DEPTH (L)	FOOTER WIDTH (M)	MAST DIA.	ANCHOR BOLT LOAD	HUB	SPAN	MODEL NUMBER	TRACK SERIES	FOOTER DEPTH (L)	FOOTER WIDTH (M)	MAST DIA.	ANCHOR BOLT LOAD
100#	8'	4'	WSJ360-100-8-4	250	6"	48"	6-5/8"	240 #	12'	4'	WSJ360-100-12-4	250	6"	48"	6-5/8"	240 #
		6'	WSJ360-100-8-6	250	6"	48"	6-5/8"	420 #		6'	WSJ360-100-12-6	250	6"	48"	6-5/8"	420 #
		8'	WSJ360-100-8-8	250	6"	48"	6-5/8"	615 #		8'	WSJ360-100-12-8	250	6"	48"	6-5/8"	615 #
		10'	WSJ360-100-8-10	250	6"	48"	6-5/8"	822 #		10'	WSJ360-100-12-10	250	6"	48"	6-5/8"	822 #
		12'	WSJ360-100-8-12	250	6"	48"	6-5/8"	1,047 #		12'	WSJ360-100-12-12	250	6"	48"	6-5/8"	1,047 #
		14'	WSJ360-100-8-14	250	6"	48"	6-5/8"	1,289 #		14'	WSJ360-100-12-14	250	6"	48"	6-5/8"	1,289 #
	16'	WSJ360-100-8-16	250	6"	48"	6-5/8"	1,547 #	16'	WSJ360-100-12-16	250	6"	48"	8-5/8"	1,547 #		
	10'	4'	WSJ360-100-10-4	250	6"	48"	6-5/8"	240 #	14'	4'	WSJ360-100-14-4	250	6"	48"	6-5/8"	240 #
		6'	WSJ360-100-10-6	250	6"	48"	6-5/8"	420 #		6'	WSJ360-100-14-6	250	6"	48"	6-5/8"	420 #
		8'	WSJ360-100-10-8	250	6"	48"	6-5/8"	615 #		8'	WSJ360-100-14-8	250	6"	48"	6-5/8"	615 #
		10'	WSJ360-100-10-10	250	6"	48"	6-5/8"	822 #		10'	WSJ360-100-14-10	250	6"	48"	6-5/8"	822 #
		12'	WSJ360-100-10-12	250	6"	48"	6-5/8"	1,047 #		12'	WSJ360-100-14-12	250	6"	48"	8-5/8"	1,047 #
14'		WSJ360-100-10-14	250	6"	48"	6-5/8"	1,289 #	14'		WSJ360-100-14-14	250	6"	48"	8-5/8"	1,289 #	
16'	WSJ360-100-10-16	250	6"	48"	6-5/8"	1,547 #	16'	WSJ360-100-14-16	250	6"	48"	8-5/8"	1,547 #			
150#	8'	4'	WSJ360-150-8-4	250	6"	48"	6-5/8"	348 #	12'	4'	WSJ360-150-12-4	250	6"	48"	6-5/8"	348 #
		6'	WSJ360-150-8-6	250	6"	48"	6-5/8"	595 #		6'	WSJ360-150-12-6	250	6"	48"	6-5/8"	595 #
		8'	WSJ360-150-8-8	250	6"	48"	6-5/8"	857 #		8'	WSJ360-150-12-8	250	6"	48"	6-5/8"	857 #
		10'	WSJ360-150-8-10	250	6"	48"	6-5/8"	1,137 #		10'	WSJ360-150-12-10	250	6"	48"	6-5/8"	1,137 #
		12'	WSJ360-150-8-12	250	6"	48"	6-5/8"	1,432 #		12'	WSJ360-150-12-12	250	6"	48"	6-5/8"	1,432 #
		14'	WSJ360-150-8-14	500	6"	48"	6-5/8"	1,873 #		14'	WSJ360-150-12-14	500	6"	48"	8-5/8"	1,873 #
	16'	WSJ360-150-8-16	500	6"	48"	8-5/8"	2,242 #	16'	WSJ360-150-12-16	500	6"	48"	8-5/8"	2,242 #		
	10'	4'	WSJ360-150-10-4	250	6"	48"	6-5/8"	348 #	14'	4'	WSJ360-150-14-4	250	6"	48"	6-5/8"	348 #
		6'	WSJ360-150-10-6	250	6"	48"	6-5/8"	595 #		6'	WSJ360-150-14-6	250	6"	48"	8-5/8"	595 #
		8'	WSJ360-150-10-8	250	6"	48"	6-5/8"	857 #		8'	WSJ360-150-14-8	250	6"	48"	8-5/8"	857 #
		10'	WSJ360-150-10-10	250	6"	48"	6-5/8"	1,137 #		10'	WSJ360-150-14-10	250	6"	48"	8-5/8"	1,137 #
		12'	WSJ360-150-10-12	250	6"	48"	6-5/8"	1,432 #		12'	WSJ360-150-14-12	250	6"	48"	8-5/8"	1,432 #
14'		WSJ360-150-10-14	500	6"	48"	6-5/8"	1,873 #	14'		WSJ360-150-14-14	500	6"	48"	8-5/8"	1,873 #	
16'	WSJ360-150-10-16	500	6"	48"	8-5/8"	2,242 #	16'	WSJ360-150-14-16	500	6"	48"	8-5/8"	2,242 #			
250#	8'	4'	WSJ360-250-8-4	250	6"	48"	6-5/8"	558 #	12'	4'	WSJ360-250-12-4	250	6"	48"	6-5/8"	558 #
		6'	WSJ360-250-8-6	250	6"	48"	6-5/8"	945 #		6'	WSJ360-250-12-6	250	6"	48"	6-5/8"	945 #
		8'	WSJ360-250-8-8	250	6"	48"	6-5/8"	1,347 #		8'	WSJ360-250-12-8	250	6"	48"	8-5/8"	1,347 #
		10'	WSJ360-250-8-10	250	6"	48"	6-5/8"	1,767 #		10'	WSJ360-250-12-10	250	6"	48"	8-5/8"	1,767 #
		12'	WSJ360-250-8-12	500	6"	60"	8-5/8"	955 #		12'	WSJ360-250-12-12	500	6"	60"	8-5/8"	955 #
		14'	WSJ360-250-8-14	500	6"	66"	8-5/8"	1,186 #		14'	WSJ360-250-12-14	500	6"	66"	8-5/8"	1,186 #
	16'	WSJ360-250-8-16	500	6"	66"	8-5/8"	1,410 #	16'	WSJ360-250-12-16	500	6"	66"	12-3/4"	1,410 #		
	10'	4'	WSJ360-250-10-4	250	6"	48"	6-5/8"	558 #	14'	4'	WSJ360-250-14-4	250	6"	48"	8-5/8"	558 #
		6'	WSJ360-250-10-6	250	6"	48"	6-5/8"	945 #		6'	WSJ360-250-14-6	250	6"	48"	8-5/8"	945 #
		8'	WSJ360-250-10-8	250	6"	48"	8-5/8"	1,347 #		8'	WSJ360-250-14-8	250	6"	48"	8-5/8"	1,347 #
		10'	WSJ360-250-10-10	250	6"	48"	8-5/8"	1,767 #		10'	WSJ360-250-14-10	250	6"	48"	8-5/8"	1,767 #
		12'	WSJ360-250-10-12	500	6"	60"	8-5/8"	955 #		12'	WSJ360-250-14-12	500	6"	60"	12-3/4"	955 #
14'		WSJ360-250-10-14	500	6"	66"	8-5/8"	1,186 #	14'		WSJ360-250-14-14	500	6"	66"	12-3/4"	1,186 #	
16'	WSJ360-250-10-16	500	6"	66"	8-5/8"	1,410 #	16'	WSJ360-250-14-16	500	6"	66"	12-3/4"	1,410 #			
500#	8'	4'	WSJ360-500-8-4	500	6"	48"	8-5/8"	1,088 #	12'	4'	WSJ360-500-12-4	500	6"	48"	8-5/8"	1,088 #
		6'	WSJ360-500-8-6	500	6"	48"	8-5/8"	1,831 #		6'	WSJ360-500-12-6	500	6"	48"	8-5/8"	1,831 #
		8'	WSJ360-500-8-8	500	6"	60"	8-5/8"	1,071 #		8'	WSJ360-500-12-8	500	6"	60"	12-3/4"	1,071 #
		10'	WSJ360-500-8-10	500	6"	66"	12-3/4"	1,417 #		10'	WSJ360-500-12-10	500	6"	66"	12-3/4"	1,417 #
		12'	WSJ360-500-8-12	500	6"	69"	12-3/4"	1,771 #		12'	WSJ360-500-12-12	500	6"	69"	12-3/4"	1,771 #
		14'	WSJ360-500-8-14	1000	48"	48"	12-3/4"	2,201 #		14'	WSJ360-500-12-14	1000	48"	48"	12-3/4"	2,201 #
	16'	WSJ360-500-8-16	1000	48"	48"	12-3/4"	2,594 #	16'	WSJ360-500-12-16	1000	48"	48"	14"	2,594 #		
	10'	4'	WSJ360-500-10-4	500	6"	48"	8-5/8"	1,088 #	14'	4'	WSJ360-500-14-4	500	6"	48"	12-3/4"	407 #
		6'	WSJ360-500-10-6	500	6"	48"	8-5/8"	1,831 #		6'	WSJ360-500-14-6	500	6"	48"	12-3/4"	735 #
		8'	WSJ360-500-10-8	500	6"	60"	8-5/8"	1,071 #		8'	WSJ360-500-14-8	500	6"	60"	12-3/4"	1,072 #
		10'	WSJ360-500-10-10	500	6"	66"	12-3/4"	1,417 #		10'	WSJ360-500-14-10	500	6"	66"	12-3/4"	1,417 #
		12'	WSJ360-500-10-12	500	6"	69"	12-3/4"	1,771 #		12'	WSJ360-500-14-12	500	6"	69"	12-3/4"	1,772 #
14'		WSJ360-500-10-14	1000	48"	48"	12-3/4"	2,201 #	14'		WSJ360-500-14-14	1000	48"	48"	12-3/4"	2,201 #	
16'	WSJ360-500-10-16	1000	48"	48"	12-3/4"	2,594 #	16'	WSJ360-500-14-16	1000	48"	48"	14"	2,037 #			
1000#	8'	4'	WSJ360-1000-8-4	1000	48"	48"	12-3/4"	797 #	12'	4'	WSJ360-1000-12-4	1000	48"	48"	12-3/4"	797 #
		6'	WSJ360-1000-8-6	1000	48"	48"	12-3/4"	1,434 #		6'	WSJ360-1000-12-6	1000	48"	48"	12-3/4"	1,441 #
		8'	WSJ360-1000-8-8	1000	48"	48"	12-3/4"	2,083 #		8'	WSJ360-1000-12-8	1000	48"	48"	12-3/4"	1,611 #
		10'	WSJ360-1000-8-10	1000	48"	48"	12-3/4"	2,739 #		10'	WSJ360-1000-12-10	1000	48"	48"	12-3/4"	2,142 #
		12'	WSJ360-1000-8-12	1000	48"	48"	12-3/4"	3,405 #		12'	WSJ360-1000-12-12	1000	48"	48"	12-3/4"	2,681 #
		14'	WSJ360-1000-8-14	2000	48"	60"	14"	3,354 #		14'	WSJ360-1000-12-14	2000	48"	60"	14"	3,354 #
	16'	WSJ360-1000-8-16	2000	48"	60"	14"	3,953 #	16'	WSJ360-1000-12-16	2000	48"	60"	16"	3,953 #		
	10'	4'	WSJ360-1000-10-4	1000	48"	48"	12-3/4"	797 #	14'	4'	WSJ360-1000-14-4	1000	48"	48"	12-3/4"	797 #
		6'	WSJ360-1000-10-6	1000	48"	48"	12-3/4"	1,434 #		6'	WSJ360-1000-14-6	1000	48"	48"	12-3/4"	1,434 #
		8'	WSJ360-1000-10-8	1000	48"	48"	12-3/4"	2,083 #		8'	WSJ360-1000-14-8	1000	48"	48"	14"	2,083 #
		10'	WSJ360-1000-10-10	1000	48"	48"	12-3/4"	2,739 #		10'	WSJ360-1000-14-10	1000	48"	48"	14"	2,739 #
		12'	WSJ360-1000-10-12	1000	48"	48"	12-3/4"	3,405 #		12'	WSJ360-1000-14-12	1000	48"	48"	14"	3,405 #
14'		WSJ360-1000-10-14	2000	48"	60"	14"	3,354 #	14'		WSJ360-1000-14-14	2000	48"	60"	14"	3,354 #	
16'	WSJ360-1000-10-16	2000	48"	60"	14"	3,953 #	16'	WSJ360-1000-14-16	2000	48"	60"	16"	3,953 #			

\*See pages 5 and 6 for additional information on footer requirements.

Chart 1B. Chart for determining footer depth, footer width and anchor bolt load.

## STEP 2 - WSJ200 (WALL/COLUMN MOUNTED) BOOM INSTALLATION

➔ **TIP:** The upper fitting will have slotted mounting holes. The lower fitting has round mounting holes and a ridge in the bearing housing to accept the friction brake.

### STOP!

Do not proceed if your support structure does not meet the loading requirements determined in Step 1.4.

**2.1** Determine position of **upper** pivot mounting assembly on support structure, and drill bolt holes. **Temporarily** bolt upper pivot mounting assembly to support structure (**do not** use lockwashers).

**2.2** Determine position of **lower** pivot mounting assembly by dropping plumb bob (by others) through pivot holes (**diagram 2A**).

**2.3** Drill bolt holes and bolt **lower** pivot mounting assembly to support structure. **Do not** torque bolts until boom weldment has been installed.

**2.4** Remove upper pivot mounting assembly from support structure.

**2.5** Clean pivot pins with clean, dry cloth. Slide bearings on pivot pins. Be sure to orient bearings correctly (**diagram 2B**).

**Note:** If you have Friction Brakes, refer to Step 8, page 14, for installation instructions before proceeding.

**2.6** Lift boom weldment up and insert lower pivot pin into **lower** pivot mounting assembly (**diagram 2C**).

**2.7** Place **upper** pivot mounting assembly on upper pivot pin of boom weldment (**diagram 2D**). Bolt **upper** pivot mounting assembly to support structure.

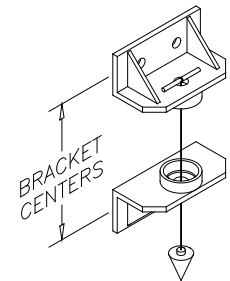
**2.8** At 45° intervals, check that **pivot pins** of crane are plumb. Shimming of upper and/or lower pivot mounting assembly may be required (shims included).

**2.9** Once mast is plumb and shimmed, tighten all mounting bolts to manufacturer's specifications.

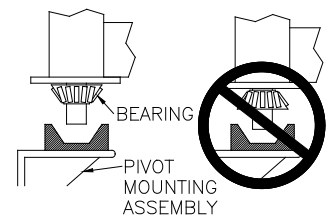
**2.10** Carefully swing boom through entire travel to ensure boom is clear of obstructions and does not drift.

**If boom drifts**, support structure may be inadequate and/or pivot mounting assemblies may not be aligned (refer to **Step 2.2** for pivot mounting assembly alignment).

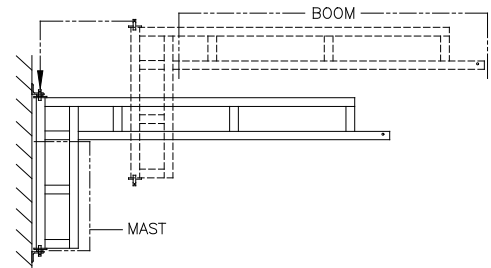
**2.11** Proceed to **Step 5**, on page 12.



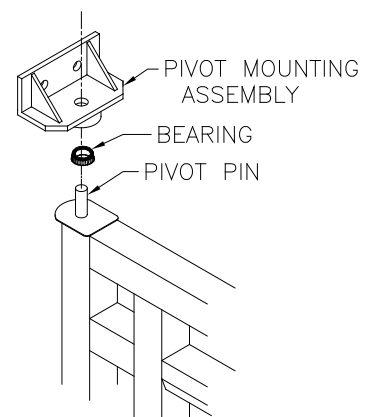
**Diagram 2A.** Plumbing pivot mounting assemblies.



**Diagram 2B.** Orienting bearing.



**Diagram 2C.** Installing boom weldment.



**Diagram 2D.** Installing upper pivot mounting assembly.

## STEP 3 - WSJ360 (FREE STANDING) MAST INSTALLATION

➔ **TIP:** Square base plates **do not** have triangular gussets.

### STOP!

Do not proceed if your support structure does not meet the loading requirements determined in **Step 1.4.**

### 3.1 INSTALLING ANCHOR BOLTS

#### 3.1.1 Square Base Plates (4-bolt pattern):

- A) Install 3/4" Gorbels supplied Hilti anchors per 3.1.4.  
 B) Anchor bolts (by others) for **square** base plates must:

- be 1" in diameter.

**Note:** Only cranes with 1-1/4" diameter holes in the baseplate or baseplate stiffener are sized for 1" anchor bolts.

- be embedded at least 4-1/2" into floor, not to exceed 3/4 of floor depth (see diagram 3A).

**Note:** A minimum 6" thick reinforced concrete floor is required.

- have **minimum** of two threads above nut after installation

**Note:** Work Station Jib Crane foundation requirements are based on soil pressure of 2500# per square foot. Concrete pressure recommended for jib crane foundation is 3000# per square inch of compressive force, with no cracks or seams in a 48" square area around center of mast.

**Note:** Foundationless Work Station Jib Cranes should be mounted to a shallow foundation, centered on a square foot area that is free from cracks, seams and walls and mounted with chemical anchor bolts to withstand a minimum of 3470# of pull out force.

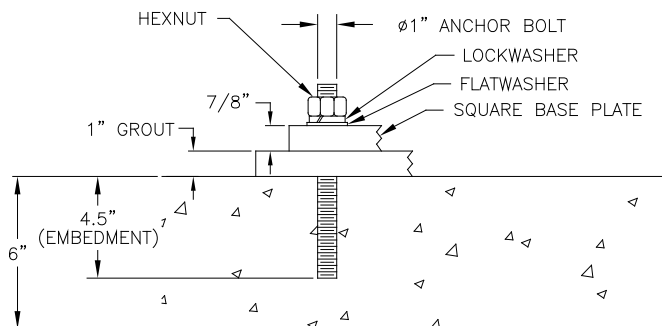
**Note:** Chemical (epoxy) anchor bolts are recommended because of their ability to withstand the vibrating loads caused by the hoist stopping and starting under load.

- C) Drill holes in concrete floor using pre-drilled holes in base plate or **diagram 3B** as a guide (use drill bit size recommended by anchor bolt manufacturer).

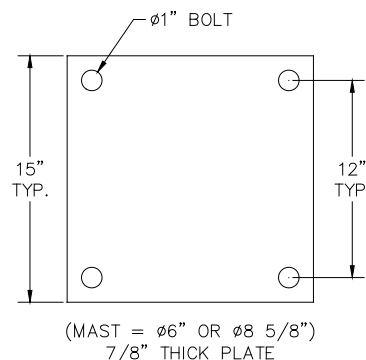
- D) Install anchor bolts (Grade 5 or better) and hardware (by others) according to manufacturer's installation directions and requirements.

- E) Proceed to **Step 3.2**, page 10, for mast installation and plumbing.

**WARNING**  
**Diagram 3A is for square base plates only!**



**Diagram 3A.** Typical square base plate anchor bolt embedment.



**Diagram 3B.** Square base plate pattern.

# STEP 3 - WSJ360 (FREE STANDING) MAST INSTALLATION (CONTINUED)

➡ **TIP:** Anchor bolts (J bolts) typically protrude 6" above foundation before mast is installed.

## STOP!

Do not proceed if your support structure does not meet the loading requirements identified in **Step 1.4**.

### 3.1 INSTALLING ANCHOR BOLTS (CONTINUED)

#### 3.1.2 Hexagonal Base Plates for Poured Foundations (6 or 12 bolt pattern):

Refer to **Chart 3A** for Base Plate Thickness

### WARNING

Consult a qualified structural engineer if you deviate from the recommended dimensions provided in this manual. Gorbel, Inc. is not responsible for any deviation from these foundation recommendations.

A) Anchor bolts (by others) for **hexagonal** base plates must:

- be diameter as specified in **diagram 3C, 3D or 3E**.
- be embedded 3/4 of footer depth (L).
- have **minimum** of two threads above nut after installation.

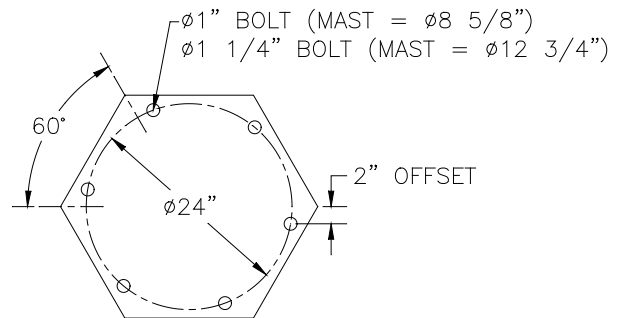


Diagram 3C. 6 bolt base bolt pattern.

B) Create steel-reinforced concrete foundation using recommendations shown in **diagram 3F**.

Refer to **Chart 1B**, page 3, for footer depth (L) and footer width (M) in **diagram 3F**.

**Note:** Jib crane foundation requirements are based on soil pressure of 2500# per square foot. Concrete pressure recommended for jib crane foundation is 3000# per square inch of compressive force.

**Note:** Foundation/concrete must cure seven (7) days prior to mast installation. Foundation/concrete must cure 28 days prior to using crane to full capacity.

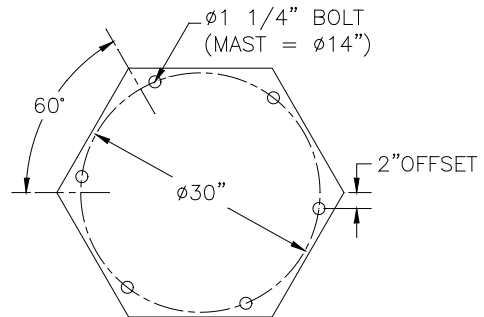


Diagram 3D. 6 bolt base bolt pattern.

C) Proceed to **Step 3.2**, page 10, for mast installation and plumbing.

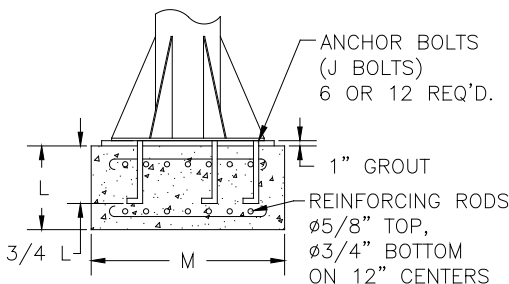


Diagram 3F. Hexagonal base plate foundation.

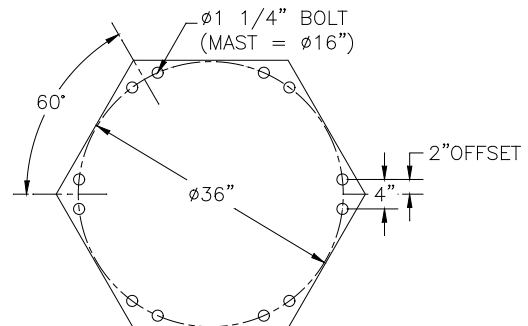


Diagram 3E. 12 bolt base bolt pattern.

Mast Size	8-5/8	12-3/4	14	16
Base Plate Thickness	1/2"	1/2"	1/2"	1/2"

Chart 3A. Base plate thickness.

## STEP 3 - WSJ 360 (FREE STANDING) MAST INSTALLATION (CONTINUED)

➔ **TIP:** Anchor bolts (J bolts) typically protrude 6" above foundation before mast is installed.

### 3.1 INSTALLING ANCHOR BOLTS (CONTINUED)

#### 3.1.3 Hexagonal Base Plates for Foundationless Jibs (6 bolt pattern):

For jib cranes that can be mounted on a 6" foundation that is free of cracks, seams, expansion joints, and walls (*chart 3B*).

#### WARNING

Consult a qualified structural engineer if you deviate from the recommended dimensions provided in this manual. Gorbels, Inc. is not responsible for any deviation from these foundation recommendations.

A) Anchor bolts (by others) for hexagonal base plates must:

- be 3/4" in diameter (*diagram 3G*).

**Note:** Jib cranes that have an NP6 designation have a special design that is different than standard Work Station Jib Cranes for poured foundations. The NP6 base plate stiffener allows for a 3/4" diameter anchor bolt as opposed to the standard baseplate stiffener that allows for a 1-1/4" diameter anchor bolt. If you have a standard design WSJ for a poured foundation refer to Step 3.1.2. Contact Gorbels® Customer Service if you are unsure what style (NP6 or Standard) Work Station Jib Crane you have.

- be embedded at least 4" into the floor, not to exceed 3/4 of the foundation depth.

**Note: A minimum 6" thick reinforced concrete floor is required.**

- have **minimum** of two threads above nut after installation.

**Note:** Jib crane foundation requirements are based on soil pressure of 2500# per square foot. Concrete pressure recommended for jib crane foundation is 3000# per square inch of compressive force.

**Note:** Foundationless Work Station Jib Cranes should be mounted to a shallow foundation, centered on a square foot area that is free from cracks, seams and walls mounted with chemical anchor bolts to withstand a minimum of 3470# of pull out force.

**Note:** Chemical (epoxy) anchor bolts are recommended because of their ability to withstand the vibrating loads caused by the hoist stopping and starting under load.

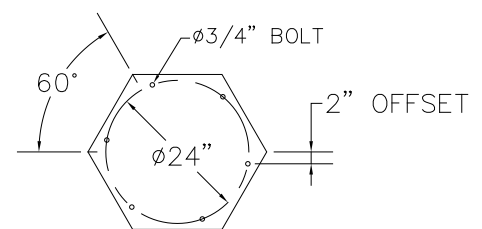
B) Drill holes in concrete floor using pre-drilled holes in base plate or *diagram 3G* as a guide (use drill bit size recommended by anchor bolt manufacturer).

C) Install anchor bolts (Grade 5 or better) and hardware (by others) according to manufacturer's installation directions and requirements.

D) Proceed to **Step 3.2**, page 10, for mast installation and plumbing.

Capacity	Span	Foundation size (sq. ft.)
≤ 250#	4' - 6'	5' x 5'
	7' - 9'	6' x 6'
	10' - 14'	7' x 7'
	15' - 16'	8' x 8'
≤ 500# to < 1000#	4'	5' x 5'
	5' - 6'	6' x 6'
	7' - 9'	7' x 7'
	10' - 12'	8' x 8'
1000#	13' - 16'	9' x 9'
	4'	6' x 6'
	5' - 6'	7' x 7'
	7' - 8'	8' x 8'
	9' - 11'	9' x 9'
	12' - 14'	10' x 10'
	15' - 16'	11' x 11'

**Chart 3B.** Distance of jib from cracks, seams, walls.



**Diagram 3G.** 6 bolt base bolt pattern.

## STEP 3 - WSJ360 (FREE STANDING) MAST INSTALLATION (CONTINUED)

### 3.1 INSTALLING ANCHOR BOLTS (CONTINUED)

#### 3.1.4 Base Plates for Foundationless Jibs (Gorbel supplied anchors):

For jib cranes that can be mounted on a 6" foundation that is free of cracks, seams, expansion joints, and walls (**chart 3B**).

**Note:** Jib cranes that have an NP6 designation have a special design that is different than standard Work Station Jib Cranes for poured foundations. The NP6 baseplate stiffener allows for a 3/4" diameter anchor bolt as opposed to the standard baseplate stiffener that allows for a 1-1/4" diameter anchor bolt. If you have a standard design WSJ for a poured foundation refer to Step 3.1.2. Contact Gorbel® Customer Service if you are unsure what style (NP6 or Standard) Work Station Jib Crane you have.

### WARNING

Consult a qualified structural engineer if you deviate from the recommended dimensions provided in this manual. Gorbel, Inc. is not responsible for any deviation from these foundation recommendations.

A) **Gorbel Foundationless Jibs (Gorbel supplied anchors)** are designed for use with:

- HILTI Epoxy - HIT-HY 200-A
- HILTI Anchors - HAS-B-105

B) Anchor bolts (by HILTI) for round base plates must:

- be embedded at least 4" into the floor, not to exceed 3/4 of the foundation depth.
- have **minimum** of two threads above nut after installation.

**Note: A minimum 6" thick reinforced concrete floor is required.**

**Note:** Jib crane foundation requirements are based on soil pressure of 2500# per square foot. Concrete pressure recommended for jib crane foundation is 3000# per square inch of compressive force.

- centered on a square foot area (**chart 3B**) that is free from cracks, seams and walls mounted with chemical anchor bolts with a minimum bond strength of 4,000 lbs.

C) Drill 7/8" holes in concrete floor using pre-drilled holes in base plate or **diagram 3H** as a guide.

D) Clean dust and debris from the drilled holes.

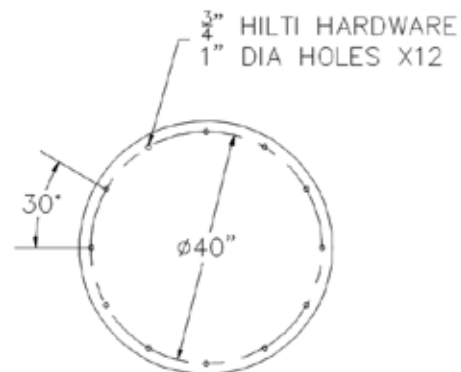
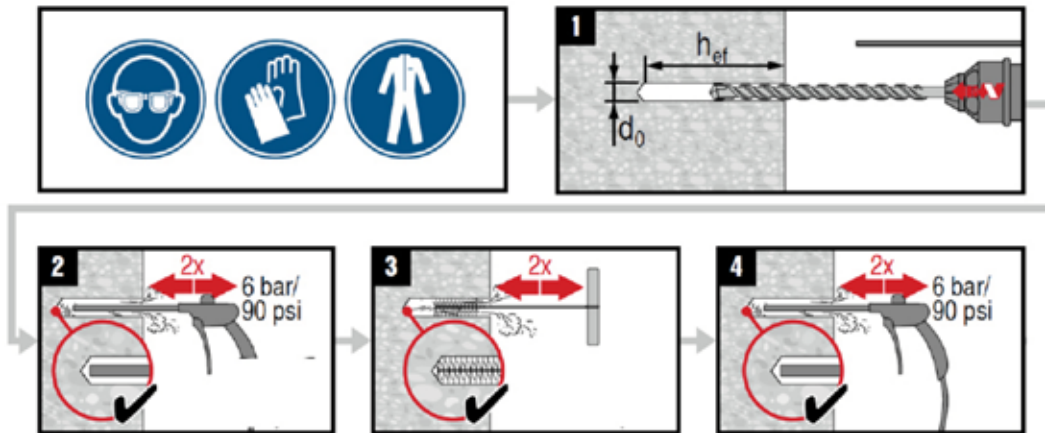
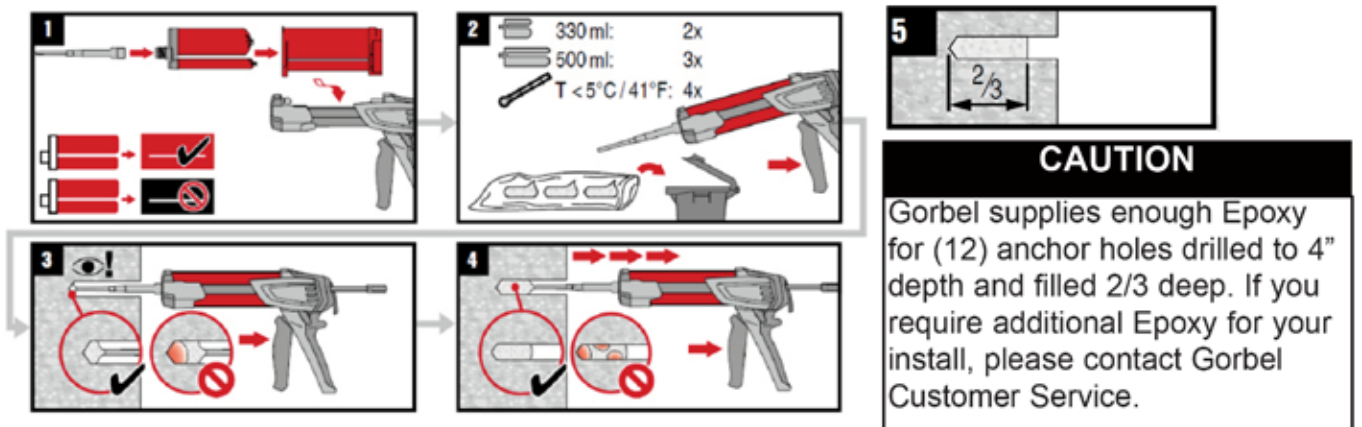


Diagram 3H. 44" dia. 12 bolt base bolt pattern.

# STEP 3 - WSJ 360 (FREE STANDING) MAST INSTALLATION (CONTINUED)

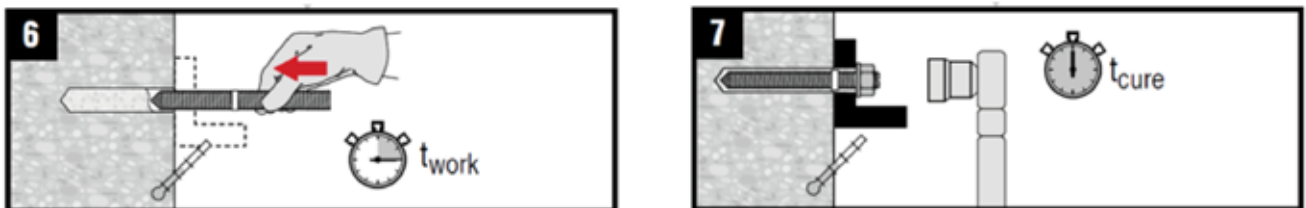


E) Fill the holes to 2/3 depth with specified HILTI Epoxy.



F) Install the specified HILTI Anchors.

G) Allow the Epoxy to fully cure before torquing anchor hardware.



## STEP 3 - WSJ360 (FREE STANDING) MAST INSTALLATION (CONTINUED)

### WARNING

Mast must be plumb to prevent boom from drifting.

### 3.2 INSTALLING AND PLUMBING MAST

- A) Cover entire base plate area with one inch of non-shrink precision grout.
- B) Set mast into place and make sure that the base plate is completely seated in the grout.
- C) Drop plumb line (not included) from top of mast, using fixture (not included) or equivalent (*diagram 3I*).
- D) At point "A", one (1") inch below top mast plate, set plumb line a distance of three (3") inches from surface of mast pipe (*diagram 3J*).
- E) At point "B", four (4') feet below point "A" (approximately where rollers will contact mast pipe), distance between plumb line and face of mast should also be three (3") inches.
- F) Repeat steps D & E every 60° around the mast to ensure that the mast is plumb throughout.

**Note:** Be sure to fasten plumb line securely to plumb fixture so that it will not move. Movement will result in an inaccurate plumb measurement.

- G) Once mast is plumb **and grout has cured**, fully tighten anchor bolt hardware per manufacturer's instructions.

**Note:** If Gorbel is the supplier of the anchor bolts, tighten to full compression of the lockwasher.

- H) Verify mast is still plumb.

**DO NOT USE A LEVEL TO PLUMB MAST.**

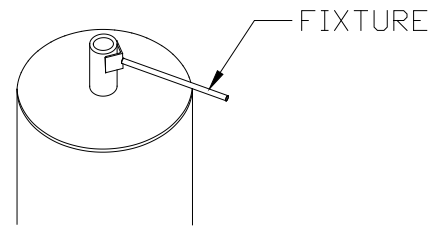


Diagram 3I. Plumbing fixture.

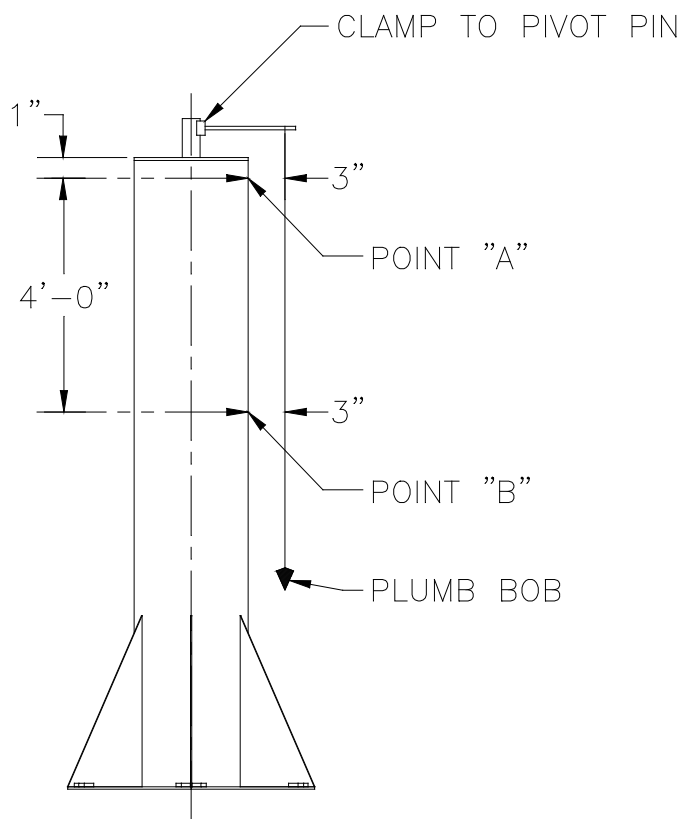
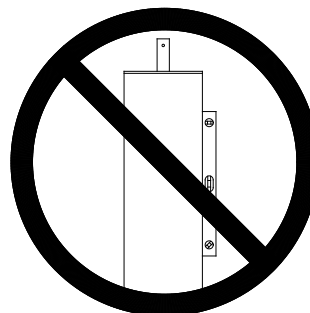


Diagram 3J. Plumbing the mast.



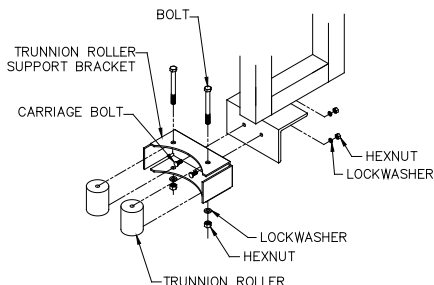
## STEP 4 - WSJ360 (FREE STANDING) BOOM INSTALLATION

**TIP:** Unloaded boom will tilt slightly upward.

- 4.1 Install cam followers/trunnion rollers at bottom of boom assembly (**diagram 4A** or **4B**). Tighten nylock nuts to 50 ft.-lbs. and hexnuts until lockwashers are flat.

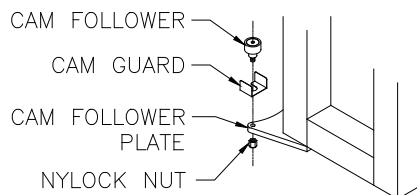
### WARNING

If nylock nut is removed it must be replaced.

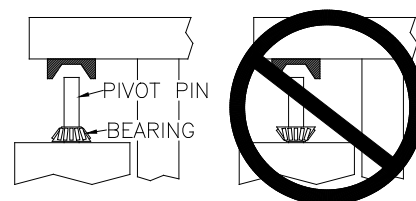


**Diagram 4A.** Installing trunnion rollers.

- 4.2 Place and orient pivot bearing on mast pivot pin (**diagram 4C**).
- 4.3 Place boom assembly over pivot pin on mast. Insert retaining pin through pivot pin and roll O-rings onto retaining pin (**diagram 4D**).



**Diagram 4B.** Installing cam followers.

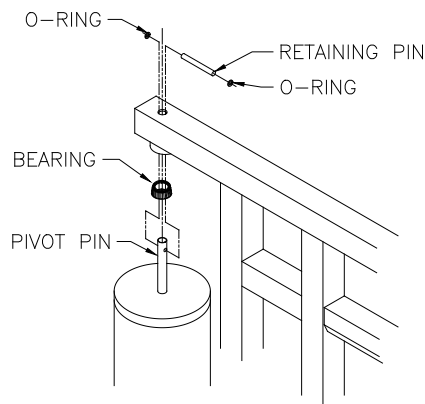


**Diagram 4C.** Orienting bearing.

### WARNING

O-rings must be installed on retaining pin to ensure that retaining pin does not dislodge.

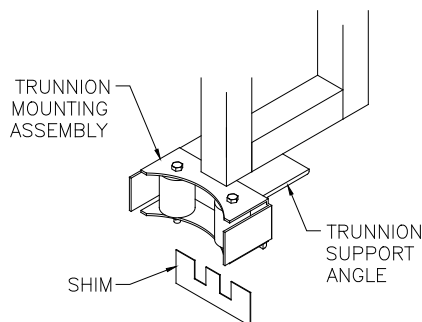
- 4.4 Level boom by shimming between trunnion mounting assembly and trunnion support angle (**diagram 4E**) or by evenly adjusting eccentric cam followers with an allen wrench (**diagram 4F**). Be sure boom is leveled to L/640 of span above level.



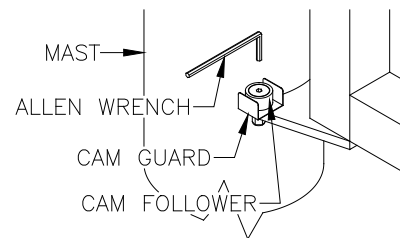
**Diagram 4D.** Installing boom weldment.

- 4.5 Check to make sure that both rollers have full face contact with mast pipe.

Carefully swing boom through entire travel to ensure boom is clear of obstructions and does not drift.



**Diagram 4E.** Adjusting trunnion rollers.



**Diagram 4F.** Adjusting eccentric cam followers.

**If boom drifts**, check to make sure that cam followers/trunnion rollers are evenly adjusted and/or mast is plumb.

## STEP 5 - HOIST TROLLEY INSTALLATION

➡ **TIP:** If you have festooning, it must be installed before hoist trolley.

- 5.1 If you have festooning (optional), slide in festoon clamp/vacuum hose clamp and bolt into place; slide festoon gliders/trolleys through open end of boom track (**diagram 5A**).

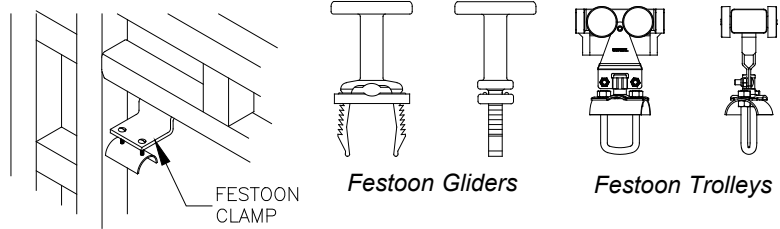
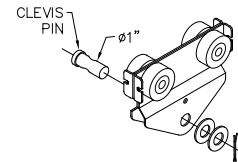
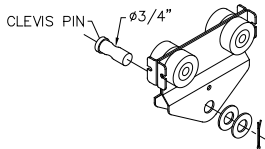
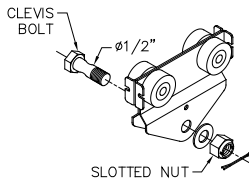


Diagram 5A. Installing festoon clamp and festoon gliders/trolleys.

- 5.2 Attach hoist to hoist trolley by snapping hoist suspension hook over trolley saddle clevis pin of hoist trolley.

If hoist suspension hook is too large or if hoist has suspension device other than a hook, remove trolley saddle clevis pin and install suspension device. Insert clevis pin back in place. Slide washers on clevis pin and insert cotter pin through trolley saddle clevis pin (**diagram 5B, 5C or 5D**).



- 5.3 Diagram 5B. 250 series hoist trolley. Diagram 5C. 500 series hoist trolley. Diagram 5D. 1000, 2000 series hoist trolley.

Bend back both legs of cotter pin (**diagram 5E**).

### WARNING

Fully bend both legs of cotter pin (**diagram 5E**). If cotter pin is cracked or fatigued it must be replaced.

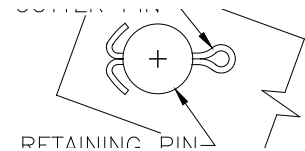


Diagram 5E. Installing cotter pin through trolley saddle clevis pin.

- 5.4 If a tow arm is not being utilized on the trolley, go to Step 5.7. If a tow arm is being utilized on the trolley, got to Step

5.5.

**Note:** Festoon tow arms are **not necessary** for systems with festoon trolleys.

- 5.5 Assemble the tow arm weldment on the festooning end of the hoist trolley (**diagram 5F**).

- 5.6 After the hoist trolley has been installed, loosen nuts on end of U-bolt enough to thread cable/air hose between the two legs of the U-bolt and festoon clamp plate. Secure cable/air hose by tightening nuts at the end of the U-bolt, forcing the festooning clamp plate snug against the cable/air hose.

- 5.7 Roll hoist trolley into open end of track.

Install end stop (molded bumper with thru bolt) in open end of boom track (**diagram 5G**).

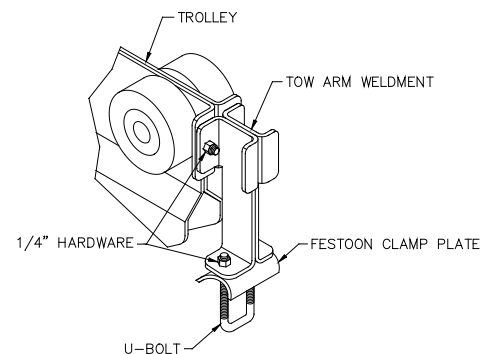


Diagram 5F. Installing tow arm on trolley.

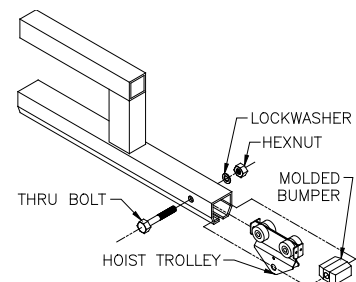


Diagram 5G. Installing hoist trolley and endstop.

## STEP 6 - FESTOONING INSTALLATION (OPTIONAL)

### Installing Festoon Cable/Air Hose/Vacuum Hose:

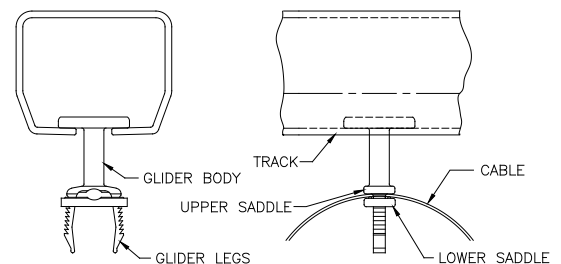
Gliders are designed to accept 4-conductor, electric flat cable (#10, #12, or #14 gauge). Festoon trolleys are designed to accept 4-conductor, electric flat or round cable (#10, #12, or #14 gauge) or air hose (maximum: 7/8" outside diameter).

### WARNING

Crane cannot be utilized as a ground: A separate ground wire is required. For example, systems with 3 phase power require 3 conductors plus one ground wire.

#### Electric Cable with Festoon Gliders

Thread electric cable between upper and lower saddles of glider. Secure electric cable by pushing lower saddle up glider legs, clamping electric cable into place (**diagram 6A**).



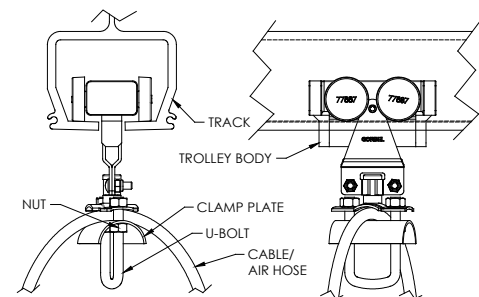
**Diagram 6A.** Installing electric cable on festoon glider.

#### Electric Cable/Air Hose with Festoon Trolleys

Loosen nuts and clamp-plate enough to thread electric cable/air hose between the U-bolt legs and clamp plate on festoon trolley. Secure cable by tightening lower nuts on festoon trolley U-bolt, forcing clamp plate snug up against electric cable/air hose (**diagram 6B**).

**Note:** Ensure U-bolt legs do not interfere with trolley body.

**Note:** Be careful not to tighten bolts too tight; will cause damage to electric cable/air hose.



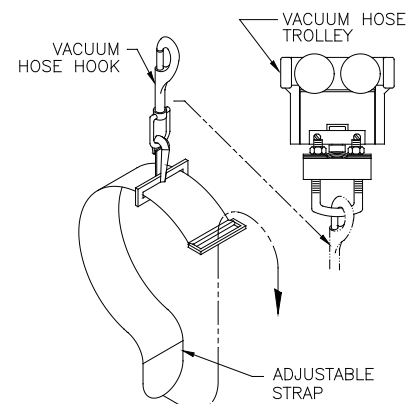
**Diagram 6B.** Installing electric cable/air hose on festoon trolley.

#### Vacuum Hose Trolleys

Place strap around vacuum hose (by others). Secure velcro sides together and be sure vacuum hose is held snugly in place (**diagram 6C**).

Clip vacuum hook (with vacuum hose attached) onto vacuum hose trolley (**diagram 6C**).

**Note:** Strap will fit vacuum hoses with outside diameters ranging from 1-1/2" to 2-3/4".



**Diagram 6C.** Installing hose on vacuum hose trolley.

## STEP 7 - TAGLINE INSTALLATION (OPTIONAL)

- 7.1 Attach tagline brackets to vertical tubes as shown using U-bolts and hardware provided (**diagram 7A**).
- 7.2 Attach eyebolts onto tagline brackets.
- 7.3 Loop cable through eyebolts and overlap by approximately 6". Use cable clamps to secure cable leaving a few inches doubled up.

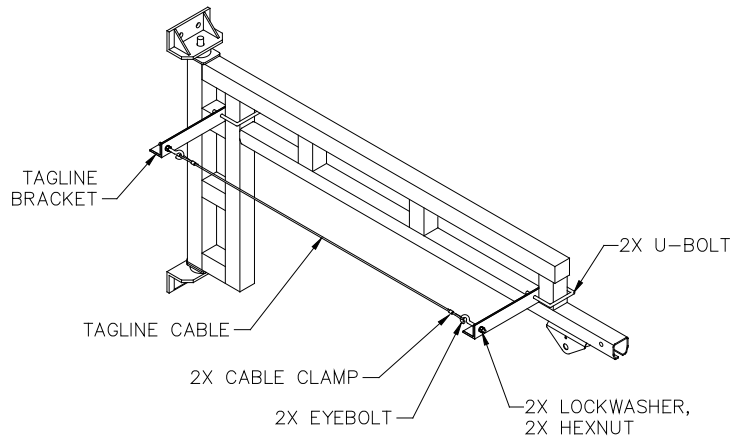


Diagram 7A. Tagline Installation.

## STEP 8 - FRICTION BRAKE INSTALLATION (OPTIONAL)

### WSJ200 Friction Brake Installation (**diagram 8A**)

- A) Attach two brake pads to the lower pivot mounting assembly using two 1/4" socket head cap screws, lock washers and lock nuts (**diagram 8A**).
- B) Adjust brake by tightening two lock nuts to achieve desired rotational resistance of the boom.

### WARNING

Do not exceed maximum torque of 25 in-lb.

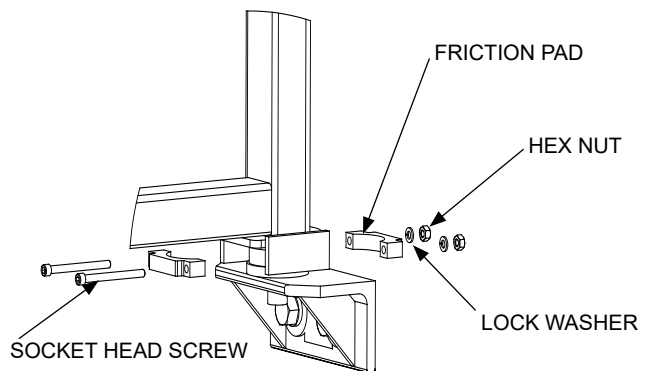


Diagram 8A. Installing friction brakes on Wall Mounted Work Station Jib.

- C) Adjust as often as required.

## STEP 8 - FRICTION BRAKE INSTALLATION (CONTINUED)

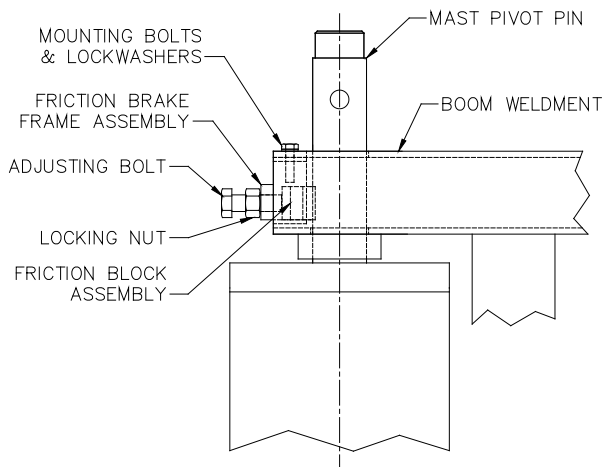
### Retrofitting Friction Brakes on Existing WSJ200

Consult Gobel® Customer Service at 800-821-0086 for further instructions.

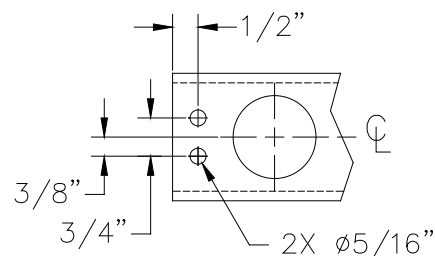
### Installing Friction Brakes on WSJ360 (*diagram 8B*)

**Note:** If friction brake is being retrofit on an existing crane go to Step A. Otherwise proceed to Step B.

- A) Drill two 5/16" diameter holes 1/2" from the end of the top boom tube and 3/8" off each side of center line (*diagram 8C*).
- B) Place nylon brake pad in friction brake frame assembly with the groove positioned vertically and facing the opening.
- C) Turn locking nut onto adjusting bolt as far as possible.
- D) Insert adjusting bolt into friction brake frame (center on back of nylon brake).
- E) Slide brake assembly into end of tube. Line up drilled holes in top tube with tapped holes in friction brake frame.
- F) Screw in two mounting bolts, with lockwashers, until frame is secure against top of boom tube.
- G) Adjust brake by turning the adjusting bolt in or out.
- H) Once desired rotation "speed" is reached, lock adjusting bolt in place with locking nut.



**Diagram 8B.** Installing friction brakes on WSJ360.



**Diagram 8C.** Retrofitting friction brakes on WSJ360.

### WARNING

Do not overtighten bolt.

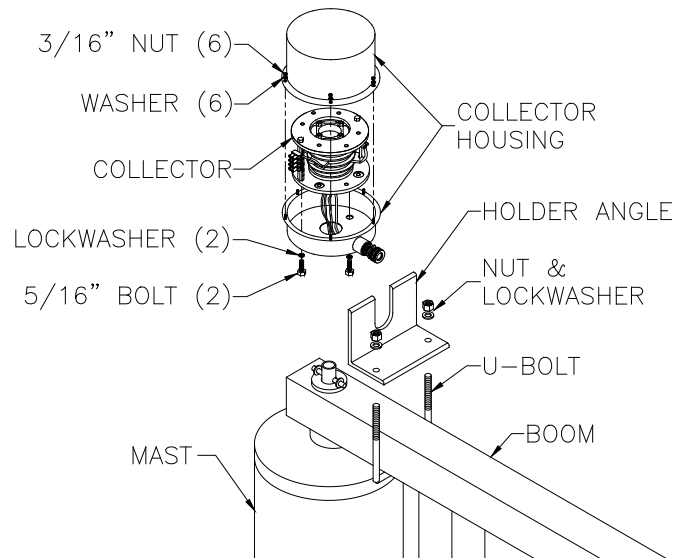
- I) Adjust as often as required.

**Note:** Make sure that Pivot Pin is free of any grease/oils so the Friction Brake can work correctly.

## STEP 9 - ACCESSORIES (OPTIONAL)

### Electrical Bottom Entry Collector (*diagram 9A*)

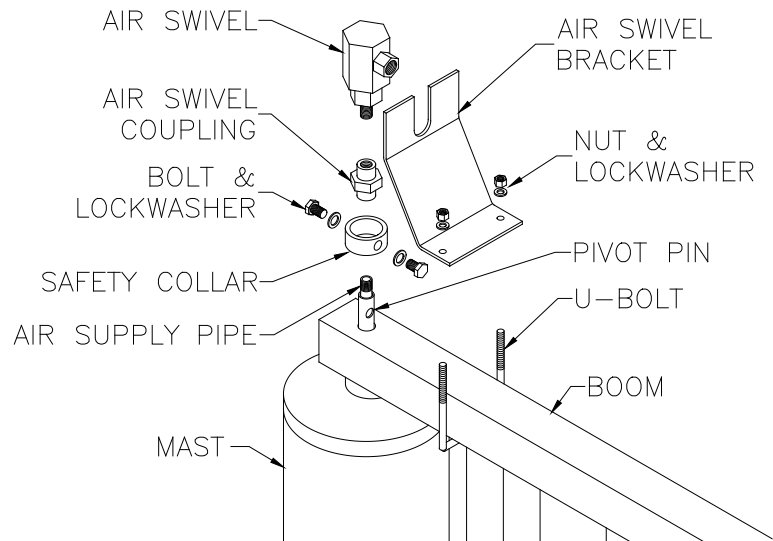
- A) Connect holder angle to boom using U-bolt and mounting hardware provided.
- B) Connect wires protruding from pivot pin to collector wires. Be sure to connect the same color wires to each other.
- C) Place collector over tip of pivot pin making sure connected wires are pushed down inside mast pipe and the collector housing outlet is captured by the holder angle.
- D) Lock collector in place by tightening set screws at base of collector.
- E) Replace cover of collector housing.
- F) Connect power source to junction box on mast.



**Diagram 9A.** *Installing electrical bottom entry collector.*

### Bottom Entry Air Swivel Assembly (*diagram 9B*)

- A) Attach safety collar to pivot pin using bolts and lockwasher.
- B) Connect air swivel bracket to boom using U-bolt and hardware provided.
- C) Connect air swivel coupling to air supply pipe protruding from pivot pin.
- D) Connect air swivel to air swivel coupling. Line up the outlet with the boom.
- E) Slide the air swivel bracket so that the slot in the top of the bracket captures the air swivel outlet. Be sure nuts are tight and lockwashers are flat.
- F) Connect air supply to inlet at base of mast.



**Diagram 9B.** *Installing bottom entry air swivel assembly.*

## STEP 9 - ACCESSORIES (OPTIONAL) (CONTINUED)

### Rotation Stops

#### WARNING

Rotation Stops are meant to limit rotation, not stop rotation.

#### For WSJ360 (diagram 9C)

- A) Swing boom to its maximum placement in one direction. Place rotation stop on top of the mast.
- B) Weld the rotation stop with face of the shock absorber flush to the horizontal portion of the boom and close to the edge of the top plate, as far as possible from the pivot shaft (per AWS D1.1 specifications, using E70xx electrodes).
- C) Repeat steps A and B for the opposite direction.

#### For WSJ200

Rotation stop is made of cast iron and is welded to steel. Follow proper welding procedures for this condition or contact Gorbel® Customer Service at 800-821-0086 for further information.

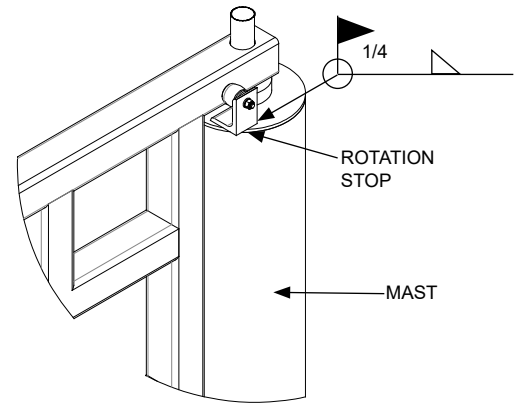


Diagram 9C. Welding rotation stops on the WSJ360.

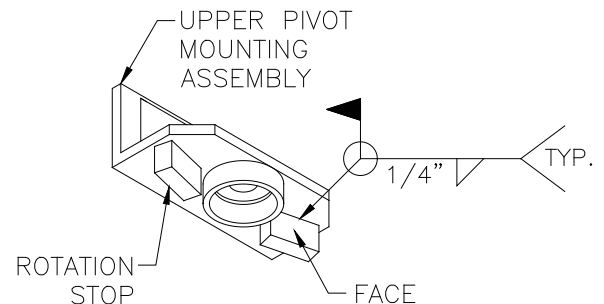


Diagram 9D. Welding rotation stops on the WSJ200.

### Other Options Available from Gorbel (Consult Gorbel® Representative)

- Electrical Top Entry Collector
- Top Entry Air Swivel
- WSJ360 Portable Base
- WSJ360 Foundationless Jibs
- Hexagonal Base Plate Templates
- Hexagonal Base Plate Anchor Bolts
- Vacuum Platform Attachment
- Festoon Trolleys
- Festoon Cable
- Festoon Gliders
- Festoon Clamp
- Air Hose (1/2" or 3/8")

## STEP 10 - FINAL STEPS

➡ **TIP:** Do not throw away this manual: maintenance schedule is on back cover.

- 10.1 Check to make sure all bolts are tight and lockwashers are compressed.
- 10.2 Once all trolleys and end stops are installed, confirm that the trolleys contact the end stops appropriately and are not at risk of rolling past the stops.
- 10.3 If necessary, touch up crane with paint provided.
- 10.4 Install yellow rubber tracdrom on open end of steel track.
- 10.5 Keep Packing List, Installation Manual, General Arrangement Drawing, and any other inserts filed together in a safe place.

# CRANE OPERATOR INSTRUCTIONS

Overhead cranes and jib cranes generally handle materials over working areas where there are personnel. Therefore, it is important for the Crane Operator to be instructed in the use of the crane and to understand the severe consequences of careless operation. It is not intended that these suggestions take precedence over existing plant safety rules and regulations or OSHA regulations. However, a thorough study of the following information should provide a better understanding of safe operation and afford a greater margin of safety for people and machinery on the plant floor. It must be recognized that these are suggestions for the Crane Operator's use. It is the responsibility of the owner to make personnel aware of all federal, state and local rules and codes, and to make certain operators are properly trained.

## Qualifications

Crane operation, to be safe and efficient, requires skill: the exercise of extreme care and good judgment, alertness and concentration, and rigid adherence to proven safety rules and practices as outlined in applicable and current ANSI and OSHA safety standards. In general practice, no person should be permitted to operate a crane:

- Who cannot speak the appropriate language or read and understand the printed instructions.
- Who is not of legal age to operate this type of equipment.
- Whose hearing or eyesight is impaired (unless suitably corrected with good depth perception).
- Who may be suffering from heart or other ailments which might interfere with the operator's safe performance.
- Unless the operator has carefully read and studied this operation manual.
- Unless the operator has been properly instructed.
- Unless the operator has demonstrated his instructions through practical operation.
- Unless the operator is familiar with hitching equipment and safe hitching equipment practices.

## Handling the Jib Boom Motion

Before using the boom of the jib crane, the operator should be sure the hook is high enough to clear any obstruction. Before a load is handled by the crane, the jib boom should be brought into position so that it is directly over the load. Start the jib boom slowly and bring it up to speed gradually. Approaching the place where it is desired to stop the jib, reduce the boom speed.

## Handling the Trolley Motion

Before a load is handled, the hoist should be positioned directly over the load that is to be handled. When the slack is taken out of the slings, if the hoist is not directly over the load, bring it directly over the load before hoisting is continued. Failure to center the hoist over the load may cause the load to swing upon lifting. Always start the trolley motion slowly and reduce the trolley speed gradually.

## Handling the Hoist Motion

Refer to the lifting (hoist) equipment's operating instructions.

# GENERAL SUGGESTIONS

## Know Your Crane

Crane operators should be familiar with the principal parts of a crane and have a thorough knowledge of crane control functions and movements. The crane operator should be required to know the location and proper operation of the main conductor disconnecting means for all power to the attachments on the crane.

## Responsibility

Each crane operator should be held directly responsible for the safe operation of the crane. Whenever there is any doubt as to SAFETY, the crane operator should stop the crane and refuse to handle loads until: (1) safety has been assured or (2) the operator has been ordered to proceed by the supervisor, who then assumes all responsibility for the SAFETY of the lift.

Do not permit **ANYONE** to ride on the hook or a load.

## Inspection

Test the crane movement and any attachments on the crane at the beginning of each shift. Whenever the operator finds anything wrong or apparently wrong, the problem should be reported immediately to the proper supervisor and appropriate corrective action taken.

## Operating Suggestions

One measure of a good crane operator is the smoothness of the crane operation. The good crane operator should know and follow these proven suggestions for safe, efficient crane handling.

1. The crane should be moved smoothly and gradually to avoid abrupt, jerky movements of the load. Slack must be removed from the sling and hoisting ropes before the load is lifted.
2. Center the crane over the load before starting the hoist to avoid swinging the load as the lift is started. Loads should not be swung by the crane to reach areas not under the crane.
3. Crane-hoisting ropes should be kept vertical. Cranes shall not be used for side pulls.
4. Be sure everyone in the immediate area is clear of the load and aware that a load is being moved.
5. Do not make lifts beyond the rated load capacity of the crane, sling chains, rope slings, etc.
6. Make certain that before moving the load, load slings, load chains, or other lifting devices are fully seated in the saddle of the hook with the hook latch closed (if equipped with hook latch).
7. Check to be sure that the load and/or bottom block is lifted high enough to clear all obstructions when moving boom or trolley.
8. At no time should a load be left suspended from the crane unless the operator has the push button with the power on, and under this condition keep the load as close as possible to the floor to minimize the possibility of an injury if the load should drop. When the crane is holding a load, the crane operator should remain at the push button.
9. Do not lift loads with sling hooks hanging loose. If all sling hooks are not needed, they should be properly stored, or use a different sling.
10. All slings or cables should be removed from the crane hooks when not in use (dangling cables or hooks hung in sling rings can inadvertently snag other objects when the crane is moving).
11. Operators shall not carry loads and/or empty bottom blocks over personnel. Particular additional caution should be practiced when using magnet or vacuum devices. Loads, or parts of loads, held magnetically could drop. Failure of power to magnets or vacuum devices can result in dropping the load. Extra precaution should be exercised when handling molten metal in the proximity of personnel.
12. Whenever the operator leaves the crane the following procedure should be followed:
  - Raise all hooks to an intermediate position.
  - Spot the crane at an approved designated location.
  - Place all controls in the "off" position.
  - Open the main switch to the "off" position.
  - Make visual check before leaving the crane.
13. In case of emergency or during inspection, repairing, cleaning or lubrication, a warning sign or signal should be displayed and the main switch should be locked in the "off" position. This should be done whether the work is being done by the crane operator or by others.
14. Contact with rotation stops or trolley end stops shall be made with extreme caution. The operator should do so with particular care for the safety of persons below the crane, and only after making certain that any persons on the other cranes are aware of what is being done.
15. ANY SAFETY FEATURES AND MECHANISMS BUILT-IN OR OTHERWISE PROVIDED WITH THE CRANE BY GORBEL ARE REQUIRED FOR THE SAFE OPERATION OF THE CRANE. DO NOT, UNDER ANY CIRCUMSTANCES, REMOVE OR OTHERWISE IMPAIR OR DISABLE THE PROPER FUNCTIONING OF ANY CRANE SAFETY MECHANISMS OR FEATURES BUILT-IN OR OTHERWISE PROVIDED BY GORBEL FOR SAFE OPERATION OF THE CRANE. ANY REMOVAL, IMPAIRMENT OR DISABLING OF ANY SUCH SAFETY MECHANISMS OR FEATURES OR OTHER USE OR OPERATION OF THE CRANE WITHOUT THE COMPLETE AND PROPER FUNCTIONING OF ANY SUCH SAFETY MECHANISMS OR FEATURES AUTOMATICALLY AND IMMEDIATELY VOIDS ANY AND ALL EXPRESS AND IMPLIED WARRANTIES OF ANY KIND OR NATURE.

## LIMITED WARRANTY

It is agreed that the equipment purchased hereunder is subject to the following LIMITED warranty and no other. Gorbel Incorporated ("Gorbel") warrants the manual push-pull Work Station Cranes, Jib Crane, and Gantry Crane products to be free from defects in material or workmanship for a period of ten years or 20,000 hours use from date of shipment. Gorbel warrants the Motorized Work Station Cranes and Jib Crane products to be free from defects in material or workmanship for a period of two years or 4,000 hours use from the date of shipment. Gorbel warrants the G-Force® and Easy Arm™ products to be free from defects in material or workmanship for a period of one year or 2,000 hours use from the date of shipment. This warranty does not cover Gantry Crane wheels. This warranty shall not cover failure or defective operation caused by operation in excess of recommended capacities, misuses, negligence or accident, and alteration or repair not authorized by Gorbel. No system shall be field modified after manufacture without the written authorization of Gorbel, Inc. Any field modification made to the system without the written authorization of Gorbel, Inc. shall void Gorbel's warranty obligation. OTHER THAN AS SET FORTH HEREIN, NO OTHER EXPRESS WARRANTIES, AND NO IMPLIED WARRANTIES, ORAL OR WRITTEN, INCLUDING BUT NOT LIMITED TO THE WARRANTIES OF MERCHANTABILITY OR FITNESS FOR PARTICULAR PURPOSE, ARE MADE BY GORBEL WITH RESPECT TO ITS PRODUCTS AND ALL SUCH WARRANTIES ARE HEREBY SPECIFICALLY DISCLAIMED. GORBEL SHALL NOT BE LIABLE UNDER ANY CIRCUMSTANCES FOR ANY INCIDENTAL, SPECIAL AND/OR CONSEQUENTIAL DAMAGES WHATSOEVER, WHETHER OR NOT FORESEEABLE, INCLUDING BUT NOT LIMITED TO DAMAGES FOR LOST PROFITS AND ALL SUCH INCIDENTAL, SPECIAL AND/OR CONSEQUENTIAL DAMAGES ARE HEREBY ALSO SPECIFICALLY DISCLAIMED. Gorbel's obligation and Purchaser's or end user's sole remedy under this warranty is limited to the replacement or repair of Gorbel's products at the factory, or at the discretion of Gorbel, at a location designated by Gorbel. Purchaser or end user shall be solely responsible for all freight and transportation costs incurred in connection with any warranty work provided by Gorbel hereunder. Gorbel will not be liable for any loss, injury or damage to persons or property, nor for damages of any kind resulting from failure or defective operation of any materials or equipment furnished hereunder. Components and accessories not manufactured by Gorbel are not included in this warranty. Purchaser's or end user's remedy for components and accessories not manufactured by Gorbel is limited to and determined by the terms and conditions of the warranty provided by the respective manufacturers of such components and accessories.

**A) DISCLAIMER OF IMPLIED WARRANTY OF MERCHANTABILITY**

Gorbel and Purchaser agree that any claim made by Purchaser which is inconsistent with Gorbel's obligations and the warranty remedies provided with Gorbel's products, and in particular, special, incidental and consequential damages, are expressly excluded.

**B) DISCLAIMER OF IMPLIED WARRANTY OF FITNESS FOR PARTICULAR PURPOSE**

Gorbel and Purchaser agree that the implied warranty of fitness for particular purpose is excluded from this transaction and shall not apply to the goods involved in this transaction.

**C) DISCLAIMER OF EXPRESS WARRANTY**

Gorbel's agents, or dealer's agents, or distributor's agents may have made oral statements about the machinery and equipment described in this transaction. Such statements do not constitute warranties, and Purchaser agrees not to rely on such statements. Purchaser also agrees that such statements are not part of this transaction.

**D) DISCLAIMER OF SPECIAL, INCIDENTAL AND CONSEQUENTIAL DAMAGES**

Gorbel and Purchaser agree that any claim made by Purchaser which is inconsistent with Gorbel's obligations and the warranty remedies provided with Gorbel's products, and in particular, special, incidental and consequential damages, are expressly excluded.

**E) DEALER OR DISTRIBUTOR NOT AN AGENT**

Gorbel and Purchaser agree that Purchaser has been put on notice that dealer or distributor is not Gorbel's agent in any respect for any reason. Gorbel and Purchaser also agree that Purchaser has been put on notice that dealer or distributor is not authorized to incur any obligations or to make any representations or warranties on Gorbel's behalf other than those specifically set forth in Gorbel's warranty provided in connection with its product.

**F) MERGER**

This warranty agreement constitutes a final and complete written expression of all the terms and conditions of this warranty and is a complete and exclusive statement of those terms.

**G) PAINTING**

Every crane (excluding components) receives a quality paint job before leaving the factory. Unfortunately, no paint will protect against the abuses received during the transportation process via common carrier. We have included at least one (1) twelve ounce spray can for touchup with each crane ordered (unless special paint was specified). If additional paint is required, contact a Gorbel® Customer Service Representative at 1-800-821-0086 or 1-585-924-6262.

**Title and Ownership:**

Title to the machinery and equipment described in the foregoing proposal shall remain with Gorbel and shall not pass to the Purchaser until the full amount herein agreed to be paid has been fully paid in cash.

**Claims and Damages:**

Unless expressly stated in writing, goods and equipment shall be at Purchaser's risk on and after Seller's delivery in good shipping order to the Carrier. Gorbel shall in no event be held responsible for materials furnished or work performed by any person other than it or its authorized representative or agent.

**Cancellations:**

If it becomes necessary for the purchaser to cancel this order wholly or in part, he shall at once so advise Gorbel in writing. Upon receipt of such written notice all work will stop immediately. If the order entails only stock items, a flat restocking charge of 15% of the purchase price will become due and payable by Purchaser to Gorbel. Items purchased specifically for the canceled order shall be charged for in accordance with the cancellation charges of our supplier plus 15% for handling in our factory. The cost of material and/or labor expended in general fabrication for the order shall be charged for on the basis of total costs to Gorbel up to the time of cancellation plus 15%.

**Returns:**

No equipment, materials or parts may be returned to Gorbel without express permission in writing to do so.

Extra Charge Delay: If Purchaser delays or interrupts progress of Seller's performance, or causes changes to be made, Purchaser agrees to reimburse Gorbel for expense, if any, incident to such delay.

**Changes and Alterations:**

Gorbel reserves the right to make changes in the details of construction of the equipment, as in its judgment, will be in the interest of the Purchaser; will make any changes in or additions to the equipment which may be agreed upon in writing by the Purchaser; and Gorbel is not obligated to make such changes in products previously sold any customer.

**Third Party Action:**

Should Gorbel have to resort to third party action to collect any amount due after thirty (30) days from date of invoice, the Purchaser agrees to pay collection costs, reasonable attorney's fees, court costs and legal interest.

**OSHA Responsibilities:**

Gorbel agrees to fully cooperate with Purchaser in the design, manufacture or procurement of safety features or devices that comply with OSHA regulations. In the event additional equipment or labor shall be furnished by Gorbel, it will be at prices and standard rates then in effect, or as may be mutually agreed upon at the time of the additional installation.

**Equal Employment Opportunity:**

Gorbel agrees to take affirmative action to ensure equal employment opportunity for all job applicants and employees without regard to race, color, age, religion, sex, national origin, handicap, veteran, or marital status. Gorbel agrees to maintain non-segregated work facilities and comply with rules and regulations of the Secretary of Labor or as otherwise provided by law or Executive Order.

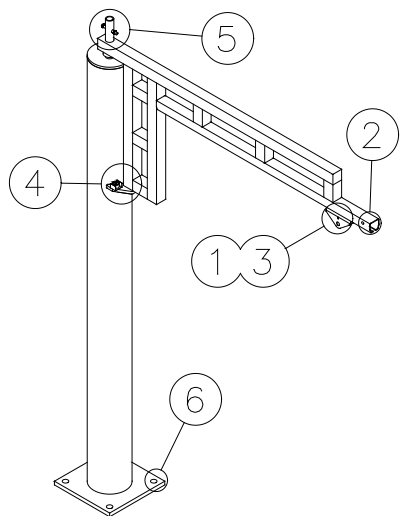
# INSPECTION AND MAINTENANCE SCHEDULE

GORBEL® WORK STATION JIB CRANE INSPECTION AND MAINTENANCE SCHEDULE			
ITEM	COMPONENT	MAINTENANCE	FREQUENCY*
1	Hoist Trolley	Check clevis pin for wear. Cotter pin should be fully wrapped around clevis. Replace cotter pin if cracked or fatigued.	Every 2000 hours or yearly
2	End Stop	Check for full compression of lockwasher.	Every 2000 hours or yearly
3	Wheels	Check for cracks, pits, and/or grooves. All of these increase pull forces. If any of these conditions exist, wheels should be replaced.	Every 2000 hours or yearly
4	Trunnion Rollers or Cam Followers	Check to make sure both rollers have full face contact with pipe and lockwashers are compressed. Check to see that cam guard is installed.	Every 1000 hours or 6 months
5	Pivot Pin(s)	Check that cotter pin or retaining pin and O-rings are properly installed so that boom cannot dislodge.	Every 2000 hours or yearly
6	Mounting Bolts or Anchor Bolts	Check that lockwashers are compressed and nuts tightened to manufacturer's specifications. If Gorbelt is the supplier of the anchor bolts, tighten to full compression of the lockwasher.	Every 500 hours or 3 months
7	Accessory Items	Conduct a general inspection of all accessory items.	Every 1000 hours or 6 months
8	Gorbelt® Crane	Conduct a visual inspection of the crane overall.	Every 1000 hours or 6 months

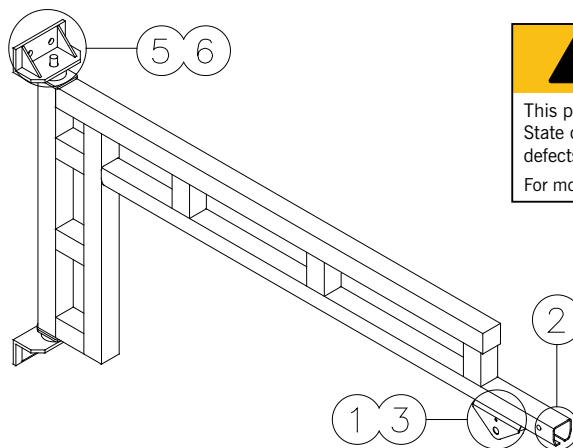
\*Federal, state and local codes may require inspection and maintenance checks more often. Please check the federal, state and local code manuals in your area.

## WARNING

Any changes in rolling effort or unusual noises must be immediately identified and corrected. It is not necessary to lubricate the track or bearings. Lubricating may attract airborne particles and may increase the rolling resistance. **Do not use such substances as WD40®, silicone sprays, oil or grease.**



**WSJ360**  
Free Standing Crane



**WSJ200**  
Wall/Column Mounted Crane

**⚠ WARNING**

This product contains chemicals known to the State of California to cause cancer and birth defects or other reproductive harm.

For more information: [www.P65Warnings.ca.gov](http://www.P65Warnings.ca.gov)

600 Fishers Run, P.O. Box 593  
Fishers, NY 14453-0593  
Phone: (800) 821-0086  
Fax: (800) 828-1808  
E-Mail: [info@gorbel.com](mailto:info@gorbel.com)  
<http://www.gorbel.com>  
© 2026 Gorbelt Inc.  
All Rights Reserved

