

GORBEL[®]
A CLASS ABOVE

www.gorbel.com



CRANES

**FREE STANDING
WORK STATION BRIDGE CRANES**

CAPACITIES: Up to 4000 lbs

SPANS: Up to 30'

ENCLOSED TRACKS: Steel, Aluminum & Stainless Steel

PRODUCTIVITY: Average 28% Increase



CORBEL 4000
MADE IN THE U.S.A. 3107 STEEL CAPACITY

DANGER

WARNING
BE AWARE OF THE POSITION OF THE LOAD AT ALL TIMES.

CAUTION
DO NOT
FOR LIFT

A Class Above...

- In Productivity.*
- In Safety.*
- In Ease of Positioning and Movement.*
- In Ease of Installation.*
- In Designs, Capacities, and Spans.*

It's no wonder more and more businesses like yours are choosing Gorbel. As an innovator and leader in the enclosed track work station crane industry, Gorbel provides a wide variety of overhead solutions. Our work station systems include free standing work station bridge cranes (covered in this brochure), ceiling mounted bridge cranes and monorails, and work station jib cranes. And we're also a leading manufacturer of high-performance manual and motorized jib cranes. All this, plus quick delivery and the industry's best warranty.



TABLE OF CONTENTS

General Information

How to apply	2
Enclosed track design	3
Rigid runways	4
Mixed-capacity systems	4
Multiple Bridge Options	5
Anatomy of a crane	6 - 9
Installation Guidelines	10

Bridge Crane Drawings

Steel bridge crane	isometric	11
Aluminum bridge crane	isometric	12
Steel bridge crane	multi-view	13
Aluminum bridge crane	multi-view	14

Bridge Crane Systems & Dimensional Charts

250 lb. capacity bridge cranes	15 - 17
500 lb. capacity bridge cranes	18 - 20
1000 lb. capacity bridge cranes	21 - 23
2000 lb. capacity bridge cranes	24 - 26
4000 lb. capacity bridge cranes	27 - 29

How to Apply Ergonomic Overhead Work Station Cranes

These questions and answers can help you determine which type of overhead work station crane best meets your needs.

What Type of Crane Is Most Appropriate?

- Bridge cranes cover rectangular areas, while jib cranes cover circular areas.
- Bridge cranes can be floor supported (see this brochure) or hung from the ceiling (see the *Gorbel® Ceiling Mounted Bridge Crane & Monorail* brochure). Jib cranes can be wall or pillar mounted and may require a special foundation (see the *Gorbel® Work Station Jib Crane* brochure).
- An enclosed track work station bridge crane provides consistent ease of operation over the full range of movement.
- Jib cranes move more easily at the very end of the boom and are more difficult to move as the load approaches the pivot point.

Should the crane be manual or motorized?

Ease of movement and low weight are key features of enclosed track work station crane systems. In fact, manual work station cranes do the job faster than motorized cranes. If the operator cannot control the load throughout the operation (for instance, over a vat, pit, or other inaccessible area), then the crane should be motorized.

What type of suspension: free standing or ceiling mounted?

- Free standing (floor-supported) systems do not put stress on the building's overhead structure. Installation is usually more straightforward, and these cranes are also easier to relocate in the future. These systems require a reinforced concrete floor of at least 6 inches.
- With ceiling mounted systems, supporting steel does not interfere with the handling operation. Ceiling mounted systems require a building with an adequate overhead structure to hang the crane.

What capacity, bridge length, and height?

The general rule is "less is more"

- *Keep capacities to a minimum.* Gorbel® Work Station Cranes are designed with an adequate safety factor. If you "over-buy capacity," the operator will need to move extra bridge dead weight, which would not be a good ergonomic solution.
- *Keep bridge lengths to a minimum.* The less dead weight an operator has to move, the better. Short bridge lengths are better for higher-cycle production areas. Longer bridges are acceptable for lower-production cycle or maintenance areas.
- *Keep bridge heights (trolley saddle) to a minimum.* Keeping the trolley saddle (TS) height less than 14 feet is desirable because it makes it easier to control and position the load.

Can the operator safely move the load?

- A work cell should be designed so a task can be performed by 90% of the workers.
- A worker should not exceed 33% of his or her capacity; otherwise, the risk of chronic fatigue increases.
- To help determine if your worker can safely move the required loads, refer to *Ergonomic Study* by Shealy and Stibitz ©1993, which is available through your Gorbel Dealer.

Enclosed Track Design Makes for Easy Movement and Long Life

Both the aluminum and steel Gorbels® Work Station Crane Systems utilize enclosed track that is high in strength and low in weight. Major advantages:

- Enclosed track cranes are up to three times easier to move than traditional bridge cranes.
- The design virtually eliminates dirt and dust from the rolling surface, thus reducing wear on the wheels of the trolley and end trucks.
- The smooth running surface means lower rolling resistance.
- The low profile of the steel track allows the system to be installed where headroom is a problem.
- The low track weight reduces the applied forces exerted on the supporting structure.
- Long spans allow systems to be installed where support assemblies are infrequent (up to 30 feet with steel truss design). This reduces the possibility of the support columns interfering with the work cell layout.
- Four distinct sizes of track -- 250, 500, 1000, and 2000 series -- enable you to keep bridge weights and costs to a minimum.

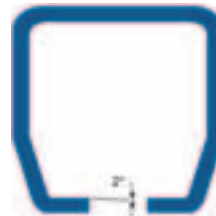

The 2° taper of the running flange helps to center the trolley in the track for smooth, effortless movement of trolleys and end trucks.

TRUSSED STEEL TRACK:

Permits longer spans which allows more flexibility in crane layout.

The trussed series uses the plain steel track profile but is enhanced for longer spans via a built-up truss design. This design increases the span, which decreases the frequency of hangers. Model numbers start with: GLCS-FS for spans up to 20 feet, GLCSL-FS for spans up to 25 feet, and GLCSLX-FS for spans up to 30 feet.

Long spans translate into fewer runway support points, less interference of work cell layout, longer bridge lengths, and free standing capabilities... just another reason why Gorbels® Work Station Cranes are among the most versatile to apply and easiest to install in the industry.

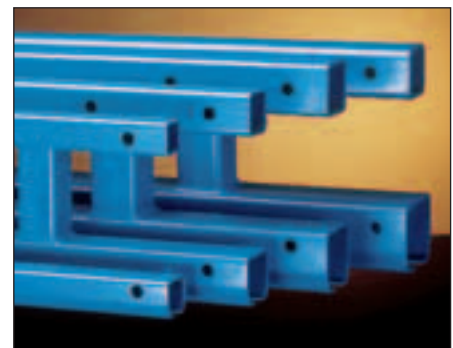

Trussed Steel Track

ALUMINUM TRACK:

For use where lower bridge weight and easier movement are required.

The patented shape of Gorbels' aluminum enclosed track provides for low weight, unparalleled spanning capability, and effortless movement. The low weight (up to 44% less than trussed steel track) results in easier movement, which makes for safe, productive, ergonomic work cells. Runway spans up to 20 feet and bridge lengths up to 34 feet meet a wide range of applications. Model numbers start with AL-FS.



Aluminum Track

Rigid Runways Provide for Superior Positioning of Loads

Gorbel® Work Station Bridge Cranes are installed so that the runways are rigid. They do not move laterally or longitudinally. In addition, Gorbel's floating end trucks with horizontal wheels prevent binding. The combination of these design features results in unmatched ease of positioning and ease of movement. The bridge travels smoothly down the runways, and movement is unvarying along the way, no matter where a load is positioned on the bridge. This allows superior load positioning.

Another advantage of rigid runways is that runways double as stringers between support columns. This eliminates the need for expensive intermediate support stringers, and it lowers overall installation cost.

Mixed Capacity Bridge Crane Systems:

Reduced bridge dead weight equals better ergonomic solutions.

Mixed-capacity systems allow multiple lower capacity bridges to be used on higher capacity runways, provided the equivalent center loads (ECL) are verified at the factory to ensure that runways and hangers are not overloaded. For example, using Gorbel's mixed-capacity end trucks, four 500 lb. bridges (utilizing 500 series rail) can be hung from a 2000 lb. runway, allowing side-by-side use of *all four bridges* without overloading the system. By mixing bridges of various sizes and capacities, mixed-capacity systems offer reduced bridge dead weight, easier movement, and reduced cost.

Easy to Install

Gorbel® Free Standing Work Station Bridge Cranes can be installed on any normal 6" reinforced concrete floor. Each column is anchored by four bolts, thus eliminating the need for field welding.

Support columns are designed to AISC specifications. If no movement of the support assemblies is required, then bracing to the building is recommended (not included).

Modular Design

The pre-engineered modular kit design permits easy expansion or relocation. The runway length can be increased by adding runway sections, free standing support assemblies and additional bridges as needed.

What is meant by Rated Capacity?

The rated capacity is the live load that can be lifted by the crane system. The design load for the crane system is based on the rated capacity plus 15% for the weight of the hoist and trolley (capacity \times 1.15) and an additional 25% for impact (capacity \times 1.25) for a total design of capacity \times 1.4 (Note, 25% impact factor is good for hoist speeds up to 50 f.p.m.). For example, a 1000 lb. Gorbel® crane allows you to pick up a 1000 lb. load, provided the hoist weighs 150 lb. or less and the hoist speed is less than 50 feet per minute.

Design load for deflection calculations is based on the rated capacity plus 15% for the weight of the hoist and trolley (capacity \times 1.15). *Under no conditions should the crane be loaded beyond its rated capacity.* Gorbel® Work Station Cranes meet or exceed the ANSI B30.11 specifications for underhung bridge cranes.



Gorbel® crane designs have been audited by an independent third party Professional Engineer and meet or exceed the requirements to be MMA Certified in accordance with the terms of the Material Handling Industry of America.

WARNING: Equipment described in this brochure is not designed for, and should not be used for, lifting, supporting, or transporting humans. Failure to comply with any one of the limitations noted can result in serious bodily injury and/or property damage.



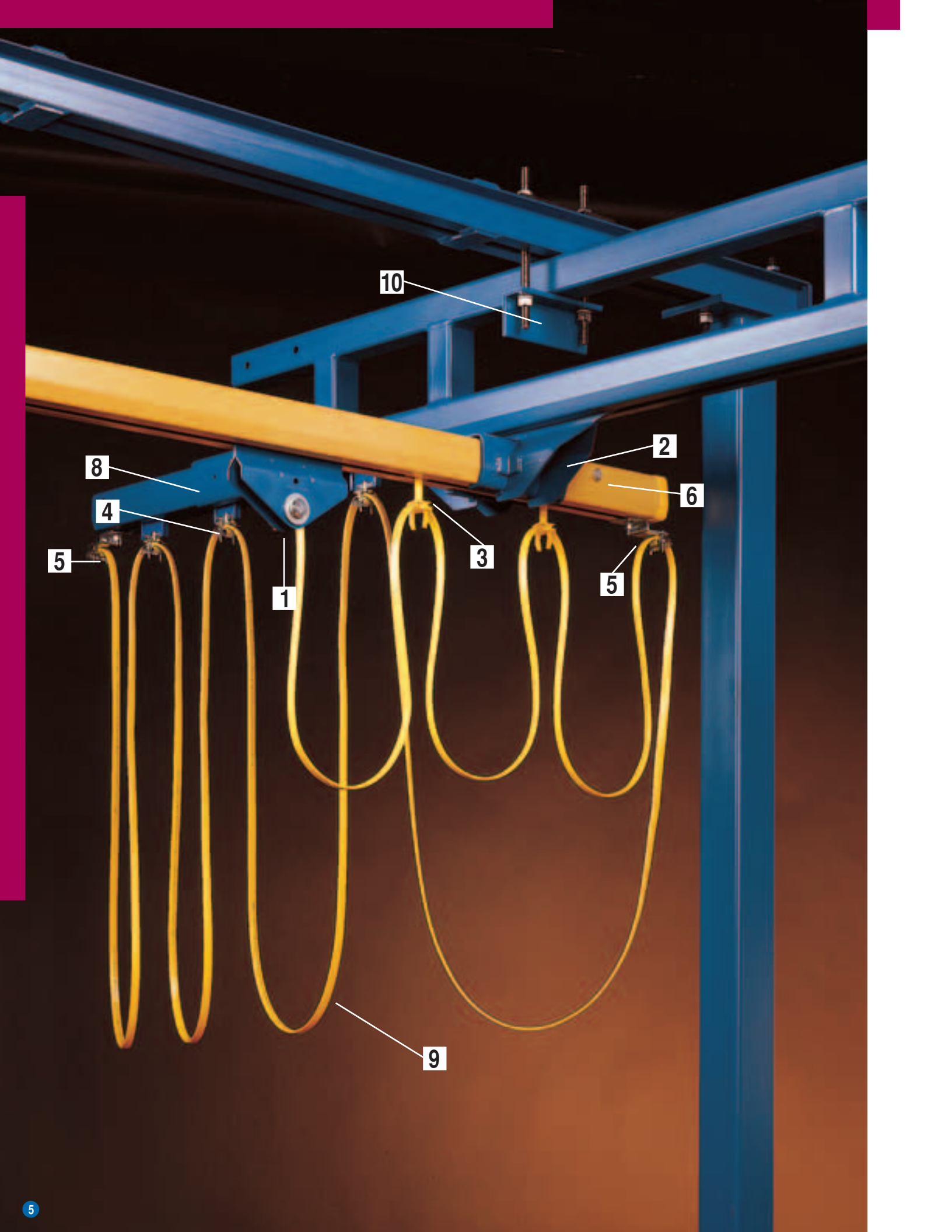

10

2

6

8

4

5

1

3

5

9

Anatomy of a Work Station Crane

1 HOIST TROLLEYS

Gorbel's hoist trolleys provide the connection between the lifting device and the bridge. The trolleys are designed for effortless movement along the bridge. The stamped body fits most rigid hook or eye lifting devices.

- Wheels are tapered to match the 2° taper of the track. This reduces rolling resistance and wheel wear. Wheels contain ball bearings that are sealed and lubricated for life.
- Trolleys are designed to operate in temperatures from +5°F to +200°F.
- All trolleys meet or exceed the ANSI B30.11 specification for underhung bridge cranes.



2 END TRUCKS

Gorbel® end trucks provide the connection between the bridge and runways. They are designed for effortless movement along the runway.

- Wheels are tapered to match the 2° taper of the track, which reduces rolling resistance and wheel wear. Wheels contain ball bearings that are sealed and lubricated for life.
- Two horizontal wheels center the end truck within the runway which prevents binding of the bridge. As a result, the position of the load on the bridge has little effect on the amount of force needed to move the bridge along the runway.
- Any slight runway track misalignment is taken up by the bridge floating in one end truck, while the other end truck is firmly clamped to the bridge.
- All end trucks meet or exceed the ANSI B30.11 specification for underhung bridge cranes.

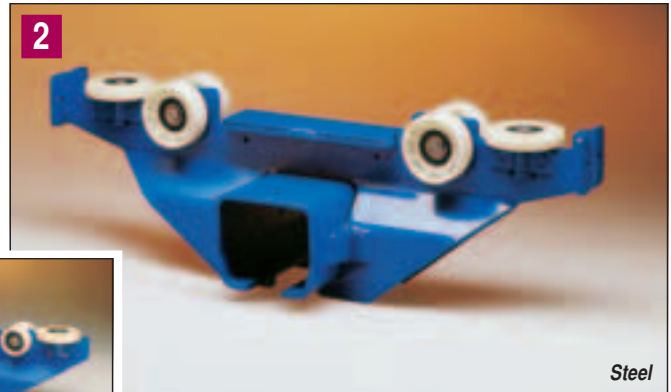

3 FESTOON GLIDERS

Festoon gliders are used to support flat cable along the runway and bridge, and they are standard on steel runways of 63 feet or less. No tools are required to attach the festooning to the gliders.



4 FESTOON TROLLEYS

Gorbel® festoon trolleys (optional) are used to support flat cable or air hose along the runway or bridge. The trolleys have four wheels and a pivoting festoon saddle support. They are ideally suited for long runways (greater than 63 feet) or with round cable or air hose. With runways greater than 63 feet or with an all aluminum system, festoon trolleys are standard. Special festoon trolleys for vacuum hose are also available.

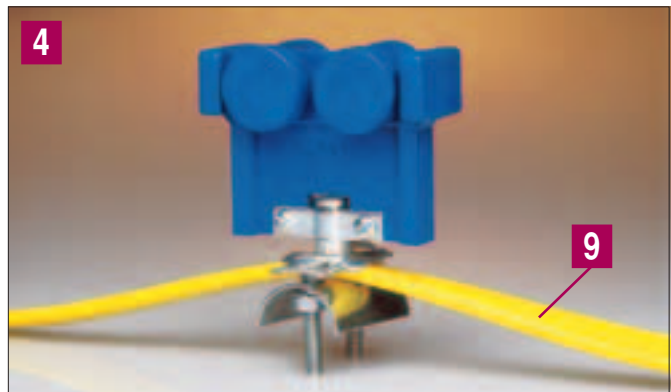

5 FESTOON CLAMPS

Festoon clamps anchor the festooning at the start of the runway and bridge. They also prevent the festoon gliders from exiting the track and they can provide a redundant stop for the end trucks and trolley. Festoon tow clamps are also available for systems with standard end trucks.



6 END STOP BUMPERS

High-impact molded end stop bumpers are provided on all runways and bridges to prevent the end trucks and trolley from exiting the track. The bumpers are bolted to the track to physically limit the travel of the end truck and trolley.



7 UNIVERSAL BUMPERS (not shown on pg. 5)

A universal bumper can be used as an intermediate end stop, primarily for zoning purposes.



8 STACK SECTIONS

A stack section at one end of a runway serves as an extension that allows festoon carriers to be stored on the end of the runway without reducing crane coverage.



9 FLAT CABLE AND/OR AIR HOSE

A flat cable festooning system is included in all Gorbel® Work Station Bridge Cranes. Plenty of cable is provided for 3 foot loops on the runway and 1 foot 6 inch loops on the bridge.

Optional air hose is also available and is supported by optional festoon trolleys. Gorbel® Work Station Cranes can utilize optional conductor bar electrification, but this results in an increase up to 40% of the amount of effort required to move

10 HANGER ASSEMBLIES

Each Gorbel® Work Station Bridge Crane is provided with the appropriate number of hanger assemblies, based on the number of support assemblies shown in this brochure's dimensional pages.

Hangers for Trussed Steel Track

Hangers for steel runways are included with each assembly as shown. The runways are flush mounted under the free standing support assemblies via spine clamp angles, B7 alloy threaded rods, and the appropriate hardware.



Hangers for Trussed Steel Track

Hangers for Aluminum Track

Standard hangers for aluminum runways are included with each assembly shown. The runways are flush mounted under the free standing support assemblies via beam clips, B7 alloy threaded rods, and the appropriate hardware.



Hangers for Aluminum Track

SPLICE JOINTS FOR STEEL TRACK

A splice joint is used to join track sections together and enable the installer to quickly and properly align the joined sections of track. Adjusting bolts are provided on the splice joint for leveling and aligning.

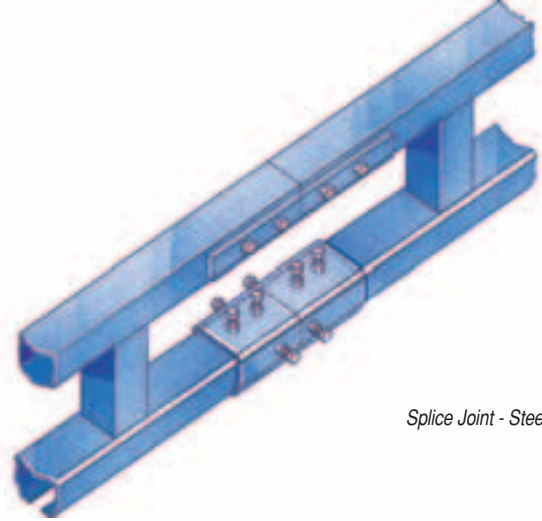

Splice Joint - Steel Track

SPLICE JOINTS FOR ALUMINUM TRACK

Patented splice joints for aluminum track allow for precise alignment. The aluminum track is extruded with four patented alignment slots. Four precision-ground pins are provided to accurately align runway sections, which provides for a smoother transition of wheels over the splice joint than is possible with bolted connections. In addition, clamp fasteners attach to the vertical web of the track to pull the track together and keep it from separating.

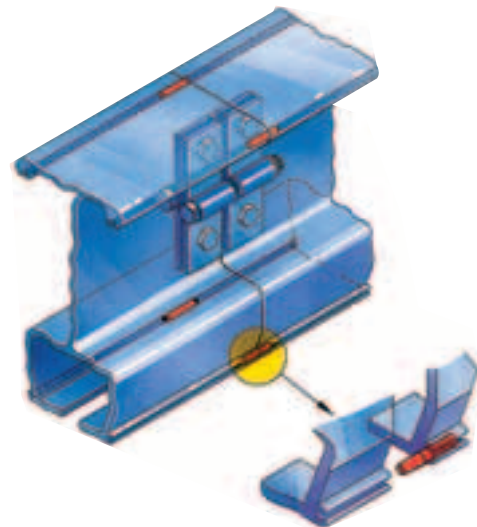

Splice Joint - AluminumTrack

INSTALLATION GUIDELINES

CAPACITY	SERIES	WEIGHT PER FOOT	MAX. L1	MAX. L2	MAX. L5	MAX. L9
250#	GLCS	4.92 #	20'	48"	18"	48"
	AL	4.05 #	20'	30"	48"	48"
	GLCSL	8.43 #	25'	48"	18"	48"
500#	GLCS	7.44 #	20'	48"	24"	48"
	AL	4.87 #	20'	30"	48"	48"
	GLCSL	10.71 #	25'	48"	24"	48"
1000#	GLCSLX	11.01 #	30'	48"	24"	48"
	GLCS	12.25 #	20'	48"	24"	48"
	AL	8.36 #	20'	30"	48"	48"
2000#	GLCSL	14.08 #	25'	48"	24"	48"
	GLCSLX	17.47 #	30'	48"	24"	48"
	GLCS	16.89 #	20'	48"	24"	48"
4000#	AL	10.01 #	20'	30"	48"	48"
	GLCSL	19.36 #	25'	48"	24"	48"
	GLCSLX	20.13 #	30'	48"	24"	48"
4000#	GLCS	20.68 #	20'	48"	24"	48"
	GLCSL	26.21 #	25'	48"	24"	48"
	GLCSLX	28.22 #	30'	48"	24"	48"

L 1 = MAXIMUM SUPPORT ASSEMBLY CENTERLINE

Maximum Support Assembly Centerline is considered from the center of a support assembly to the center of the neighboring support assembly.

L 2 = SPLICE JOINT CENTERLINE TO SUPPORT ASSEMBLY CENTERLINE

Splice Joint Centerline to Support Assembly Centerline is considered from center of a splice joint to the center of the nearest support assembly.

L 4 = BRIDGE SPAN

Bridge Span is considered from centerline to centerline of runways.
L4 = Bridge Overall Length — (2 X Bridge Cantilever)

L 5 = BRIDGE CANTILEVER

Bridge Cantilever is considered from the centerline of the runway to the end of the bridge (see table and notes).

L 9 = MAXIMUM RUNWAY CANTILEVER

Runway Cantilever is considered from the center of the end support assembly to the end of the runway.

Note: Depending on track series anti-kick-up end trucks may be required for the following:

- bridges with $\leq 8'$ span (L4) and a bridge cantilever (L5) $\geq 12'$
- bridges with $< 10'$ span (L4) and a bridge cantilever (L5) $> 15'$
- bridges with $< 15'$ span (L4) and a bridge cantilever (L5) $> 18'$

*Anti-kick-up end trucks are not included as part of the standard crane kits.

Consult Gorbel® factory for information on bridges greater than 15' span (L4).

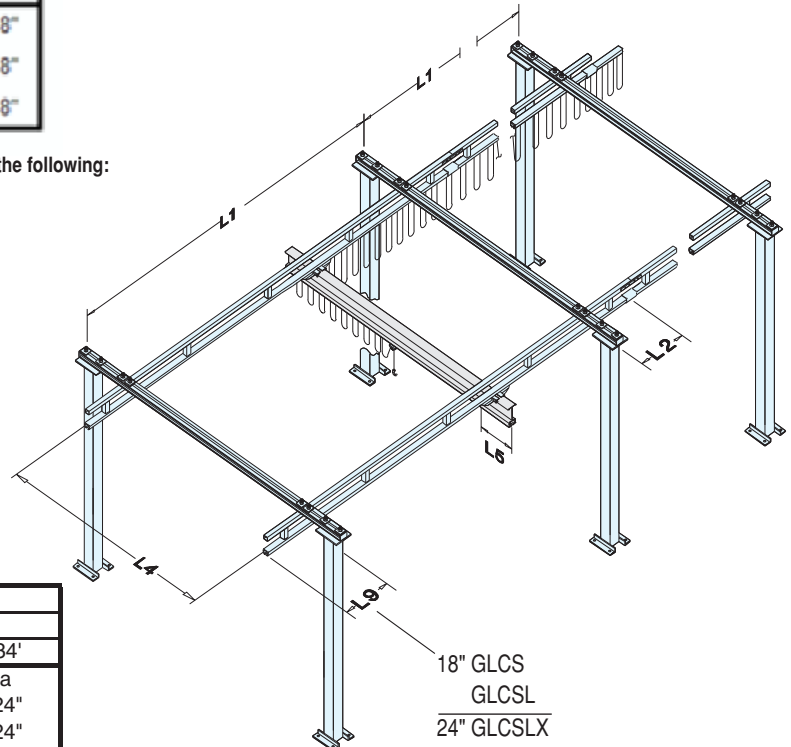

STANDARD BRIDGE CANTILEVER	Bridge Series	Bridge Overall Length				
		Steel				
		$\leq 23'$	28'	29'	33'	34'
250	12"	18"	na	na	na	
500	12"	18"	24"	18"	24"	
1000	12"	18"	24"	18"	24"	
2000	12"	18"	24"	18"	24"	
4000	15"	18"	24"	18"	24"	

STANDARD BRIDGE CANTILEVER	Bridge Series	Bridge Overall Length				
		Aluminum				
		$\leq 20'$	23'	28'	29'	33'
250	12"	18"	18"	na	na	na
500	12"	18"	18"	24"	18"	24"
1000	12"	18"	18"	24"	18"	24"
2000	12"	18"	18"	24"	18"	24"
4000	12"	18"	18"	24"	18"	24"

Note: For Bridge OALs between lengths shown, round up to the larger lengths. Maximum L5 may not be achievable (dependent on truss design of bridge). The maximum L5 dimension using AL series rail does not pertain to coped aluminum bridges.

**FREE STANDING WORK STATION BRIDGE CRANES
STEEL RUNWAYS WITH STEEL OR ALUMINUM BRIDGE
ISOMETRIC VIEW**

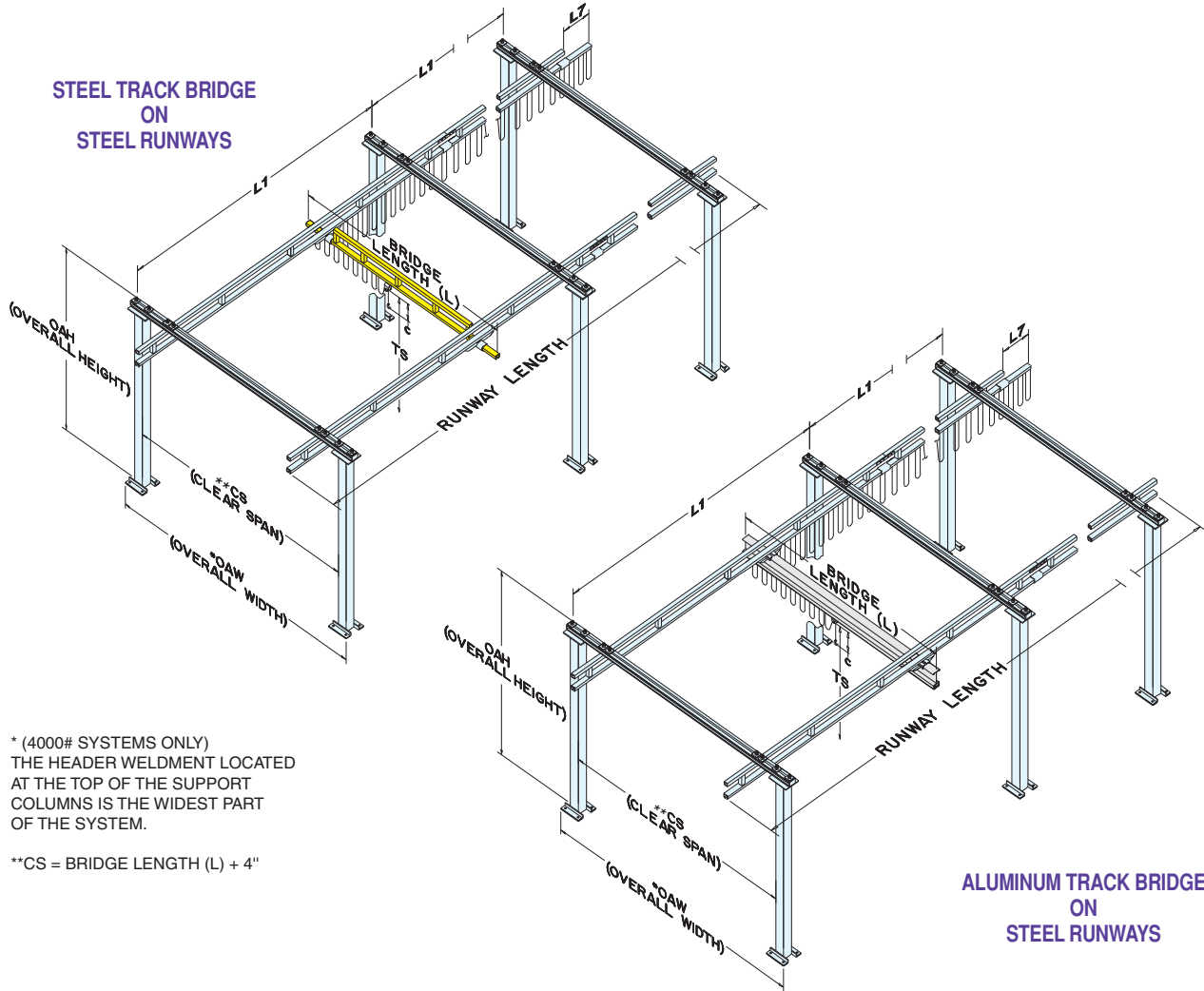

* (4000# SYSTEMS ONLY)
THE HEADER WELDMENT LOCATED
AT THE TOP OF THE SUPPORT
COLUMNS IS THE WIDEST PART
OF THE SYSTEM.

**CS = BRIDGE LENGTH (L) + 4"

**ALUMINUM TRACK BRIDGE
ON
STEEL RUNWAYS**

Model Number: _____

Capacity: _____ Pounds

Bridge Length (L): _____ (OAL)

Runway Length: _____ (OAL)

Trolley Saddle Height: _____ (TS)

L1: _____ Are the number of support assemblies
provided sufficient?

(See "SUPPORT" column on dimensional chart pages.)

C: _____ inches (hoist by others)

COLUMN BASE DETAIL
3" COLUMNS

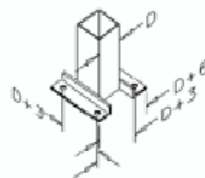

COLUMN BASE DETAIL
4" & 5" COLUMNS

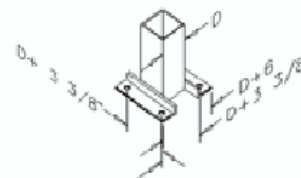

COLUMN BASE DETAIL
6" & 7" COLUMNS

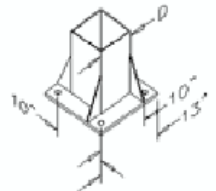

Gorbel® Free Standing Work Station Crane kits include: bridge, runways, the appropriate number of support assemblies, hoist trolley, end trucks, end stops, flat wire festooning, festoon gliders (festoon trolleys on steel runway lengths greater than 63' and all aluminum systems), festoon stack-up section, splice joints and hanger brackets. Hoist and anchor bolts provided by others.

Dimensions are for reference only and are subject to change without notice.

**FREE STANDING WORK STATION BRIDGE CRANES
ALUMINUM RUNWAYS WITH ALUMINUM BRIDGE
ISOMETRIC VIEW**

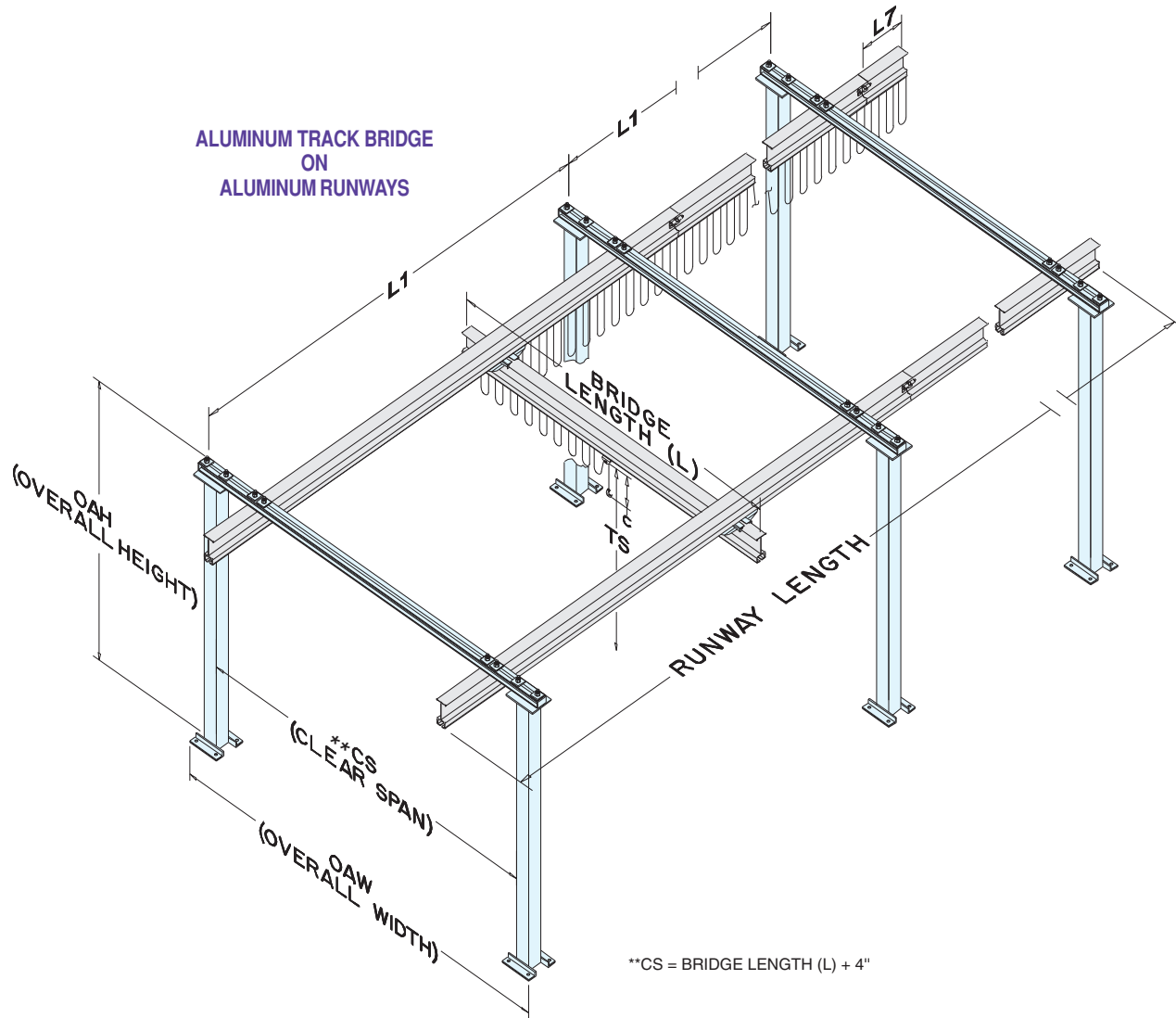

COLUMN BASE DETAIL
3" COLUMNS

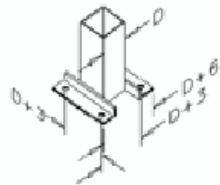

COLUMN BASE DETAIL
4" & 5" COLUMNS

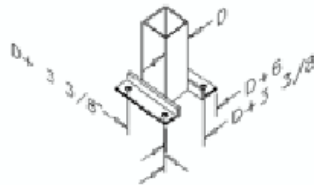

Gorbel® Free Standing Work Station Crane kits include: bridge, runways, the appropriate number of support assemblies, hoist trolley, end trucks, end stops, flat wire festooning, festoon gliders (festoon trolleys on steel runway lengths greater than 63' and all aluminum systems), festoon stack-up section, splice joints and hanger brackets. Hoist and anchor bolts provided by others.

Dimensions are for reference only and are subject to change without notice.

Model Number: _____

Capacity: _____ Pounds

Bridge Length (L): _____ (OAL)

Runway Length: _____ (OAL)

Trolley Saddle Height: _____ (TS)

L1: _____ Are the number of support assemblies provided sufficient?

(See "SUPPORT" column on dimensional chart pages.)

C: _____ inches (hoist by others)

**FREE STANDING WORK STATION BRIDGE CRANES
STEEL RUNWAYS WITH STEEL OR ALUMINUM BRIDGE**

Model Number: _____

Capacity: _____ Pounds

Bridge Length (L): _____ (OAL)

Runway Length: _____ (OAL)

Trolley Saddle Height: _____ (TS)

L1: _____ Are the number of support assemblies provided sufficient?
(See "SUPPORT" column on dimensional chart pages.)

C: _____ inches (hoist by others)

Gorbel® Free Standing Work Station Crane kits include: bridge, runways, the appropriate number of support assemblies, hoist trolley, end trucks, end stops, flat wire festooning, festoon gliders (festoon trolleys on steel runway lengths greater than 63' and all aluminum systems), festoon stack-up section, splice joints and hanger brackets. Hoist and anchor bolts provided by others. Dimensions are for reference only and are subject to change without notice.

**For L4 and L5 dimensions, refer to page 9.

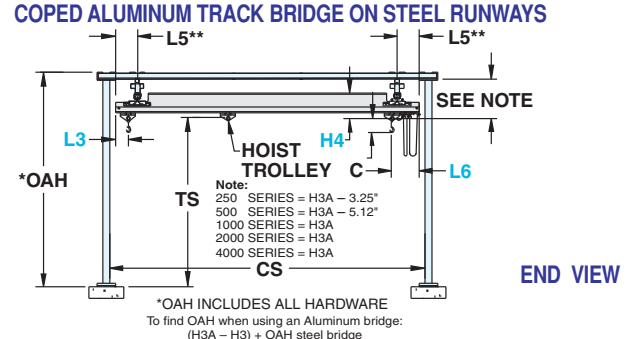
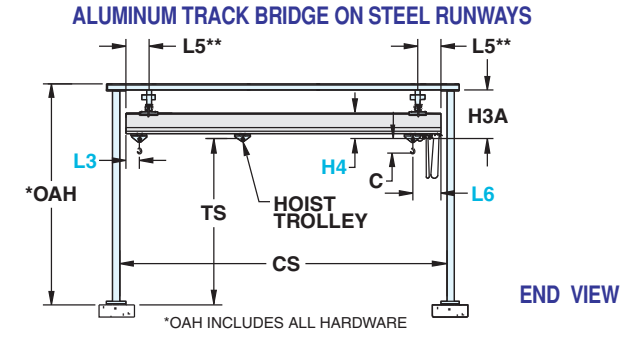
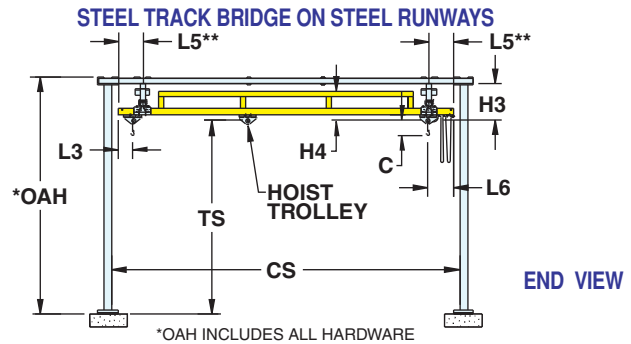

BASE BOLT PATTERN FOR 5" COLUMNS OR SMALLER

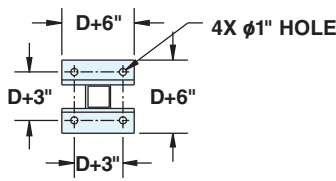

BASE BOLT PATTERN FOR 6" & 7" COLUMNS

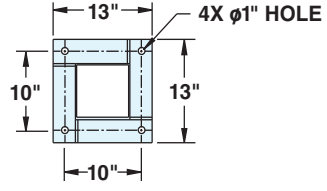

BASE BOLT PATTERN FOR 3" COLUMNS

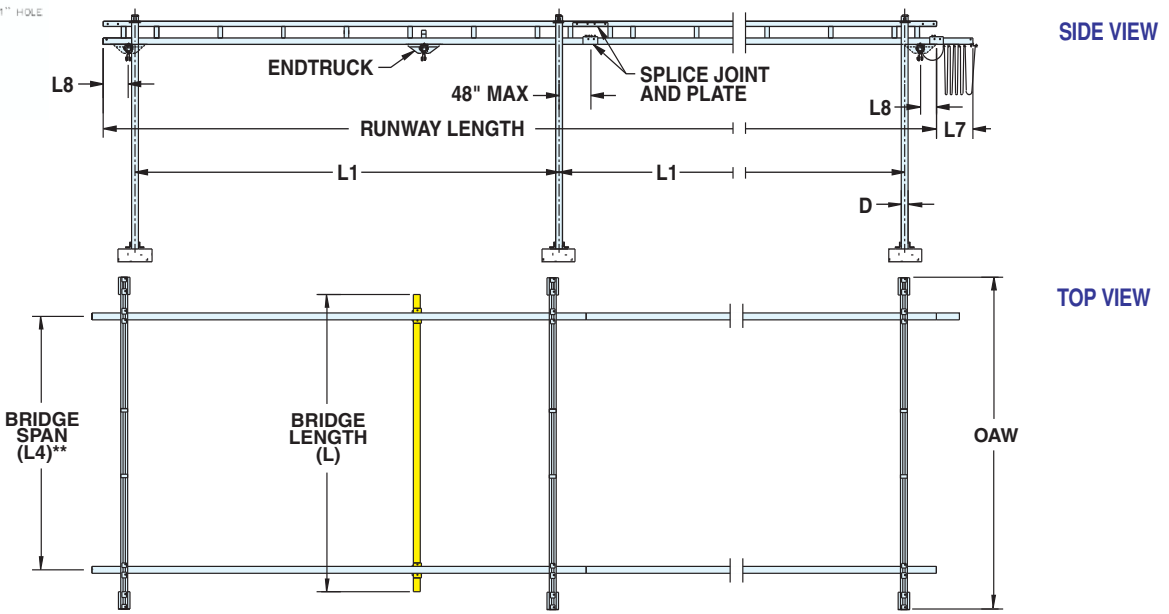
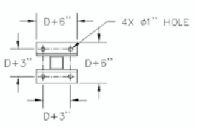

**FREE STANDING WORK STATION BRIDGE CRANES
ALUMINUM BRIDGE ON ALUMINUM RUNWAYS**

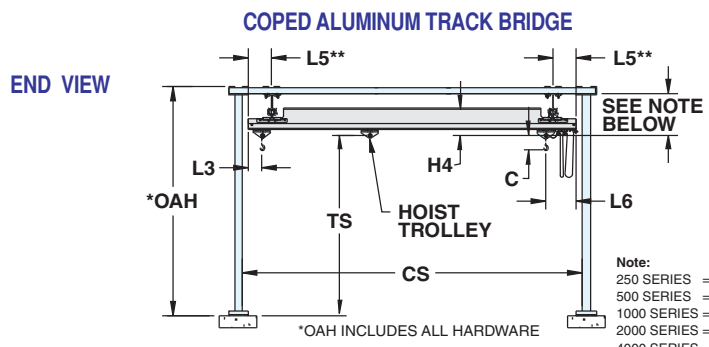
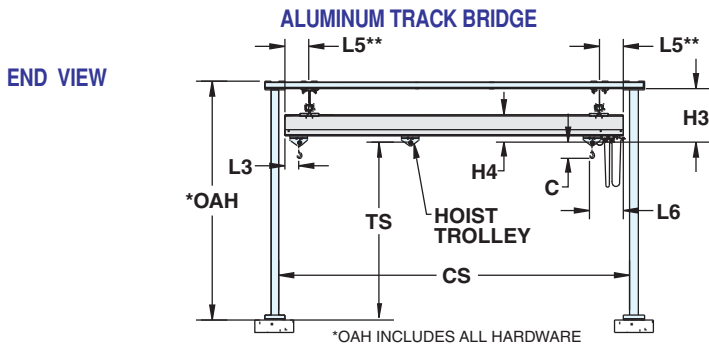

Model Number: _____

Capacity: _____ Pounds

Bridge Length (L): _____ (OAL)

Runway Length: _____ (OAL)

Trolley Saddle Height: _____ (TS)

L1: _____ Are the number of support assemblies provided sufficient?
(See "SUPPORT" column on dimensional chart pages.)

C: _____ inches (hoist by others)

Gorbel® Free Standing Work Station Crane kits include: bridge, runways, the appropriate number of support assemblies, hoist trolley, end trucks, end stops, flat wire festooning, festoon gliders (festoon trolleys on steel runway lengths greater than 63' and all aluminum systems), festoon stack-up section, splice joints and hanger brackets. Hoist and anchor bolts provided by others. Dimensions are for reference only and are subject to change without notice. **For L4 and L5 dimensions, refer to page 9.

BASE BOLT PATTERN FOR 3" COLUMNS

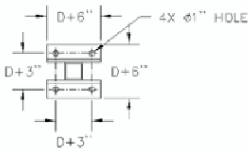

BASE BOLT PATTERN FOR 4" & 5" COLUMNS

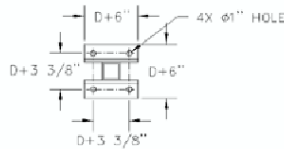

SIDE VIEW

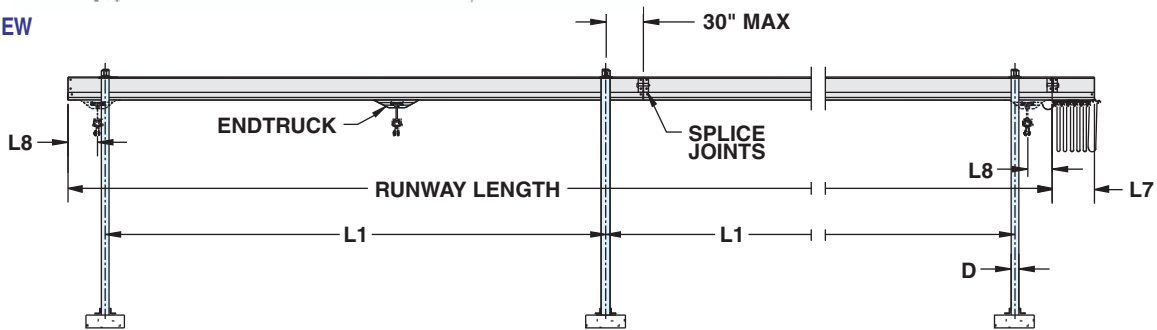

TOP VIEW

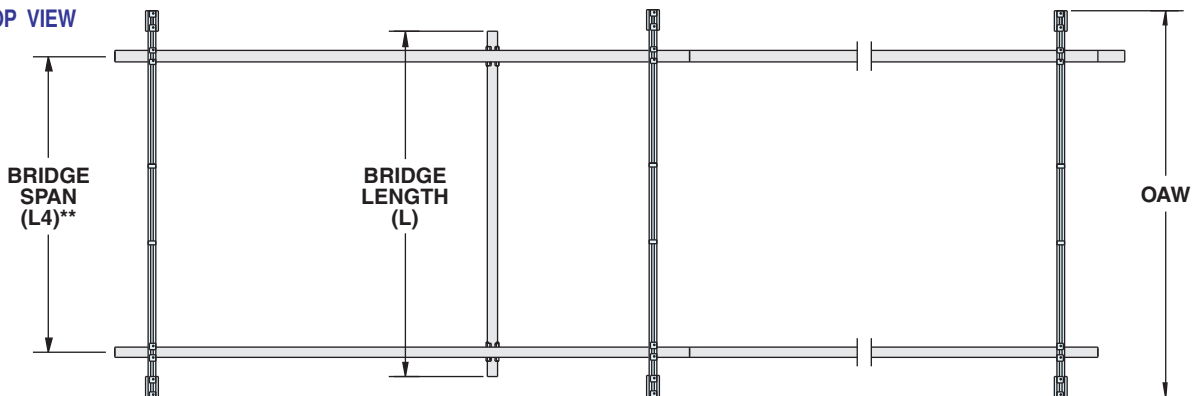

FREE STANDING WORK STATION BRIDGE CRANES

BRIDGE LENGTH (L)	RUNWAY LENGTH	TS	MODEL NUMBER	TRACK MAT.	RUNWAY			BRIDGE						SUPPORT STRUCTURE			
					MAX. L1	L7 in	L8 in	H3 in	H3A in	H4 in	L3 in	L6 in	OAW	OAH	D in	T-ops	
10'	11'6"	10'	GLCS-FS-250-10 (S or AL)-11.5-10	Steel	20'	9	10-3/4	12-7/8	20-5/8	4-3/4	5-1/8	8-3/4	11'-4"	11'-5-3/8"	3	2	
		12'	GLCS-FS-250-10 (S or AL)-11.5-12	Steel	20'	9	10-3/4	12-7/8	20-5/8	4-3/4	5-1/8	8-3/4	11'-4"	13'-5-3/8"	3	2	
		14'	GLCS-FS-250-10 (S or AL)-11.5-14	Steel	20'	9	10-3/4	12-7/8	20-5/8	4-3/4	5-1/8	8-3/4	11'-4"	15'-5-3/8"	3	2	
	23'	10'	GLCS-FS-250-10 (S or AL)-23-10	Steel	20'	9	10-3/4	12-7/8	20-5/8	4-3/4	5-1/8	8-3/4	11'-4"	11'-5-3/8"	3	2	
		12'	AL-FS-250-10-23-10	Alum	20'	13	13-1/4	20	-	10-3/4	7-1/4	16-7/8	11'-4"	12'-0-1/2"	3	2	
		12'	GLCS-FS-250-10 (S or AL)-23-12	Steel	20'	9	10-3/4	12-7/8	20-5/8	4-3/4	5-1/8	8-3/4	11'-4"	13'-5-3/8"	3	2	
		12'	AL-FS-250-10-23-12	Alum	20'	13	13-1/4	20	-	10-3/4	7-1/4	16-7/8	11'-4"	14'-0-1/2"	3	2	
		14'	GLCS-FS-250-10 (S or AL)-23-14	Steel	20'	9	10-3/4	12-7/8	20-5/8	4-3/4	5-1/8	8-3/4	11'-4"	15'-5-3/8"	3	2	
		14'	AL-FS-250-10-23-14	Alum	20'	13	13-1/4	20	-	10-3/4	7-1/4	16-7/8	11'-4"	16'-0-1/2"	3	2	
	28'	10'	GLCSL-FS-250-10 (S or AL)-28-10	Steel	25'	9	10-3/4	14-7/8	22-5/8	4-3/4	5-1/8	8-3/4	11'-4"	11'-7-3/8"	3	2	
		12'	GLCSL-FS-250-10 (S or AL)-28-12	Steel	25'	9	10-3/4	14-7/8	22-5/8	4-3/4	5-1/8	8-3/4	11'-4"	13'-7-3/8"	3	2	
		14'	GLCSL-FS-250-10 (S or AL)-28-14	Steel	25'	9	10-3/4	14-7/8	22-5/8	4-3/4	5-1/8	8-3/4	11'-4"	15'-7-3/8"	3	2	
	33'	10'	GLCS-FS-250-10 (S or AL)-33-10	Steel	20'	9	10-3/4	12-7/8	20-5/8	4-3/4	5-1/8	8-3/4	11'-4"	11'-5-3/8"	3	3	
		10'	AL-FS-250-10-33-10	Alum	20'	19	13-1/4	20	-	10-3/4	7-1/4	16-7/8	11'-4"	12'-0-1/2"	3	3	
		12'	GLCS-FS-250-10 (S or AL)-33-12	Steel	20'	9	10-3/4	12-7/8	20-5/8	4-3/4	5-1/8	8-3/4	11'-4"	13'-5-3/8"	3	3	
		12'	AL-FS-250-10-33-12	Alum	20'	19	13-1/4	20	-	10-3/4	7-1/4	16-7/8	11'-4"	14'-0-1/2"	3	3	
		14'	GLCS-FS-250-10 (S or AL)-33-14	Steel	20'	9	10-3/4	12-7/8	20-5/8	4-3/4	5-1/8	8-3/4	11'-4"	15'-5-3/8"	3	3	
		14'	AL-FS-250-10-33-14	Alum	20'	19	13-1/4	20	-	10-3/4	7-1/4	16-7/8	11'-4"	16'-0-1/2"	3	3	
	43'	10'	GLCS-FS-250-10 (S or AL)-43-10	Steel	20'	13	10-3/4	12-7/8	20-5/8	4-3/4	5-1/8	8-3/4	11'-4"	11'-5-3/8"	3	3	
		10'	AL-FS-250-10-43-10	Alum	20'	26	13-1/4	20	-	10-3/4	7-1/4	16-7/8	11'-4"	12'-0-1/2"	3	3	
		12'	GLCS-FS-250-10 (S or AL)-43-12	Steel	20'	13	10-3/4	12-7/8	20-5/8	4-3/4	5-1/8	8-3/4	11'-4"	13'-5-3/8"	3	3	
		12'	AL-FS-250-10-43-12	Alum	20'	26	13-1/4	20	-	10-3/4	7-1/4	16-7/8	11'-4"	14'-0-1/2"	3	3	
		14'	GLCS-FS-250-10 (S or AL)-43-14	Steel	20'	13	10-3/4	12-7/8	20-5/8	4-3/4	5-1/8	8-3/4	11'-4"	15'-5-3/8"	3	3	
		14'	AL-FS-250-10-43-14	Alum	20'	26	13-1/4	20	-	10-3/4	7-1/4	16-7/8	11'-4"	16'-0-1/2"	3	3	
	53'	10'	GLCS-FS-250-10 (S or AL)-53-10	Steel	20'	13	10-3/4	12-7/8	20-5/8	4-3/4	5-1/8	8-3/4	11'-4"	11'-5-3/8"	3	4	
		10'	AL-FS-250-10-53-10	Alum	20'	30	13-1/4	20	-	10-3/4	7-1/4	16-7/8	11'-4"	12'-0-1/2"	3	4	
		12'	GLCSL-FS-250-10 (S or AL)-53-10	Steel	25'	13	10-3/4	14-7/8	22-5/8	4-3/4	5-1/8	8-3/4	11'-4"	11'-7-3/8"	3	4	
		12'	GLCS-FS-250-10 (S or AL)-53-12	Steel	20'	13	10-3/4	12-7/8	20-5/8	4-3/4	5-1/8	8-3/4	11'-4"	13'-5-3/8"	3	4	
		12'	AL-FS-250-10-53-12	Alum	20'	30	13-1/4	20	-	10-3/4	7-1/4	16-7/8	11'-4"	14'-0-1/2"	3	4	
		14'	GLCSL-FS-250-10 (S or AL)-53-12	Steel	25'	13	10-3/4	14-7/8	22-5/8	4-3/4	5-1/8	8-3/4	11'-4"	13'-7-3/8"	3	4	
	63'	10'	GLCS-FS-250-10 (S or AL)-63-10	Steel	20'	19	10-3/4	12-7/8	20-5/8	4-3/4	5-1/8	8-3/4	11'-4"	11'-5-3/8"	3	4	
		10'	AL-FS-250-10-63-10	Alum	20'	36	13-1/4	20	-	10-3/4	7-1/4	16-7/8	11'-4"	12'-0-1/2"	3	4	
		12'	GLCS-FS-250-10 (S or AL)-63-12	Steel	20'	19	10-3/4	12-7/8	20-5/8	4-3/4	5-1/8	8-3/4	11'-4"	13'-5-3/8"	3	4	
		12'	AL-FS-250-10-63-12	Alum	20'	36	13-1/4	20	-	10-3/4	7-1/4	16-7/8	11'-4"	14'-0-1/2"	3	4	
		14'	GLCS-FS-250-10 (S or AL)-63-14	Steel	20'	19	10-3/4	12-7/8	20-5/8	4-3/4	5-1/8	8-3/4	11'-4"	15'-5-3/8"	3	4	
		14'	AL-FS-250-10-63-14	Alum	20'	36	13-1/4	20	-	10-3/4	7-1/4	16-7/8	11'-4"	16'-0-1/2"	3	4	
	78'	10'	GLCSL-FS-250-10 (S or AL)-78-10	Steel	25'	46	10-3/4	14-7/8	22-5/8	4-3/4	5-1/8	15-1/8	11'-4"	11'-7-3/8"	3	4	
		12'	GLCSL-FS-250-10 (S or AL)-78-12	Steel	25'	46	10-3/4	14-7/8	22-5/8	4-3/4	5-1/8	15-1/8	11'-4"	13'-7-3/8"	3	4	
		14'	GLCSL-FS-250-10 (S or AL)-78-14	Steel	25'	46	10-3/4	14-7/8	22-5/8	4-3/4	5-1/8	15-1/8	11'-4"	15'-7-3/8"	3	4	
	83'	10'	GLCS-FS-250-10 (S or AL)-83-10	Steel	20'	46	10-3/4	12-7/8	20-5/8	4-3/4	5-1/8	15-1/8	11'-4"	11'-5-3/8"	3	5	
		10'	AL-FS-250-10-83-10	Alum	20'	46	13-1/4	20	-	10-3/4	7-1/4	16-7/8	11'-4"	12'-0-1/2"	3	5	
		12'	GLCS-FS-250-10 (S or AL)-83-12	Steel	20'	46	10-3/4	12-7/8	20-5/8	4-3/4	5-1/8	15-1/8	11'-4"	13'-5-3/8"	3	5	
		12'	AL-FS-250-10-83-12	Alum	20'	46	13-1/4	20	-	10-3/4	7-1/4	16-7/8	11'-4"	14'-0-1/2"	3	5	
		14'	GLCS-FS-250-10 (S or AL)-83-14	Steel	20'	46	10-3/4	12-7/8	20-5/8	4-3/4	5-1/8	15-1/8	11'-4"	15'-5-3/8"	3	5	
		14'	AL-FS-250-10-83-14	Alum	20'	46	13-1/4	20	-	10-3/4	7-1/4	16-7/8	11'-4"	16'-0-1/2"	3	5	
	103'	10'	GLCS-FS-250-10 (S or AL)-103-10	Steel	20'	54	10-3/4	12-7/8	20-5/8	4-3/4	5-1/8	15-1/8	11'-4"	11'-5-3/8"	3	6	
		10'	AL-FS-250-10-103-10	Alum	20'	54	13-1/4	20	-	10-3/4	7-1/4	16-7/8	11'-4"	12'-0-1/2"	3	6	
		12'	GLCSL-FS-250-10 (S or AL)-103-10	Steel	25'	54	10-3/4	14-7/8	22-5/8	4-3/4	5-1/8	15-1/8	11'-4"	11'-7-3/8"	3	6	
		12'	GLCS-FS-250-10 (S or AL)-103-12	Steel	20'	54	10-3/4	12-7/8	20-5/8	4-3/4	5-1/8	15-1/8	11'-4"	13'-5-3/8"	3	6	
		12'	AL-FS-250-10-103-12	Alum	20'	54	13-1/4	20	-	10-3/4	7-1/4	16-7/8	11'-4"	14'-0-1/2"	3	6	
		14'	GLCSL-FS-250-10 (S or AL)-103-12	Steel	25'	54	10-3/4	14-7/8	22-5/8	4-3/4	5-1/8	15-1/8	11'-4"	13'-7-3/8"	3	6	
	103'	14'	GLCS-FS-250-10 (S or AL)-103-14	Steel	20'	54	10-3/4	12-7/8	20-5/8	4-3/4	5-1/8	15-1/8	11'-4"	15'-5-3/8"	3	6	
		14'	AL-FS-250-10-103-14	Alum	20'	54	13-1/4	20	-	10-3/4	7-1/4	16-7/8	11'-4"	16'-0-1/2"	3	6	
		14'	GLCSL-FS-250-10 (S or AL)-103-14	Steel	25'	54	10-3/4	14-7/8	22-5/8	4-3/4	5-1/8	15-1/8	11'-4"	15'-7-3/8"	3	6	
		14'	GLCSL-FS-250-10 (S or AL)-103-14	Steel	25'	54	10-3/4	14-7/8	22-5/8	4-3/4	5-1/8	15-1/8	11'-4"	15'-7-3/8"	3	6	

*This column provides the total number of support assemblies based on the "L1" dimensions shown. Support assemblies are designed to AISC specifications and do not require bracing. If no movement of the support assembly is preferred, then bracing to the building steel is recommended (not included).

To Determine Hook Coverage: [Bridge Travel on Runway = Runway Length - (2xL8)] by [Hoist Trolley Travel on Bridge = Bridge Length - L3 - L6] (L6 allows for festoon stack-up).

Gorbel Free Standing Work Station Bridge Crane kits include: bridge, runways, the appropriate number of support assemblies, hoist trolley, end trucks, end stops, flat wire festooning, festoon gliders (festoon trolleys on steel runway lengths greater than 63' and all aluminum systems), festoon stack-up section, splice joints and hanger brackets. Hoist and anchor bolts provided by others.

Dimensions are for reference only and are subject to change without notice.

FREE STANDING WORK STATION BRIDGE CRANES

BRIDGE LENGTH (L)	RUNWAY LENGTH	TS	MODEL NUMBER	TRACK MAT.	RUNWAY			BRIDGE						SUPPORT STRUCTURE			
					MAX.	L7	L8	H3	H3A	H4	L3	L6	OAW	OAH	D	-L4S	
					L1	in	in	in	in	in	in	in	in	in	in		
15'	23'	10'	GLCS-FS-250-15 (S or AL)-23-10	Steel	20'	9	10-3/4	12-7/8	20-5/8	10-1/2	5-1/8	11-1/4	16'-4"	11'-5-3/8"	3	2	
		10'	AL-FS-250-15-23-10	Alum	20'	13	13-1/4	20	-	10-3/4	7-1/4	23-5/8	16'-4"	12'-0-1/2"	3	2	
		12'	GLCSL-FS-250-15 (S or AL)-23-12	Steel	20'	9	10-3/4	12-7/8	20-5/8	10-1/2	5-1/8	11-1/4	16'-4"	13'-5-3/8"	3	2	
		12'	AL-FS-250-15-23-12	Alum	20'	13	13-1/4	20	-	10-3/4	7-1/4	23-5/8	16'-4"	14'-0-1/2"	3	2	
	28'	10'	GLCSL-FS-250-15 (S or AL)-28-10	Steel	25'	9	10-3/4	14-7/8	22-5/8	10-1/2	5-1/8	11-1/4	16'-4"	11'-7-3/8"	3	2	
		12'	GLCSL-FS-250-15 (S or AL)-28-12	Steel	25'	9	10-3/4	14-7/8	22-5/8	10-1/2	5-1/8	11-1/4	16'-4"	13'-7-3/8"	3	2	
		14'	GLCSL-FS-250-15 (S or AL)-28-14	Steel	25'	9	10-3/4	14-7/8	22-5/8	10-1/2	5-1/8	11-1/4	16'-4"	15'-7-3/8"	3	2	
		14'	AL-FS-250-15-33-14	Alum	20'	13	13-1/4	20	-	10-3/4	7-1/4	23-5/8	16'-4"	16'-0-1/2"	3	2	
	33'	10'	GLCS-FS-250-15 (S or AL)-33-10	Steel	20'	9	10-3/4	12-7/8	20-5/8	10-1/2	5-1/8	11-1/4	16'-4"	11'-5-3/8"	3	3	
		10'	AL-FS-250-15-33-10	Alum	20'	19	13-1/4	20	-	10-3/4	7-1/4	23-5/8	16'-4"	12'-0-1/2"	3	3	
		12'	GLCSL-FS-250-15 (S or AL)-33-12	Steel	20'	9	10-3/4	12-7/8	20-5/8	10-1/2	5-1/8	11-1/4	16'-4"	13'-5-3/8"	3	3	
		12'	AL-FS-250-15-33-12	Alum	20'	19	13-1/4	20	-	10-3/4	7-1/4	23-5/8	16'-4"	14'-0-1/2"	3	3	
	43'	10'	GLCS-FS-250-15 (S or AL)-43-10	Steel	20'	11	10-3/4	12-7/8	20-5/8	10-1/2	5-1/8	11-1/4	16'-4"	11'-5-3/8"	3	3	
		10'	AL-FS-250-15-43-10	Alum	20'	26	13-1/4	20	-	10-3/4	7-1/4	23-5/8	16'-4"	12'-0-1/2"	3	3	
		12'	GLCSL-FS-250-15 (S or AL)-43-12	Steel	20'	11	10-3/4	12-7/8	20-5/8	10-1/2	5-1/8	11-1/4	16'-4"	13'-5-3/8"	3	3	
		12'	AL-FS-250-15-43-12	Alum	20'	26	13-1/4	20	-	10-3/4	7-1/4	23-5/8	16'-4"	14'-0-1/2"	3	3	
	53'	10'	GLCS-FS-250-15 (S or AL)-53-10	Steel	20'	11	10-3/4	12-7/8	20-5/8	10-1/2	5-1/8	11-1/4	16'-4"	11'-5-3/8"	3	3	
		10'	AL-FS-250-15-53-10	Alum	20'	30	13-1/4	20	-	10-3/4	7-1/4	23-5/8	16'-4"	12'-0-1/2"	3	3	
		12'	GLCSL-FS-250-15 (S or AL)-53-12	Steel	25'	13	10-3/4	14-7/8	22-5/8	10-1/2	5-1/8	11-1/4	16'-4"	11'-7-3/8"	3	3	
		12'	AL-FS-250-15-53-12	Alum	20'	30	13-1/4	20	-	10-3/4	7-1/4	23-5/8	16'-4"	14'-0-1/2"	3	3	
	53'	12'	GLCSL-FS-250-15 (S or AL)-53-12	Steel	25'	13	10-3/4	14-7/8	22-5/8	10-1/2	5-1/8	11-1/4	16'-4"	13'-7-3/8"	3	3	
		14'	GLCS-FS-250-15 (S or AL)-53-14	Steel	20'	13	10-3/4	12-7/8	20-5/8	10-1/2	5-1/8	11-1/4	16'-4"	15'-5-3/8"	3	4	
		14'	AL-FS-250-15-53-14	Alum	20'	30	13-1/4	20	-	10-3/4	7-1/4	23-5/8	16'-4"	16'-0-1/2"	3	4	
		14'	GLCSL-FS-250-15 (S or AL)-53-14	Steel	25'	13	10-3/4	14-7/8	22-5/8	10-1/2	5-1/8	11-1/4	16'-4"	15'-7-3/8"	3	3	
	63'	10'	GLCS-FS-250-15 (S or AL)-63-10	Steel	20'	15	10-3/4	12-7/8	20-5/8	10-1/2	5-1/8	11-1/4	16'-4"	11'-5-3/8"	3	4	
		10'	AL-FS-250-15-63-10	Alum	20'	36	13-1/4	20	-	10-3/4	7-1/4	23-5/8	16'-4"	12'-0-1/2"	3	4	
		12'	GLCSL-FS-250-15 (S or AL)-63-12	Steel	20'	15	10-3/4	12-7/8	20-5/8	10-1/2	5-1/8	11-1/4	16'-4"	13'-5-3/8"	3	4	
		12'	AL-FS-250-15-63-12	Alum	20'	36	13-1/4	20	-	10-3/4	7-1/4	23-5/8	16'-4"	14'-0-1/2"	3	4	
	63'	14'	GLCS-FS-250-15 (S or AL)-63-14	Steel	20'	15	10-3/4	12-7/8	20-5/8	10-1/2	5-1/8	11-1/4	16'-4"	15'-5-3/8"	3	4	
		14'	AL-FS-250-15-63-14	Alum	20'	36	13-1/4	20	-	10-3/4	7-1/4	23-5/8	16'-4"	16'-0-1/2"	3	4	
		14'	GLCSL-FS-250-15 (S or AL)-63-14	Steel	25'	15	10-3/4	14-7/8	22-5/8	10-1/2	5-1/8	11-1/4	16'-4"	13'-7-3/8"	3	4	
		14'	AL-FS-250-15-63-14	Alum	20'	36	13-1/4	20	-	10-3/4	7-1/4	23-5/8	16'-4"	16'-0-1/2"	3	4	
	78'	10'	GLCSL-FS-250-15 (S or AL)-78-10	Steel	25'	46	10-3/4	14-7/8	22-5/8	10-1/2	5-1/8	21-7/8	16'-4"	11'-5-3/8"	3	4	
		12'	GLCSL-FS-250-15 (S or AL)-78-12	Steel	25'	46	10-3/4	14-7/8	22-5/8	10-1/2	5-1/8	21-7/8	16'-4"	13'-7-3/8"	3	4	
		14'	GLCSL-FS-250-15 (S or AL)-78-14	Steel	25'	46	10-3/4	14-7/8	22-5/8	10-1/2	5-1/8	21-7/8	16'-4"	15'-7-3/8"	3	4	
	83'	10'	GLCS-FS-250-15 (S or AL)-83-10	Steel	20'	46	10-3/4	12-7/8	20-5/8	10-1/2	5-1/8	21-7/8	16'-4"	11'-5-3/8"	3	5	
		10'	AL-FS-250-15-83-10	Alum	20'	46	13-1/4	20	-	10-3/4	7-1/4	23-5/8	16'-4"	12'-0-1/2"	3	5	
		12'	GLCSL-FS-250-15 (S or AL)-83-12	Steel	20'	46	10-3/4	12-7/8	20-5/8	10-1/2	5-1/8	21-7/8	16'-4"	13'-5-3/8"	3	5	
		12'	AL-FS-250-15-83-12	Alum	20'	46	13-1/4	20	-	10-3/4	7-1/4	23-5/8	16'-4"	14'-0-1/2"	3	5	
	103'	14'	GLCS-FS-250-15 (S or AL)-83-14	Steel	20'	46	10-3/4	12-7/8	20-5/8	10-1/2	5-1/8	21-7/8	16'-4"	15'-5-3/8"	3	5	
		14'	AL-FS-250-15-83-14	Alum	20'	46	13-1/4	20	-	10-3/4	7-1/4	23-5/8	16'-4"	16'-0-1/2"	3	5	
		10'	GLCS-FS-250-15 (S or AL)-103-10	Steel	20'	54	10-3/4	12-7/8	20-5/8	10-1/2	5-1/8	21-7/8	16'-4"	11'-5-3/8"	3	6	
		10'	AL-FS-250-15-103-10	Alum	20'	54	13-1/4	20	-	10-3/4	7-1/4	23-5/8	16'-4"	12'-0-1/2"	3	6	
	103'	10'	GLCSL-FS-250-15 (S or AL)-103-10	Steel	25'	54	10-3/4	14-7/8	22-5/8	10-1/2	5-1/8	21-7/8	16'-4"	11'-7-3/8"	3	5	
		12'	GLCSL-FS-250-15 (S or AL)-103-12	Steel	20'	54	10-3/4	12-7/8	20-5/8	10-1/2	5-1/8	21-7/8	16'-4"	13'-5-3/8"	3	6	
		12'	AL-FS-250-15-103-12	Alum	20'	54	13-1/4	20	-	10-3/4	7-1/4	23-5/8	16'-4"	14'-0-1/2"	3	6	
		12'	GLCSL-FS-250-15 (S or AL)-103-12	Steel	25'	54	10-3/4	14-7/8	22-5/8	10-1/2	5-1/8	21-7/8	16'-4"	13'-7-3/8"	3	5	
	103'	14'	GLCS-FS-250-15 (S or AL)-103-14	Steel	20'	54	10-3/4	12-7/8	20-5/8	10-1/2	5-1/8	21-7/8	16'-4"	15'-5-3/8"	3	6	
14'		AL-FS-250-15-103-14	Alum	20'	54	13-1/4	20	-	10-3/4	7-1/4	23-5/8	16'-4"	16'-0-1/2"	3	6		
103'	14'	GLCSL-FS-250-15 (S or AL)-103-14	Steel	25'	54	10-3/4	14-7/8	22-5/8	10-1/2	5-1/8	21-7/8	16'-4"	15'-7-3/8"	3	5		

*This column provides the total number of support assemblies based on the "L1" dimensions shown. Support assemblies are designed to AISC specifications and do not require bracing. If no movement of the support assembly is preferred, then bracing to the building steel is recommended (not included).
To Determine Hook Coverage: [Bridge Travel on Runway = Runway Length - (2xL8)] by [Hoist Trolley Travel on Bridge = Bridge Length - L3 - L6] (L6 allows for festoon stack-up).
Gorbel Free Standing Work Station Bridge Crane kits include: bridge, runways, the appropriate number of support assemblies, hoist trolley, end trucks, end stops, flat wire festooning, festoon gliders (festoon trolleys on steel runway lengths greater than 63' and all aluminum systems), festoon stack-up section, splice joints and hanger brackets. Hoist and anchor bolts provided by others.
Dimensions are for reference only and are subject to change without notice.

FREE STANDING WORK STATION BRIDGE CRANES

BRIDGE LENGTH (L)	RUNWAY LENGTH	TS	MODEL NUMBER	TRACK MAT.	RUNWAY			BRIDGE				SUPPORT STRUCTURE				
					MAX. L1	L7 in	L8 in	H3 in	H3A in	H4 in	L3 in	L6 in	OAW	OAH	D in	Spt
20'	23'	10'	GLCS-FS-250-20 (S or AL)-23-10	Steel	20'	9	10-3/4	12-7/8	20-5/8	10-1/2	5-1/8	19-1/2	21'-4"	11'-5-3/8"	3	2
		10'	AL-FS-250-20-23-10	Alum.	20'	13	13-1/4	20	-	10-3/4	7-1/4	27	21'-4"	12'-0-1/2"	3	2
		12'	GLCSL-FS-250-20 (S or AL)-23-12	Steel	20'	9	10-3/4	12-7/8	20-5/8	10-1/2	5-1/8	19-1/2	21'-4"	13'-5-3/8"	3	2
		12'	AL-FS-250-20-23-12	Alum.	20'	13	13-1/4	20	-	10-3/4	7-1/4	27	21'-4"	14'-0-1/2"	3	2
	28'	10'	GLCSL-FS-250-20 (S or AL)-28-10	Steel	25'	9	10-3/4	14-7/8	22-5/8	10-1/2	5-1/8	19-1/2	21'-4"	11'-7-3/8"	3	2
		10'	AL-FS-250-20-28-10	Alum.	25'	9	10-3/4	14-7/8	22-5/8	10-1/2	5-1/8	19-1/2	21'-4"	13'-7-3/8"	3	2
		12'	GLCSL-FS-250-20 (S or AL)-28-12	Steel	25'	9	10-3/4	14-7/8	22-5/8	10-1/2	5-1/8	19-1/2	21'-4"	15'-7-3/8"	3	2
		12'	AL-FS-250-20-28-12	Alum.	25'	9	10-3/4	14-7/8	22-5/8	10-1/2	5-1/8	19-1/2	21'-4"	15'-7-3/8"	3	2
	33'	10'	GLCS-FS-250-20 (S or AL)-33-10	Steel	20'	9	10-3/4	12-7/8	20-5/8	10-1/2	5-1/8	19-1/2	21'-4"	11'-5-3/8"	3	3
		10'	AL-FS-250-20-33-10	Alum.	20'	19	13-1/4	20	-	10-3/4	7-1/4	27	21'-4"	12'-0-1/2"	3	3
		12'	GLCS-FS-250-20 (S or AL)-33-12	Steel	20'	9	10-3/4	12-7/8	20-5/8	10-1/2	5-1/8	19-1/2	21'-4"	13'-5-3/8"	3	3
		12'	AL-FS-250-20-33-12	Alum.	20'	19	13-1/4	20	-	10-3/4	7-1/4	27	21'-4"	14'-0-1/2"	3	3
	43'	10'	GLCS-FS-250-20 (S or AL)-43-10	Steel	20'	11	10-3/4	12-7/8	20-5/8	10-1/2	5-1/8	19-1/2	21'-4"	11'-5-3/8"	3	3
		10'	AL-FS-250-20-43-10	Alum.	20'	26	13-1/4	20	-	10-3/4	7-1/4	27	21'-4"	12'-0-1/2"	3	3
		12'	GLCS-FS-250-20 (S or AL)-43-12	Steel	20'	11	10-3/4	12-7/8	20-5/8	10-1/2	5-1/8	19-1/2	21'-4"	13'-5-3/8"	3	3
		12'	AL-FS-250-20-43-12	Alum.	20'	26	13-1/4	20	-	10-3/4	7-1/4	27	21'-4"	14'-0-1/2"	3	3
	53'	10'	GLCS-FS-250-20 (S or AL)-53-10	Steel	20'	13	10-3/4	12-7/8	20-5/8	10-1/2	5-1/8	19-1/2	21'-4"	11'-5-3/8"	3	4
		10'	AL-FS-250-20-53-10	Alum.	20'	30	13-1/4	20	-	10-3/4	7-1/4	27	21'-4"	12'-0-1/2"	3	4
		12'	GLCSL-FS-250-20 (S or AL)-53-12	Steel	25'	13	10-3/4	14-7/8	22-5/8	10-1/2	5-1/8	19-1/2	21'-4"	11'-7-3/8"	3	4
		12'	AL-FS-250-20-53-12	Alum.	20'	30	13-1/4	20	-	10-3/4	7-1/4	27	21'-4"	13'-5-3/8"	3	4
	63'	10'	GLCSL-FS-250-20 (S or AL)-63-10	Steel	20'	13	10-3/4	12-7/8	20-5/8	10-1/2	5-1/8	19-1/2	21'-4"	11'-5-3/8"	3	4
		10'	AL-FS-250-20-63-10	Alum.	20'	36	13-1/4	20	-	10-3/4	7-1/4	27	21'-4"	12'-0-1/2"	3	4
		12'	GLCS-FS-250-20 (S or AL)-63-12	Steel	20'	15	10-3/4	12-7/8	20-5/8	10-1/2	5-1/8	19-1/2	21'-4"	13'-5-3/8"	3	4
		12'	AL-FS-250-20-63-12	Alum.	20'	36	13-1/4	20	-	10-3/4	7-1/4	27	21'-4"	14'-0-1/2"	3	4
	78'	10'	GLCS-FS-250-20 (S or AL)-78-10	Steel	20'	15	10-3/4	12-7/8	20-5/8	10-1/2	5-1/8	19-1/2	21'-4"	11'-5-3/8"	3	4
		10'	AL-FS-250-20-78-10	Alum.	20'	36	13-1/4	20	-	10-3/4	7-1/4	27	21'-4"	12'-0-1/2"	3	4
		12'	GLCSL-FS-250-20 (S or AL)-78-12	Steel	25'	46	10-3/4	14-7/8	22-5/8	10-1/2	5-1/8	25-1/4	21'-4"	13'-7-3/8"	3	4
		12'	AL-FS-250-20-78-12	Alum.	25'	46	10-3/4	14-7/8	22-5/8	10-1/2	5-1/8	25-1/4	21'-4"	15'-7-3/8"	3	4
	83'	10'	GLCS-FS-250-20 (S or AL)-83-10	Steel	20'	46	10-3/4	12-7/8	20-5/8	10-1/2	5-1/8	25-1/4	21'-4"	11'-5-3/8"	3	5
		10'	AL-FS-250-20-83-10	Alum.	20'	46	13-1/4	20	-	10-3/4	7-1/4	27	21'-4"	12'-0-1/2"	3	5
		12'	GLCS-FS-250-20 (S or AL)-83-12	Steel	20'	46	10-3/4	12-7/8	20-5/8	10-1/2	5-1/8	25-1/4	21'-4"	13'-5-3/8"	3	5
		12'	AL-FS-250-20-83-12	Alum.	20'	46	13-1/4	20	-	10-3/4	7-1/4	27	21'-4"	14'-0-1/2"	3	5
	103'	10'	GLCS-FS-250-20 (S or AL)-103-10	Steel	20'	54	10-3/4	12-7/8	20-5/8	10-1/2	5-1/8	25-1/4	21'-4"	11'-5-3/8"	3	6
		10'	AL-FS-250-20-103-10	Alum.	20'	54	13-1/4	20	-	10-3/4	7-1/4	27	21'-4"	12'-0-1/2"	3	6
		12'	GLCSL-FS-250-20 (S or AL)-103-12	Steel	25'	54	10-3/4	14-7/8	22-5/8	10-1/2	5-1/8	25-1/4	21'-4"	11'-7-3/8"	3	5
		12'	AL-FS-250-20-103-12	Alum.	20'	54	13-1/4	20	-	10-3/4	7-1/4	27	21'-4"	13'-5-3/8"	3	6
	103'	12'	GLCSL-FS-250-20 (S or AL)-103-12	Steel	25'	54	10-3/4	14-7/8	22-5/8	10-1/2	5-1/8	25-1/4	21'-4"	13'-7-3/8"	3	5
		12'	AL-FS-250-20-103-12	Alum.	20'	54	13-1/4	20	-	10-3/4	7-1/4	27	21'-4"	15'-5-3/8"	3	6
		14'	GLCS-FS-250-20 (S or AL)-103-14	Steel	20'	54	10-3/4	12-7/8	20-5/8	10-1/2	5-1/8	25-1/4	21'-4"	16'-0-1/2"	3	6
		14'	AL-FS-250-20-103-14	Alum.	20'	54	13-1/4	20	-	10-3/4	7-1/4	27	21'-4"	16'-0-1/2"	3	6

*This column provides the total number of support assemblies based on the "L1" dimensions shown. Support assemblies are designed to AISC specifications and do not require bracing. If no movement of the support assembly is preferred, then bracing to the building steel is recommended (not included).

To Determine Hook Coverage: [Bridge Travel on Runway = Runway Length - (2xL8)] by [Hoist Trolley Travel on Bridge = Bridge Length - L3 - L6] (L6 allows for festoon stack-up).

Gorbel Free Standing Work Station Bridge Crane kits include: bridge, runways, the appropriate number of support assemblies, hoist trolley, end trucks, end stops, flat wire festooning, festoon gliders (festoon trolleys on steel runway lengths greater than 63' and all aluminum systems), festoon stack-up section, splice joints and hanger brackets. Hoist and anchor bolts provided by others.

Dimensions are for reference only and are subject to change without notice.

FREE STANDING WORK STATION BRIDGE CRANES

BRIDGE LENGTH (L)	RUNWAY LENGTH	TS	MODEL NUMBER	TRACK MAT.	RUNWAY			BRIDGE					SUPPORT			
					MAX. L1	L7 in	L8 in	H3 in	H3A in	H4 in	L3 in	L6 in	OAW	OAH	D in	Sp
23'	23'	10'	GLCS-FS-250-23 (S or AL)-23-10	Steel	20'	9	10-3/4	12-7/8	20-5/8	10-1/2	5-1/8	19-1/2	24'-4"	11'-5-3/8"	3	2
		10'	AL-FS-250-23-23-10	Alum	20'	13	13-1/4	20	-	10-3/4	7-1/4	30-3/8	24'-4"	12'-0-1/2"	3	2
		12'	GLCSL-FS-250-23 (S or AL)-23-12	Steel	20'	9	10-3/4	12-7/8	22-5/8	10-1/2	5-1/8	19-1/2	24'-4"	13'-5-3/8"	3	2
		12'	AL-FS-250-23-23-12	Alum	20'	13	13-1/4	20	-	10-3/4	7-1/4	30-3/8	24'-4"	14'-0-1/2"	3	2
	28'	10'	GLCSL-FS-250-23 (S or AL)-28-10	Steel	25'	9	10-3/4	14-7/8	22-5/8	10-1/2	5-1/8	19-1/2	24'-4"	11'-7-3/8"	3	2
		12'	GLCSL-FS-250-23 (S or AL)-28-12	Steel	25'	9	10-3/4	14-7/8	22-5/8	10-1/2	5-1/8	19-1/2	24'-4"	13'-5-3/8"	3	2
		14'	GLCSL-FS-250-23 (S or AL)-28-14	Steel	25'	9	10-3/4	14-7/8	22-5/8	10-1/2	5-1/8	19-1/2	24'-4"	15'-7-3/8"	3	2
		14'	AL-FS-250-23-23-14	Alum	20'	13	13-1/4	20	-	10-3/4	7-1/4	30-3/8	24'-4"	16'-0-1/2"	3	2
	33'	10'	GLCS-FS-250-23 (S or AL)-33-10	Steel	20'	9	10-3/4	12-7/8	20-5/8	10-1/2	5-1/8	19-1/2	24'-4"	11'-5-3/8"	3	3
		10'	AL-FS-250-23-33-10	Alum	20'	19	13-1/4	20	-	10-3/4	7-1/4	30-3/8	24'-4"	12'-0-1/2"	3	3
		12'	GLCSL-FS-250-23 (S or AL)-33-12	Steel	20'	9	10-3/4	12-7/8	20-5/8	10-1/2	5-1/8	19-1/2	24'-4"	13'-5-3/8"	3	3
		12'	AL-FS-250-23-33-12	Alum	20'	19	13-1/4	20	-	10-3/4	7-1/4	30-3/8	24'-4"	14'-0-1/2"	3	3
	43'	10'	GLCS-FS-250-23 (S or AL)-43-10	Steel	20'	11	10-3/4	12-7/8	20-5/8	10-1/2	5-1/8	19-1/2	24'-4"	11'-5-3/8"	3	3
		10'	AL-FS-250-23-43-10	Alum	20'	26	13-1/4	20	-	10-3/4	7-1/4	30-3/8	24'-4"	12'-0-1/2"	3	3
		12'	GLCSL-FS-250-23 (S or AL)-43-12	Steel	20'	11	10-3/4	12-7/8	20-5/8	10-1/2	5-1/8	19-1/2	24'-4"	13'-5-3/8"	3	3
		12'	AL-FS-250-23-43-12	Alum	20'	26	13-1/4	20	-	10-3/4	7-1/4	30-3/8	24'-4"	14'-0-1/2"	3	3
	53'	10'	GLCS-FS-250-23 (S or AL)-53-10	Steel	20'	13	10-3/4	12-7/8	20-5/8	10-1/2	5-1/8	19-1/2	24'-4"	11'-5-3/8"	3	4
		10'	AL-FS-250-23-53-10	Alum	20'	30	13-1/4	20	-	10-3/4	7-1/4	30-3/8	24'-4"	12'-0-1/2"	3	4
		12'	GLCSL-FS-250-23 (S or AL)-53-12	Steel	25'	13	10-3/4	14-7/8	22-5/8	10-1/2	5-1/8	19-1/2	24'-4"	13'-5-3/8"	3	4
		12'	AL-FS-250-23-53-12	Alum	20'	30	13-1/4	20	-	10-3/4	7-1/4	30-3/8	24'-4"	14'-0-1/2"	3	4
	63'	10'	GLCSL-FS-250-23 (S or AL)-53-12	Steel	25'	13	10-3/4	14-7/8	22-5/8	10-1/2	5-1/8	19-1/2	24'-4"	13'-7-3/8"	3	4
		14'	GLCSL-FS-250-23 (S or AL)-53-14	Steel	20'	13	10-3/4	12-7/8	20-5/8	10-1/2	5-1/8	19-1/2	24'-4"	15'-5-3/8"	3	4
		14'	AL-FS-250-23-53-14	Alum	20'	30	13-1/4	20	-	10-3/4	7-1/4	30-3/8	24'-4"	16'-0-1/2"	3	4
		14'	GLCSL-FS-250-23 (S or AL)-53-14	Steel	25'	13	10-3/4	14-7/8	22-5/8	10-1/2	5-1/8	19-1/2	24'-4"	15'-7-3/8"	3	4
	78'	10'	GLCS-FS-250-23 (S or AL)-63-10	Steel	20'	15	10-3/4	12-7/8	20-5/8	10-1/2	5-1/8	19-1/2	24'-4"	11'-5-3/8"	3	4
		10'	AL-FS-250-23-63-10	Alum	20'	36	13-1/4	20	-	10-3/4	7-1/4	30-3/8	24'-4"	12'-0-1/2"	3	4
		12'	GLCSL-FS-250-23 (S or AL)-63-12	Steel	20'	15	10-3/4	12-7/8	20-5/8	10-1/2	5-1/8	19-1/2	24'-4"	13'-5-3/8"	3	4
		12'	AL-FS-250-23-63-12	Alum	20'	36	13-1/4	20	-	10-3/4	7-1/4	30-3/8	24'-4"	14'-0-1/2"	3	4
	83'	10'	GLCSL-FS-250-23 (S or AL)-63-12	Steel	20'	15	10-3/4	12-7/8	20-5/8	10-1/2	5-1/8	19-1/2	24'-4"	15'-5-3/8"	3	4
		14'	GLCSL-FS-250-23 (S or AL)-63-14	Steel	20'	36	13-1/4	20	-	10-3/4	7-1/4	30-3/8	24'-4"	16'-0-1/2"	3	4
		14'	AL-FS-250-23-63-14	Alum	20'	36	13-1/4	20	-	10-3/4	7-1/4	30-3/8	24'-4"	16'-0-1/2"	3	4
		14'	GLCSL-FS-250-23 (S or AL)-63-14	Steel	25'	46	10-3/4	14-7/8	22-5/8	10-1/2	5-1/8	30-3/8	24'-4"	11'-7-3/8"	3	4
	103'	10'	GLCSL-FS-250-23 (S or AL)-78-10	Steel	25'	46	10-3/4	14-7/8	22-5/8	10-1/2	5-1/8	30-3/8	24'-4"	13'-7-3/8"	3	4
		12'	GLCSL-FS-250-23 (S or AL)-78-12	Steel	25'	46	10-3/4	14-7/8	22-5/8	10-1/2	5-1/8	30-3/8	24'-4"	15'-7-3/8"	3	4
		14'	GLCSL-FS-250-23 (S or AL)-78-14	Steel	25'	46	10-3/4	14-7/8	22-5/8	10-1/2	5-1/8	30-3/8	24'-4"	15'-7-3/8"	3	4
		14'	AL-FS-250-23-78-14	Alum	20'	46	10-3/4	12-7/8	20-5/8	10-1/2	5-1/8	30-3/8	24'-4"	16'-0-1/2"	3	4
	103'	10'	GLCS-FS-250-23 (S or AL)-83-10	Steel	20'	46	10-3/4	12-7/8	20-5/8	10-1/2	5-1/8	30-3/8	24'-4"	11'-5-3/8"	3	5
		10'	AL-FS-250-23-83-10	Alum	20'	46	13-1/4	20	-	10-3/4	7-1/4	30-3/8	24'-4"	12'-0-1/2"	3	5
		12'	GLCSL-FS-250-23 (S or AL)-83-12	Steel	20'	46	10-3/4	12-7/8	20-5/8	10-1/2	5-1/8	30-3/8	24'-4"	13'-5-3/8"	3	5
		12'	AL-FS-250-23-83-12	Alum	20'	46	13-1/4	20	-	10-3/4	7-1/4	30-3/8	24'-4"	14'-0-1/2"	3	5
	103'	10'	GLCS-FS-250-23 (S or AL)-83-12	Steel	20'	46	10-3/4	12-7/8	20-5/8	10-1/2	5-1/8	30-3/8	24'-4"	15'-5-3/8"	3	5
		14'	GLCS-FS-250-23 (S or AL)-83-14	Steel	20'	46	10-3/4	12-7/8	20-5/8	10-1/2	5-1/8	30-3/8	24'-4"	15'-5-3/8"	3	5
		14'	AL-FS-250-23-83-14	Alum	20'	46	13-1/4	20	-	10-3/4	7-1/4	30-3/8	24'-4"	16'-0-1/2"	3	5
		14'	GLCSL-FS-250-23 (S or AL)-83-14	Steel	25'	46	10-3/4	14-7/8	22-5/8	10-1/2	5-1/8	30-3/8	24'-4"	15'-7-3/8"	3	5
	103'	10'	GLCSL-FS-250-23 (S or AL)-103-10	Steel	20'	54	10-3/4	12-7/8	20-5/8	10-1/2	5-1/8	30-3/8	24'-4"	11'-5-3/8"	3	6
		10'	AL-FS-250-23-103-10	Alum	20'	54	13-1/4	20	-	10-3/4	7-1/4	30-3/8	24'-4"	12'-0-1/2"	3	6
		12'	GLCSL-FS-250-23 (S or AL)-103-12	Steel	25'	54	10-3/4	14-7/8	22-5/8	10-1/2	5-1/8	30-3/8	24'-4"	13'-7-3/8"	3	6
		12'	AL-FS-250-23-103-12	Alum	20'	54	13-1/4	20	-	10-3/4	7-1/4	30-3/8	24'-4"	14'-0-1/2"	3	6
103'	10'	GLCSL-FS-250-23 (S or AL)-103-12	Steel	25'	54	10-3/4	14-7/8	22-5/8	10-1/2	5-1/8	30-3/8	24'-4"	13'-7-3/8"	3	6	
	14'	GLCSL-FS-250-23 (S or AL)-103-14	Steel	20'	54	10-3/4	12-7/8	20-5/8	10-1/2	5-1/8	30-3/8	24'-4"	15'-5-3/8"	3	6	
	14'	AL-FS-250-23-103-14	Alum	20'	54	13-1/4	20	-	10-3/4	7-1/4	30-3/8	24'-4"	16'-0-1/2"	3	6	
	14'	GLCSL-FS-250-23 (S or AL)-103-14	Steel	25'	54	10-3/4	14-7/8	22-5/8	10-1/2	5-1/8	30-3/8	24'-4"	15'-7-3/8"	3	6	

*This column provides the total number of support assemblies based on the "L1" dimensions shown. Support assemblies are designed to AISC specifications and do not require bracing. If no movement of the support assembly is preferred, then bracing to the building steel is recommended (not included).
To Determine Hook Coverage: [Bridge Travel on Runway = Runway Length - (2xL8)] by [Hoist Trolley Travel on Bridge = Bridge Length - L3 - L6] (L6 allows for festoon stack-up).
Gorbel Free Standing Work Station Bridge Crane kits include: bridge, runways, the appropriate number of support assemblies, hoist trolley, end trucks, end stops, flat wire festooning, festoon gliders (festoon trolleys on steel runway lengths greater than 63' and all aluminum systems), festoon stack-up section, splice joints and hanger brackets. Hoist and anchor bolts provided by others.
Dimensions are for reference only and are subject to change without notice.

FREE STANDING WORK STATION BRIDGE CRANES

BRIDGE LENGTH (L)	RUNWAY LENGTH	TS	MODEL NUMBER	TRACK MAT.	RUNWAY			BRIDGE				SUPPORT STRUCTURE				
					MAX. L1	L7 in	L8 in	H3 in	H3A in	H4 in	L3 in	L6 in	OAW	OAH	D in	-L6
28'	23'	10'	GLCS-FS-250-28 (S or AL)-23-10	Steel	20'	9	21-3/4	15-1/4	25-1/4	12-1/2	5-1/8	28-1/2	29'-4"	11'-8-3/4"	3	2
		10'	AL-FS-250-28-23-10	Alum	20'	13	23-3/8	24-3/8	-	12-5/8	7-1/4	37-1/8	29'-4"	12'-5-7/8"	3	2
		12'	GLCS-FS-250-28 (S or AL)-23-12	Steel	20'	9	21-3/4	15-1/4	25-1/4	12-1/2	5-1/8	28-1/2	29'-4"	13'-8-3/4"	3	2
		12'	AL-FS-250-28-23-12	Alum	20'	13	23-3/8	24-3/8	-	12-5/8	7-1/4	37-1/8	29'-4"	14'-5-7/8"	3	2
	14'	GLCS-FS-250-28 (S or AL)-23-14	Steel	20'	9	21-3/4	15-1/4	25-1/4	12-1/2	5-1/8	28-1/2	29'-4"	15'-8-3/4"	3	2	
	14'	AL-FS-250-28-23-14	Alum	20'	13	23-3/8	24-3/8	-	12-5/8	7-1/4	37-1/8	29'-4"	16'-5-7/8"	3	2	
	10'	GLCSL-FS-250-28 (S or AL)-28-10	Steel	25'	9	21-3/4	17-1/4	27-1/4	12-1/2	5-1/8	28-1/2	29'-4"	11'-10-3/4"	3	2	
	12'	GLCSL-FS-250-28 (S or AL)-28-12	Steel	25'	9	21-3/4	17-1/4	27-1/4	12-1/2	5-1/8	28-1/2	29'-4"	13'-10-3/4"	3	2	
	14'	GLCSL-FS-250-28 (S or AL)-28-14	Steel	25'	9	21-3/4	17-1/4	27-1/4	12-1/2	5-1/8	28-1/2	29'-4"	15'-10-3/4"	3	2	
	10'	GLCS-FS-250-28 (S or AL)-33-10	Steel	20'	9	21-3/4	15-1/4	25-1/4	12-1/2	5-1/8	28-1/2	29'-4"	11'-8-3/4"	3	3	
	10'	AL-FS-250-28-33-10	Alum	20'	19	23-3/8	24-3/8	-	12-5/8	7-1/4	37-1/8	29'-4"	12'-5-7/8"	3	3	
	12'	GLCS-FS-250-28 (S or AL)-33-12	Steel	20'	9	21-3/4	15-1/4	25-1/4	12-1/2	5-1/8	28-1/2	29'-4"	13'-8-3/4"	3	3	
12'	AL-FS-250-28-33-12	Alum	20'	19	23-3/8	24-3/8	-	12-5/8	7-1/4	37-1/8	29'-4"	14'-5-7/8"	3	3		
14'	GLCS-FS-250-28 (S or AL)-33-14	Steel	20'	9	21-3/4	15-1/4	25-1/4	12-1/2	5-1/8	28-1/2	29'-4"	15'-8-3/4"	3	3		
14'	AL-FS-250-28-33-14	Alum	20'	19	23-3/8	24-3/8	-	12-5/8	7-1/4	37-1/8	29'-4"	16'-5-7/8"	3	3		
10'	GLCS-FS-250-28 (S or AL)-43-10	Steel	20'	11	21-3/4	15-1/4	25-1/4	12-1/2	5-1/8	28-1/2	29'-4"	11'-8-3/4"	3	3		
10'	AL-FS-250-28-43-10	Alum	20'	26	23-3/8	24-3/8	-	12-5/8	7-1/4	37-1/8	29'-4"	12'-5-7/8"	3	3		
12'	GLCS-FS-250-28 (S or AL)-43-12	Steel	20'	11	21-3/4	15-1/4	25-1/4	12-1/2	5-1/8	28-1/2	29'-4"	13'-8-3/4"	3	3		
12'	AL-FS-250-28-43-12	Alum	20'	26	23-3/8	24-3/8	-	12-5/8	7-1/4	37-1/8	29'-4"	14'-5-7/8"	3	3		
14'	GLCS-FS-250-28 (S or AL)-43-14	Steel	20'	11	21-3/4	15-1/4	25-1/4	12-1/2	5-1/8	28-1/2	29'-4"	15'-8-3/4"	3	3		
14'	AL-FS-250-28-43-14	Alum	20'	26	23-3/8	24-3/8	-	12-5/8	7-1/4	37-1/8	29'-4"	16'-5-7/8"	3	3		
10'	GLCS-FS-250-28 (S or AL)-53-10	Steel	20'	13	21-3/4	15-1/4	25-1/4	12-1/2	5-1/8	28-1/2	29'-4"	11'-8-3/4"	3	4		
10'	AL-FS-250-28-53-10	Alum	20'	30	23-3/8	24-3/8	-	12-5/8	7-1/4	37-1/8	29'-4"	12'-5-7/8"	3	4		
12'	GLCSL-FS-250-28 (S or AL)-53-10	Steel	25'	13	21-3/4	17-1/4	27-1/4	12-1/2	5-1/8	28-1/2	29'-4"	11'-10-3/4"	3	4		
12'	GLCS-FS-250-28 (S or AL)-53-12	Steel	20'	13	21-3/4	15-1/4	25-1/4	12-1/2	5-1/8	28-1/2	29'-4"	13'-8-3/4"	3	4		
12'	AL-FS-250-28-53-12	Alum	20'	30	23-3/8	24-3/8	-	12-5/8	7-1/4	37-1/8	29'-4"	14'-5-7/8"	3	4		
12'	GLCSL-FS-250-28 (S or AL)-53-12	Steel	25'	13	21-3/4	17-1/4	27-1/4	12-1/2	5-1/8	28-1/2	29'-4"	13'-10-3/4"	3	4		
14'	GLCS-FS-250-28 (S or AL)-53-14	Steel	20'	13	21-3/4	15-1/4	25-1/4	12-1/2	5-1/8	28-1/2	29'-4"	15'-8-3/4"	3	4		
14'	AL-FS-250-28-53-14	Alum	20'	30	23-3/8	24-3/8	-	12-5/8	7-1/4	37-1/8	29'-4"	16'-5-7/8"	3	4		
14'	GLCSL-FS-250-28 (S or AL)-53-14	Steel	25'	13	21-3/4	17-1/4	27-1/4	12-1/2	5-1/8	28-1/2	29'-4"	15'-10-3/4"	3	4		
10'	GLCS-FS-250-28 (S or AL)-63-10	Steel	20'	15	21-3/4	15-1/4	25-1/4	12-1/2	5-1/8	35-3/8	29'-4"	11'-8-3/4"	3	4		
10'	AL-FS-250-28-63-10	Alum	20'	36	23-3/8	24-3/8	-	12-5/8	7-1/4	37-1/8	29'-4"	12'-5-7/8"	3	4		
12'	GLCS-FS-250-28 (S or AL)-63-12	Steel	20'	15	21-3/4	15-1/4	25-1/4	12-1/2	5-1/8	35-3/8	29'-4"	13'-8-3/4"	3	4		
12'	AL-FS-250-28-63-12	Alum	20'	36	23-3/8	24-3/8	-	12-5/8	7-1/4	37-1/8	29'-4"	14'-5-7/8"	3	4		
14'	GLCS-FS-250-28 (S or AL)-63-14	Steel	20'	15	21-3/4	15-1/4	25-1/4	12-1/2	5-1/8	35-3/8	29'-4"	15'-8-3/4"	3	4		
14'	AL-FS-250-28-63-14	Alum	20'	36	23-3/8	24-3/8	-	12-5/8	7-1/4	37-1/8	29'-4"	16'-5-7/8"	3	4		
10'	GLCSL-FS-250-28 (S or AL)-78-10	Steel	25'	46	21-3/4	17-1/4	27-1/4	12-1/2	5-1/8	35-3/8	29'-4"	11'-10-3/4"	3	4		
12'	GLCSL-FS-250-28 (S or AL)-78-12	Steel	25'	46	21-3/4	17-1/4	27-1/4	12-1/2	5-1/8	35-3/8	29'-4"	13'-10-3/4"	3	4		
14'	GLCSL-FS-250-28 (S or AL)-78-14	Steel	25'	46	21-3/4	17-1/4	27-1/4	12-1/2	5-1/8	35-3/8	29'-4"	15'-10-3/4"	3	4		
10'	GLCS-FS-250-28 (S or AL)-83-10	Steel	20'	46	21-3/4	15-1/4	25-1/4	12-1/2	5-1/8	35-3/8	29'-4"	11'-8-3/4"	3	5		
10'	AL-FS-250-28-83-10	Alum	20'	46	23-3/8	24-3/8	-	12-5/8	7-1/4	37-1/8	29'-4"	12'-5-7/8"	3	5		
12'	GLCS-FS-250-28 (S or AL)-83-12	Steel	20'	46	21-3/4	15-1/4	25-1/4	12-1/2	5-1/8	35-3/8	29'-4"	13'-8-3/4"	3	5		
12'	AL-FS-250-28-83-12	Alum	20'	46	23-3/8	24-3/8	-	12-5/8	7-1/4	37-1/8	29'-4"	14'-5-7/8"	3	5		
14'	GLCS-FS-250-28 (S or AL)-83-14	Steel	20'	46	21-3/4	15-1/4	25-1/4	12-1/2	5-1/8	35-3/8	29'-4"	15'-8-3/4"	3	5		
14'	AL-FS-250-28-83-14	Alum	20'	46	23-3/8	24-3/8	-	12-5/8	7-1/4	37-1/8	29'-4"	16'-5-7/8"	3	5		
10'	GLCS-FS-250-28 (S or AL)-103-10	Steel	20'	54	21-3/4	15-1/4	25-1/4	12-1/2	5-1/8	35-3/8	29'-4"	11'-8-3/4"	3	6		
10'	AL-FS-250-28-103-10	Alum	20'	54	23-3/8	24-3/8	-	12-5/8	7-1/4	37-1/8	29'-4"	12'-5-7/8"	3	6		
12'	GLCSL-FS-250-28 (S or AL)-103-10	Steel	25'	54	21-3/4	17-1/4	27-1/4	12-1/2	5-1/8	35-3/8	29'-4"	11'-10-3/4"	3	6		
12'	GLCS-FS-250-28 (S or AL)-103-12	Steel	20'	54	21-3/4	15-1/4	25-1/4	12-1/2	5-1/8	35-3/8	29'-4"	13'-8-3/4"	3	6		
12'	AL-FS-250-28-103-12	Alum	20'	54	23-3/8	24-3/8	-	12-5/8	7-1/4	37-1/8	29'-4"	14'-5-7/8"	3	6		
12'	GLCSL-FS-250-28 (S or AL)-103-12	Steel	25'	54	21-3/4	17-1/4	27-1/4	12-1/2	5-1/8	35-3/8	29'-4"	13'-10-3/4"	3	6		
14'	GLCS-FS-250-28 (S or AL)-103-14	Steel	20'	54	21-3/4	15-1/4	25-1/4	12-1/2	5-1/8	35-3/8	29'-4"	15'-8-3/4"	3	6		
14'	AL-FS-250-28-103-14	Alum	20'	54	23-3/8	24-3/8	-	12-5/8	7-1/4	37-1/8	29'-4"	16'-5-7/8"	3	6		
14'	GLCSL-FS-250-28 (S or AL)-103-14	Steel	25'	54	21-3/4	17-1/4	27-1/4	12-1/2	5-1/8	35-3/8	29'-4"	15'-10-3/4"	3	6		

*This column provides the total number of support assemblies based on the "L1" dimensions shown. Support assemblies are designed to AISC specifications and do not require bracing. If no movement of the support assembly is preferred, then bracing to the building steel is recommended (not included).
To Determine Hook Coverage: [Bridge Travel on Runway = Runway Length - (2xL8)] by [Hoist Trolley Travel on Bridge = Bridge Length - L3 - L6] (L6 allows for festoon stack-up).
Gorbel Free Standing Work Station Bridge Crane kits include: bridge, runways, the appropriate number of support assemblies, hoist trolley, end trucks, end stops, flat wire festooning, festoon gliders (festoon trolleys on steel runway lengths greater than 63' and all aluminum systems), festoon stack-up section, splice joints and hanger brackets. Hoist and anchor bolts provided by others.
Dimensions are for reference only and are subject to change without notice.

FREE STANDING WORK STATION BRIDGE CRANES

BRIDGE LENGTH (L)	RUNWAY LENGTH	TS	MODEL NUMBER	TRACK MAT.	RUNWAY			BRIDGE				SUPPORT				
					MAX L1	L7 in	L8 in	H3 in	H3A in	H4 in	L3 in	L6 in	OAW	OAH	D in	T-leg
10'	11' 6"	10'	GLCS-FS-500-10 (S or AL)-11.5-10	Steel	20'	9	13-1/8	16-1/2	24	6-5/8	7-1/8	10-1/2	11'-4"	11'-9"	3	2
		12'	GLCS-FS-500-10 (S or AL)-11.5-12	Steel	20'	9	13-1/8	16-1/2	24	6-5/8	7-1/8	10-1/2	11'-6"	13'-9"	4	2
		14'	GLCS-FS-500-10 (S or AL)-11.5-14	Steel	20'	9	13-1/8	16-1/2	24	6-5/8	7-1/8	10-1/2	11'-6"	15'-9"	4	2
	23'	10'	GLCS-FS-500-10 (S or AL)-23-10	Steel	20'	9	13-1/8	16-1/2	24	6-5/8	7-1/8	10-1/2	11'-4"	11'-9"	3	2
		10'	AL-FS-500-10-23-10	Alum	20'	13	13-1/4	23-7/8	-	12-5/8	7-1/4	16-7/8	11'-4"	12'-4-3/8"	3	2
		12'	GLCS-FS-500-10 (S or AL)-23-12	Steel	20'	9	13-1/8	16-1/2	24	6-5/8	7-1/8	10-1/2	11'-6"	13'-9"	4	2
		12'	AL-FS-500-10-23-12	Alum	20'	13	13-1/4	23-7/8	-	12-5/8	7-1/4	16-7/8	11'-6"	14'-4-3/8"	4	2
	28'	10'	GLCSL-FS-500-10 (S or AL)-28-10	Steel	25'	9	13-1/8	18-7/8	26-3/8	6-5/8	7-1/8	10-1/2	11'-4"	11'-11-3/8"	3	2
		12'	GLCSL-FS-500-10 (S or AL)-28-12	Steel	25'	9	13-1/8	18-7/8	26-3/8	6-5/8	7-1/8	10-1/2	11'-6"	13'-11-3/8"	4	2
		14'	GLCSL-FS-500-10 (S or AL)-28-14	Steel	25'	9	13-1/8	18-7/8	26-3/8	6-5/8	7-1/8	10-1/2	11'-6"	15'-11-3/8"	4	2
	33'	10'	GLCS-FS-500-10 (S or AL)-33-10	Steel	20'	9	13-1/8	16-1/2	24	6-5/8	7-1/8	10-1/2	11'-4"	11'-9"	3	3
		10'	AL-FS-500-10-33-10	Alum	20'	19	13-1/4	23-7/8	-	12-5/8	7-1/4	16-7/8	11'-4"	12'-4-3/8"	3	3
12'		GLCS-FS-500-10 (S or AL)-33-12	Steel	20'	9	13-1/8	16-1/2	24	6-5/8	7-1/8	10-1/2	11'-6"	13'-9"	4	3	
12'		AL-FS-500-10-33-12	Alum	20'	19	13-1/4	23-7/8	-	12-5/8	7-1/4	16-7/8	11'-6"	14'-4-3/8"	4	3	
34'	10'	GLCSLX-FS-500-10 (S or AL)-34-10	Steel	30'	9	13-1/8	20-7/8	28-3/8	6-5/8	7-1/8	10-1/2	11'-4"	12'-1-3/8"	3	2	
	12'	GLCSLX-FS-500-10 (S or AL)-34-12	Steel	30'	9	13-1/8	20-7/8	28-3/8	6-5/8	7-1/8	10-1/2	11'-6"	14'-1-3/8"	4	2	
	14'	GLCSLX-FS-500-10 (S or AL)-34-14	Steel	30'	9	13-1/8	20-7/8	28-3/8	6-5/8	7-1/8	10-1/2	11'-6"	16'-1-3/8"	4	2	
43'	10'	GLCS-FS-500-10 (S or AL)-43-10	Steel	20'	11	13-1/8	16-1/2	24	6-5/8	7-1/8	10-1/2	11'-4"	11'-9"	3	3	
	10'	AL-FS-500-10-43-10	Alum	20'	26	13-1/4	23-7/8	-	12-5/8	7-1/4	16-7/8	11'-4"	12'-4-3/8"	3	3	
	12'	GLCS-FS-500-10 (S or AL)-43-12	Steel	20'	11	13-1/8	16-1/2	24	6-5/8	7-1/8	10-1/2	11'-6"	13'-9"	4	3	
	12'	AL-FS-500-10-43-12	Alum	20'	26	13-1/4	23-7/8	-	12-5/8	7-1/4	16-7/8	11'-6"	14'-4-3/8"	4	3	
53'	10'	GLCS-FS-500-10 (S or AL)-53-10	Steel	20'	13	13-1/8	16-1/2	24	6-5/8	7-1/8	10-1/2	11'-4"	11'-9"	3	4	
	10'	AL-FS-500-10-53-10	Alum	20'	30	13-1/4	23-7/8	-	12-5/8	7-1/4	16-7/8	11'-4"	12'-4-3/8"	3	4	
	12'	GLCSL-FS-500-10 (S or AL)-53-12	Steel	25'	13	13-1/8	18-7/8	26-3/8	6-5/8	7-1/8	10-1/2	11'-4"	11'-11-3/8"	3	3	
	12'	GLCS-FS-500-10 (S or AL)-53-12	Steel	20'	13	13-1/8	16-1/2	24	6-5/8	7-1/8	10-1/2	11'-6"	13'-9"	4	4	
63'	10'	AL-FS-500-10-53-12	Alum	20'	30	13-1/4	23-7/8	-	12-5/8	7-1/4	16-7/8	11'-6"	14'-4-3/8"	4	4	
	12'	GLCSL-FS-500-10 (S or AL)-53-12	Steel	25'	13	13-1/8	18-7/8	26-3/8	6-5/8	7-1/8	10-1/2	11'-6"	13'-11-3/8"	4	3	
	12'	GLCS-FS-500-10 (S or AL)-53-14	Steel	20'	13	13-1/8	16-1/2	24	6-5/8	7-1/8	10-1/2	11'-6"	15'-9"	4	4	
	14'	AL-FS-500-10-53-14	Alum	20'	30	13-1/4	23-7/8	-	12-5/8	7-1/4	16-7/8	11'-6"	16'-4-3/8"	4	4	
64'	10'	GLCSL-FS-500-10 (S or AL)-53-14	Steel	25'	13	13-1/8	18-7/8	26-3/8	6-5/8	7-1/8	10-1/2	11'-6"	15'-11-3/8"	4	3	
	10'	GLCS-FS-500-10 (S or AL)-63-10	Steel	20'	15	13-1/8	16-1/2	24	6-5/8	7-1/8	10-1/2	11'-4"	11'-9"	3	4	
	10'	AL-FS-500-10-63-10	Alum	20'	36	13-1/4	23-7/8	-	12-5/8	7-1/4	16-7/8	11'-4"	12'-4-3/8"	3	4	
	12'	GLCS-FS-500-10 (S or AL)-63-12	Steel	20'	15	13-1/8	16-1/2	24	6-5/8	7-1/8	10-1/2	11'-6"	13'-9"	4	4	
64'	12'	AL-FS-500-10-63-12	Alum	20'	36	13-1/4	23-7/8	-	12-5/8	7-1/4	16-7/8	11'-6"	14'-4-3/8"	4	4	
	14'	GLCS-FS-500-10 (S or AL)-63-14	Steel	20'	15	13-1/8	16-1/2	24	6-5/8	7-1/8	10-1/2	11'-6"	15'-9"	4	4	
	14'	AL-FS-500-10-63-14	Alum	20'	36	13-1/4	23-7/8	-	12-5/8	7-1/4	16-7/8	11'-6"	16'-4-3/8"	4	4	
	10'	GLCSLX-FS-500-10 (S or AL)-64-10	Steel	30'	36	13-1/8	20-7/8	28-3/8	6-5/8	7-1/8	16-7/8	11'-4"	12'-1-3/8"	3	3	
78'	12'	GLCSLX-FS-500-10 (S or AL)-64-12	Steel	30'	36	13-1/8	20-7/8	28-3/8	6-5/8	7-1/8	16-7/8	11'-6"	14'-1-3/8"	4	3	
	14'	GLCSLX-FS-500-10 (S or AL)-64-14	Steel	30'	36	13-1/8	20-7/8	28-3/8	6-5/8	7-1/8	16-7/8	11'-6"	16'-1-3/8"	4	3	
	10'	GLCSL-FS-500-10 (S or AL)-78-10	Steel	25'	46	13-1/8	18-7/8	26-3/8	6-5/8	7-1/8	16-7/8	11'-4"	11'-11-3/8"	3	4	
	12'	GLCSL-FS-500-10 (S or AL)-78-12	Steel	25'	46	13-1/8	18-7/8	26-3/8	6-5/8	7-1/8	16-7/8	11'-6"	13'-11-3/8"	4	4	
83'	14'	GLCSL-FS-500-10 (S or AL)-78-14	Steel	25'	46	13-1/8	18-7/8	26-3/8	6-5/8	7-1/8	16-7/8	11'-6"	15'-11-3/8"	4	4	
	10'	GLCS-FS-500-10 (S or AL)-83-10	Steel	20'	46	13-1/8	16-1/2	24	6-5/8	7-1/8	16-7/8	11'-4"	11'-9"	3	5	
	10'	AL-FS-500-10-83-10	Alum	20'	46	13-1/4	23-7/8	-	12-5/8	7-1/4	16-7/8	11'-4"	12'-4-3/8"	3	5	
	12'	GLCS-FS-500-10 (S or AL)-83-12	Steel	20'	46	13-1/8	16-1/2	24	6-5/8	7-1/8	16-7/8	11'-6"	13'-9"	4	5	
94'	12'	AL-FS-500-10-83-12	Alum	20'	46	13-1/4	23-7/8	-	12-5/8	7-1/4	16-7/8	11'-6"	14'-4-3/8"	4	5	
	14'	GLCS-FS-500-10 (S or AL)-83-14	Steel	20'	46	13-1/8	16-1/2	24	6-5/8	7-1/8	16-7/8	11'-6"	15'-9"	4	5	
	14'	AL-FS-500-10-83-14	Alum	20'	46	13-1/4	23-7/8	-	12-5/8	7-1/4	16-7/8	11'-6"	16'-4-3/8"	4	5	
	10'	GLCSLX-FS-500-10 (S or AL)-94-10	Steel	30'	53	13-1/8	20-7/8	28-3/8	6-5/8	7-1/8	16-7/8	11'-4"	12'-1-3/8"	3	4	
103'	12'	GLCSLX-FS-500-10 (S or AL)-94-12	Steel	30'	53	13-1/8	20-7/8	28-3/8	6-5/8	7-1/8	16-7/8	11'-6"	14'-1-3/8"	4	4	
	14'	GLCSLX-FS-500-10 (S or AL)-94-14	Steel	30'	53	13-1/8	20-7/8	28-3/8	6-5/8	7-1/8	16-7/8	11'-6"	16'-1-3/8"	4	4	
	10'	GLCS-FS-500-10 (S or AL)-103-10	Steel	20'	54	13-1/8	16-1/2	24	6-5/8	7-1/8	16-7/8	11'-4"	11'-9"	3	6	
	10'	AL-FS-500-10-103-10	Alum	20'	54	13-1/4	23-7/8	-	12-5/8	7-1/4	16-7/8	11'-4"	12'-4-3/8"	3	6	
124'	12'	GLCSL-FS-500-10 (S or AL)-103-12	Steel	25'	54	13-1/8	18-7/8	26-3/8	6-5/8	7-1/8	16-7/8	11'-4"	11'-11-3/8"	3	5	
	12'	GLCS-FS-500-10 (S or AL)-103-12	Steel	20'	54	13-1/8	16-1/2	24	6-5/8	7-1/8	16-7/8	11'-6"	13'-9"	4	6	
	12'	AL-FS-500-10-103-12	Alum	20'	54	13-1/4	23-7/8	-	12-5/8	7-1/4	16-7/8	11'-6"	14'-4-3/8"	4	6	
	14'	GLCSL-FS-500-10 (S or AL)-103-14	Steel	25'	54	13-1/8	18-7/8	26-3/8	6-5/8	7-1/8	16-7/8	11'-6"	13'-11-3/8"	4	5	
124'	14'	GLCS-FS-500-10 (S or AL)-103-14	Steel	20'	54	13-1/8	16-1/2	24	6-5/8	7-1/8	16-7/8	11'-6"	15'-9"	4	6	
	14'	AL-FS-500-10-103-14	Alum	20'	54	13-1/4	23-7/8	-	12-5/8	7-1/4	16-7/8	11'-6"	16'-4-3/8"	4	6	
	10'	GLCSLX-FS-500-10 (S or AL)-124-10	Steel	30'	54	13-1/8	20-7/8	28-3/8	6-5/8	7-1/8	16-7/8	11'-4"	12'-1-3/8"	3	5	
	12'	GLCSLX-FS-500-10 (S or AL)-124-12	Steel	30'	54	13-1/8	20-7/8	28-3/8	6-5/8	7-1/8	16-7/8	11'-6"	14'-1-3/8"	4	5	
14'	GLCSLX-FS-500-10 (S or AL)-124-14	Steel	30'	54	13-1/8	20-7/8	28-3/8	6-5/8	7-1/8	16-7/8	11'-6"	16'-1-3/8"	4	5		

*This column provides the total number of support assemblies based on the "L1" dimensions shown. Support assemblies are designed to AISC specifications and do not require bracing. If no movement of the support assembly is preferred, then bracing to the building steel is recommended (not included).
To Determine Hook Coverage: [Bridge Travel on Runway = Runway Length - (2xL8)] by [Hoist Trolley Travel on Bridge = Bridge Length - L3 - L6] (L6 allows for festoon stack-up).
Goebel Free Standing Work Station Bridge Crane kits include: bridge, runways, the appropriate number of support assemblies, hoist trolley, and trucks, end stops, flat wire festooning, festoon gliders (festoon trolleys on steel runway lengths greater than 63' and all aluminum systems), festoon stack-up section, splice joints and hanger brackets. Hoist and anchor bolts provided by others.
Dimensions are for reference only and are subject to change without notice.

FREE STANDING WORK STATION BRIDGE CRANES

BRIDGE LENGTH (L)	RUNWAY LENGTH	TS	MODEL NUMBER	TRACK MAT.	RUNWAY			BRIDGE						SUPPORT STRUCTURE			
					MAX L1	L7 in	L8 in	H3 in	H3A in	H4 in	L3 in	L6 in	OAW	OAH	D in	-L ₆	
15'	23'	10'	GLCS-FS-500-15 (S or AL)-23-10	Steel	20'	9	13-1/8	16-1/2	24	12-3/4	7-1/8	21-3/4	16'-4"	11'-9"	3	2	
		10'	AL-FS-500-15-23-10	Alum	20'	13	13-1/4	23-7/8	-	12-5/8	7-1/4	23-5/8	16'-4"	12'-4-3/8"	3	2	
		12'	GLCS-FS-500-15 (S or AL)-23-12	Steel	20'	9	13-1/8	16-1/2	24	12-3/4	7-1/8	21-3/4	16'-6"	13'-9"	4	2	
		12'	AL-FS-500-15-23-12	Alum	20'	13	13-1/4	23-7/8	-	12-5/8	7-1/4	23-5/8	16'-6"	14'-4-3/8"	4	2	
	28'	10'	GLCS-FS-500-15 (S or AL)-23-14	Steel	20'	9	13-1/8	16-1/2	24	12-3/4	7-1/8	21-3/4	16'-6"	15'-9"	4	2	
		10'	AL-FS-500-15-23-14	Alum	20'	13	13-1/4	23-7/8	-	12-5/8	7-1/4	23-5/8	16'-6"	16'-4-3/8"	4	2	
		12'	GLCSL-FS-500-15 (S or AL)-28-10	Steel	25'	9	13-1/8	18-7/8	26-3/8	12-3/4	7-1/8	21-3/4	16'-4"	11'-11-3/8"	3	2	
		12'	GLCSL-FS-500-15 (S or AL)-28-12	Steel	25'	9	13-1/8	18-7/8	26-3/8	12-3/4	7-1/8	21-3/4	16'-6"	13'-11-3/8"	4	2	
	33'	12'	GLCSL-FS-500-15 (S or AL)-28-14	Steel	25'	9	13-1/8	18-7/8	26-3/8	12-3/4	7-1/8	21-3/4	16'-6"	15'-11-3/8"	4	2	
		10'	GLCS-FS-500-15 (S or AL)-33-10	Steel	20'	9	13-1/8	16-1/2	24	12-3/4	7-1/8	21-3/4	16'-4"	11'-9"	3	3	
		10'	AL-FS-500-15-23-10	Alum	20'	19	13-1/4	23-7/8	-	12-5/8	7-1/4	23-5/8	16'-4"	12'-4-3/8"	3	3	
		12'	GLCS-FS-500-15 (S or AL)-33-12	Steel	20'	9	13-1/8	16-1/2	24	12-3/4	7-1/8	21-3/4	16'-6"	13'-9"	4	3	
34'	12'	AL-FS-500-15-23-12	Alum	20'	19	13-1/4	23-7/8	-	12-5/8	7-1/4	23-5/8	16'-6"	14'-4-3/8"	4	3		
	14'	GLCS-FS-500-15 (S or AL)-33-14	Steel	20'	9	13-1/8	16-1/2	24	12-3/4	7-1/8	21-3/4	16'-6"	15'-9"	4	3		
	14'	AL-FS-500-15-23-14	Alum	20'	19	13-1/4	23-7/8	-	12-5/8	7-1/4	23-5/8	16'-6"	16'-4-3/8"	4	3		
	10'	GLCSLX-FS-500-15 (S or AL)-34-10	Steel	30'	9	13-1/8	20-7/8	28-3/8	12-3/4	7-1/8	21-3/4	16'-4"	12'-1-3/8"	3	2		
43'	12'	GLCSLX-FS-500-15 (S or AL)-34-12	Steel	30'	9	13-1/8	20-7/8	28-3/8	12-3/4	7-1/8	21-3/4	16'-6"	14'-1-3/8"	4	2		
	14'	GLCSLX-FS-500-15 (S or AL)-34-14	Steel	30'	9	13-1/8	20-7/8	28-3/8	12-3/4	7-1/8	21-3/4	16'-6"	16'-1-3/8"	4	2		
	10'	GLCS-FS-500-15 (S or AL)-43-10	Steel	20'	13	13-1/8	16-1/2	24	12-3/4	7-1/8	21-3/4	16'-4"	11'-9"	3	3		
	10'	AL-FS-500-15-23-10	Alum	20'	26	13-1/4	23-7/8	-	12-5/8	7-1/4	23-5/8	16'-4"	12'-4-3/8"	3	3		
53'	12'	GLCS-FS-500-15 (S or AL)-43-12	Steel	20'	13	13-1/8	16-1/2	24	12-3/4	7-1/8	21-3/4	16'-6"	13'-9"	4	3		
	12'	AL-FS-500-15-23-12	Alum	20'	26	13-1/4	23-7/8	-	12-5/8	7-1/4	23-5/8	16'-6"	14'-4-3/8"	4	3		
	14'	GLCS-FS-500-15 (S or AL)-43-14	Steel	20'	13	13-1/8	16-1/2	24	12-3/4	7-1/8	21-3/4	16'-6"	15'-9"	4	3		
	14'	AL-FS-500-15-23-14	Alum	20'	26	13-1/4	23-7/8	-	12-5/8	7-1/4	23-5/8	16'-6"	16'-4-3/8"	4	3		
63'	10'	GLCS-FS-500-15 (S or AL)-53-10	Steel	20'	13	13-1/8	16-1/2	24	12-3/4	7-1/8	21-3/4	16'-4"	11'-9"	3	4		
	10'	AL-FS-500-15-23-10	Alum	20'	30	13-1/4	23-7/8	-	12-5/8	7-1/4	23-5/8	16'-4"	12'-4-3/8"	3	4		
	12'	GLCSL-FS-500-15 (S or AL)-53-10	Steel	25'	13	13-1/8	18-7/8	26-3/8	12-3/4	7-1/8	21-3/4	16'-4"	11'-11-3/8"	3	3		
	12'	GLCSL-FS-500-15 (S or AL)-53-12	Steel	20'	13	13-1/8	16-1/2	24	12-3/4	7-1/8	21-3/4	16'-6"	13'-9"	4	4		
64'	12'	AL-FS-500-15-23-12	Alum	20'	30	13-1/4	23-7/8	-	12-5/8	7-1/4	23-5/8	16'-6"	14'-4-3/8"	4	4		
	14'	GLCSL-FS-500-15 (S or AL)-53-14	Steel	25'	13	13-1/8	18-7/8	26-3/8	12-3/4	7-1/8	21-3/4	16'-6"	13'-11-3/8"	4	3		
	14'	GLCS-FS-500-15 (S or AL)-53-14	Steel	20'	13	13-1/8	16-1/2	24	12-3/4	7-1/8	21-3/4	16'-6"	15'-9"	4	4		
	14'	AL-FS-500-15-23-14	Alum	20'	30	13-1/4	23-7/8	-	12-5/8	7-1/4	23-5/8	16'-6"	16'-4-3/8"	4	4		
78'	10'	GLCSLX-FS-500-15 (S or AL)-63-10	Steel	20'	19	13-1/8	16-1/2	24	12-3/4	7-1/8	21-3/4	16'-4"	11'-9"	3	4		
	10'	AL-FS-500-15-23-10	Alum	20'	36	13-1/4	23-7/8	-	12-5/8	7-1/4	23-5/8	16'-4"	12'-4-3/8"	3	4		
	12'	GLCS-FS-500-15 (S or AL)-63-12	Steel	20'	19	13-1/8	16-1/2	24	12-3/4	7-1/8	21-3/4	16'-6"	13'-9"	4	4		
	12'	AL-FS-500-15-23-12	Alum	20'	36	13-1/4	23-7/8	-	12-5/8	7-1/4	23-5/8	16'-6"	14'-4-3/8"	4	4		
83'	14'	GLCS-FS-500-15 (S or AL)-63-14	Steel	20'	19	13-1/8	16-1/2	24	12-3/4	7-1/8	21-3/4	16'-6"	15'-9"	4	4		
	14'	AL-FS-500-15-23-14	Alum	20'	36	13-1/4	23-7/8	-	12-5/8	7-1/4	23-5/8	16'-6"	16'-4-3/8"	4	4		
	10'	GLCSLX-FS-500-15 (S or AL)-64-10	Steel	30'	36	13-1/8	20-7/8	28-3/8	12-3/4	7-1/8	21-3/4	16'-4"	12'-1-3/8"	3	3		
	12'	GLCSLX-FS-500-15 (S or AL)-64-12	Steel	30'	36	13-1/8	20-7/8	28-3/8	12-3/4	7-1/8	21-3/4	16'-6"	14'-1-3/8"	4	3		
88'	14'	GLCSLX-FS-500-15 (S or AL)-64-14	Steel	30'	36	13-1/8	20-7/8	28-3/8	12-3/4	7-1/8	21-3/4	16'-6"	16'-1-3/8"	4	3		
	10'	GLCSL-FS-500-15 (S or AL)-78-10	Steel	25'	46	13-1/8	18-7/8	26-3/8	12-3/4	7-1/8	23-5/8	16'-4"	11'-11-3/8"	3	4		
	12'	GLCSL-FS-500-15 (S or AL)-78-12	Steel	25'	46	13-1/8	18-7/8	26-3/8	12-3/4	7-1/8	23-5/8	16'-6"	13'-11-3/8"	4	4		
	14'	GLCSL-FS-500-15 (S or AL)-78-14	Steel	25'	46	13-1/8	18-7/8	26-3/8	12-3/4	7-1/8	23-5/8	16'-6"	15'-11-3/8"	4	4		
94'	10'	GLCS-FS-500-15 (S or AL)-83-10	Steel	20'	46	13-1/8	16-1/2	24	12-3/4	7-1/8	23-5/8	16'-4"	11'-9"	3	5		
	10'	AL-FS-500-15-23-10	Alum	20'	46	13-1/4	23-7/8	-	12-5/8	7-1/4	23-5/8	16'-4"	12'-4-3/8"	3	5		
	12'	GLCS-FS-500-15 (S or AL)-83-12	Steel	20'	46	13-1/8	16-1/2	24	12-3/4	7-1/8	23-5/8	16'-6"	13'-9"	4	5		
	12'	AL-FS-500-15-23-12	Alum	20'	46	13-1/4	23-7/8	-	12-5/8	7-1/4	23-5/8	16'-6"	14'-4-3/8"	4	5		
103'	14'	GLCS-FS-500-15 (S or AL)-83-14	Steel	20'	46	13-1/8	16-1/2	24	12-3/4	7-1/8	23-5/8	16'-6"	15'-9"	4	5		
	14'	AL-FS-500-15-23-14	Alum	20'	46	13-1/4	23-7/8	-	12-5/8	7-1/4	23-5/8	16'-6"	16'-4-3/8"	4	5		
	10'	GLCSLX-FS-500-15 (S or AL)-94-10	Steel	30'	54	13-1/8	20-7/8	28-3/8	12-3/4	7-1/8	23-5/8	16'-4"	12'-1-3/8"	3	4		
	12'	GLCSLX-FS-500-15 (S or AL)-94-12	Steel	30'	54	13-1/8	20-7/8	28-3/8	12-3/4	7-1/8	23-5/8	16'-6"	14'-1-3/8"	4	4		
103'	14'	GLCSLX-FS-500-15 (S or AL)-94-14	Steel	30'	54	13-1/8	20-7/8	28-3/8	12-3/4	7-1/8	23-5/8	16'-6"	16'-1-3/8"	4	4		
	10'	GLCS-FS-500-15 (S or AL)-103-10	Steel	20'	54	13-1/8	16-1/2	24	12-3/4	7-1/8	23-5/8	16'-4"	11'-9"	3	6		
	10'	AL-FS-500-15-23-10	Alum	20'	54	13-1/4	23-7/8	-	12-5/8	7-1/4	23-5/8	16'-4"	12'-4-3/8"	3	6		
	12'	GLCSL-FS-500-15 (S or AL)-103-10	Steel	25'	54	13-1/8	18-7/8	26-3/8	12-3/4	7-1/8	23-5/8	16'-4"	11'-11-3/8"	3	5		
103'	12'	GLCS-FS-500-15 (S or AL)-103-12	Steel	20'	54	13-1/8	16-1/2	24	12-3/4	7-1/8	23-5/8	16'-6"	13'-9"	4	6		
	12'	AL-FS-500-15-23-12	Alum	20'	54	13-1/4	23-7/8	-	12-5/8	7-1/4	23-5/8	16'-6"	14'-4-3/8"	4	6		
	14'	GLCSL-FS-500-15 (S or AL)-103-12	Steel	25'	54	13-1/8	18-7/8	26-3/8	12-3/4	7-1/8	23-5/8	16'-6"	13'-11-3/8"	4	5		
	14'	GLCS-FS-500-15 (S or AL)-103-14	Steel	20'	54	13-1/8	16-1/2	24	12-3/4	7-1/8	23-5/8	16'-6"	15'-9"	4	6		
124'	14'	AL-FS-500-15-23-14	Alum	20'	54	13-1/4	23-7/8	-	12-5/8	7-1/4	23-5/8	16'-6"	16'-4-3/8"	4	6		
	10'	GLCSLX-FS-500-15 (S or AL)-103-14	Steel	25'	54	13-1/8	18-7/8	26-3/8	12-3/4	7-1/8	23-5/8	16'-6"	15'-11-3/8"	4	5		
	10'	GLCSLX-FS-500-15 (S or AL)-124-10	Steel	30'	54	13-1/8	20-7/8	28-3/8	12-3/4	7-1/8	23-5/8	16'-4"	12'-1-3/8"	3	5		
	12'	GLCSLX-FS-500-15 (S or AL)-124-12	Steel	30'	54	13-1/8	20-7/8	28-3/8	12-3/4	7-1/8	23-5/8	16'-6"	14'-1-3/8"	4	5		
14'	GLCSLX-FS-500-15 (S or AL)-124-14	Steel	30'	54	13-1/8	20-7/8	28-3/8	12-3/4	7-1/8	23-5/8	16'-6"	16'-1-3/8"	4	5			

*This column provides the total number of support assemblies based on the "L1" dimensions shown. Support assemblies are designed to AISC specifications and do not require bracing. If no movement of the support assembly is preferred, then bracing to the building steel is recommended (not included).
To Determine Hook Coverage: [Bridge Travel on Runway = Runway Length - (2xL8)] by [Hoist Trolley Travel on Bridge = Bridge Length - L3 - L6] (L6 allows for festoon stack-up).
Gorbel Free Standing Work Station Bridge Crane kits include: bridge, runways, the appropriate number of support assemblies, hoist trolley, end trucks, end stops, flat wire festooning, festoon gliders (festoon trolleys on steel runway lengths greater than 63' and all aluminum systems), festoon stack-up section, splice joints and hanger brackets. Hoist and anchor bolts provided by others.
 Dimensions are for reference only and are subject to change without notice.

FREE STANDING WORK STATION BRIDGE CRANE

BRIDGE LENGTH (L)	RUNWAY LENGTH	TS	MODEL NUMBER	TRACK MAT.	RUNWAY			BRIDGE					SUPPORT STRUCTURE			
					MAX. L1	L7 in	L8 in	H3 in	H3A in	H4 in	L3 in	L6 in	OAW	OAH	D in	W
20'	23'	10'	GLCS-FS-500-20 (S or AL)-23-10	Steel	20'	9	13-1/8	16-1/2	24	12-3/4	7-1/8	21-3/4	21'-4"	11'-9"	3	2
		10'	AL-FS-500-20-23-10	Alum	20'	13	13-1/4	23-7/8	-	12-5/8	7-1/4	27	21'-4"	12'-4-3/8"	3	2
		12'	GLCS-FS-500-20 (S or AL)-23-12	Steel	20'	9	13-1/8	16-1/2	24	12-3/4	7-1/8	21-3/4	21'-6"	13'-9"	4	2
		12'	AL-FS-500-20-23-12	Alum	20'	13	13-1/4	23-7/8	-	12-5/8	7-1/4	27	21'-6"	14'-4-3/8"	4	2
	14'	GLCS-FS-500-20 (S or AL)-23-14	Steel	20'	9	13-1/8	16-1/2	24	12-3/4	7-1/8	21-3/4	21'-6"	15'-9"	4	2	
	14'	AL-FS-500-20-23-14	Alum	20'	13	13-1/4	23-7/8	-	12-5/8	7-1/4	27	21'-6"	16'-4-3/8"	4	2	
	28'	10'	GLCSL-FS-500-20 (S or AL)-28-10	Steel	25'	9	13-1/8	18-7/8	26-3/8	12-3/4	7-1/8	21-3/4	21'-4"	11'-11-3/8"	3	2
		12'	GLCSL-FS-500-20 (S or AL)-28-12	Steel	25'	9	13-1/8	18-7/8	26-3/8	12-3/4	7-1/8	21-3/4	21'-6"	13'-11-3/8"	4	2
		14'	GLCSL-FS-500-20 (S or AL)-28-14	Steel	25'	9	13-1/8	18-7/8	26-3/8	12-3/4	7-1/8	21-3/4	21'-6"	15'-11-3/8"	4	2
	33'	10'	GLCS-FS-500-20 (S or AL)-33-10	Steel	20'	9	13-1/8	16-1/2	24	12-3/4	7-1/8	21-3/4	21'-4"	11'-9"	3	3
		10'	AL-FS-500-20-33-10	Alum	20'	19	13-1/4	23-7/8	-	12-5/8	7-1/4	27	21'-4"	12'-4-3/8"	3	3
		12'	GLCS-FS-500-20 (S or AL)-33-12	Steel	20'	9	13-1/8	16-1/2	24	12-3/4	7-1/8	21-3/4	21'-6"	13'-9"	4	3
12'		AL-FS-500-20-33-12	Alum	20'	19	13-1/4	23-7/8	-	12-5/8	7-1/4	27	21'-6"	14'-4-3/8"	4	3	
14'	GLCS-FS-500-20 (S or AL)-33-14	Steel	20'	9	13-1/8	16-1/2	24	12-3/4	7-1/8	21-3/4	21'-6"	15'-9"	4	3		
14'	AL-FS-500-20-33-14	Alum	20'	19	13-1/4	23-7/8	-	12-5/8	7-1/4	27	21'-6"	16'-4-3/8"	4	3		
34'	10'	GLCSLX-FS-500-20 (S or AL)-34-10	Steel	30'	9	13-1/8	20-7/8	28-3/8	12-3/4	7-1/8	21-3/4	21'-4"	12'-1-3/8"	3	2	
	12'	GLCSLX-FS-500-20 (S or AL)-34-12	Steel	30'	9	13-1/8	20-7/8	28-3/8	12-3/4	7-1/8	21-3/4	21'-6"	14'-1-3/8"	4	2	
	14'	GLCSLX-FS-500-20 (S or AL)-34-14	Steel	30'	9	13-1/8	20-7/8	28-3/8	12-3/4	7-1/8	21-3/4	21'-6"	16'-1-3/8"	4	2	
43'	10'	GLCS-FS-500-20 (S or AL)-43-10	Steel	20'	13	13-1/8	16-1/2	24	12-3/4	7-1/8	21-3/4	21'-4"	11'-9"	3	3	
	10'	AL-FS-500-20-43-10	Alum	20'	26	13-1/4	23-7/8	-	12-5/8	7-1/4	27	21'-4"	12'-4-3/8"	3	3	
	12'	GLCS-FS-500-20 (S or AL)-43-12	Steel	20'	13	13-1/8	16-1/2	24	12-3/4	7-1/8	21-3/4	21'-6"	13'-9"	4	3	
	12'	AL-FS-500-20-43-12	Alum	20'	26	13-1/4	23-7/8	-	12-5/8	7-1/4	27	21'-6"	14'-4-3/8"	4	3	
14'	GLCS-FS-500-20 (S or AL)-43-14	Steel	20'	13	13-1/8	16-1/2	24	12-3/4	7-1/8	21-3/4	21'-6"	15'-9"	4	3		
14'	AL-FS-500-20-43-14	Alum	20'	26	13-1/4	23-7/8	-	12-5/8	7-1/4	27	21'-6"	16'-4-3/8"	4	3		
53'	10'	GLCS-FS-500-20 (S or AL)-53-10	Steel	20'	13	13-1/8	16-1/2	24	12-3/4	7-1/8	21-3/4	21'-4"	11'-9"	3	4	
	10'	AL-FS-500-20-53-10	Alum	20'	30	13-1/4	23-7/8	-	12-5/8	7-1/4	27	21'-4"	12'-4-3/8"	3	4	
	12'	GLCSL-FS-500-20 (S or AL)-53-12	Steel	25'	13	13-1/8	18-7/8	26-3/8	12-3/4	7-1/8	21-3/4	21'-4"	11'-11-3/8"	3	3	
	12'	AL-FS-500-20-53-12	Alum	20'	30	13-1/8	16-1/2	24	12-3/4	7-1/8	21-3/4	21'-6"	13'-9"	4	3	
	12'	GLCSL-FS-500-20 (S or AL)-53-12	Steel	25'	13	13-1/8	18-7/8	26-3/8	12-3/4	7-1/8	21-3/4	21'-6"	14'-4-3/8"	4	4	
	12'	AL-FS-500-20-53-12	Alum	20'	30	13-1/4	23-7/8	-	12-5/8	7-1/4	27	21'-6"	15'-9"	4	4	
14'	GLCS-FS-500-20 (S or AL)-53-14	Steel	20'	13	13-1/8	16-1/2	24	12-3/4	7-1/8	21-3/4	21'-6"	15'-9"	4	4		
14'	AL-FS-500-20-53-14	Alum	20'	30	13-1/4	23-7/8	-	12-5/8	7-1/4	27	21'-6"	16'-4-3/8"	4	4		
14'	GLCSL-FS-500-20 (S or AL)-53-14	Steel	25'	13	13-1/8	18-7/8	26-3/8	12-3/4	7-1/8	21-3/4	21'-6"	15'-11-3/8"	4	3		
63'	10'	GLCS-FS-500-20 (S or AL)-63-10	Steel	20'	19	13-1/8	16-1/2	24	12-3/4	7-1/8	21-3/4	21'-4"	11'-9"	3	4	
	10'	AL-FS-500-20-63-10	Alum	20'	36	13-1/4	23-7/8	-	12-5/8	7-1/4	27	21'-4"	12'-4-3/8"	3	4	
	12'	GLCS-FS-500-20 (S or AL)-63-12	Steel	20'	19	13-1/8	16-1/2	24	12-3/4	7-1/8	21-3/4	21'-6"	13'-9"	4	4	
	12'	AL-FS-500-20-63-12	Alum	20'	36	13-1/4	23-7/8	-	12-5/8	7-1/4	27	21'-6"	14'-4-3/8"	4	4	
14'	GLCS-FS-500-20 (S or AL)-63-14	Steel	20'	19	13-1/8	16-1/2	24	12-3/4	7-1/8	21-3/4	21'-6"	15'-9"	4	4		
14'	AL-FS-500-20-63-14	Alum	20'	36	13-1/4	23-7/8	-	12-5/8	7-1/4	27	21'-6"	16'-4-3/8"	4	4		
64'	10'	GLCSLX-FS-500-20 (S or AL)-64-10	Steel	30'	36	13-1/8	20-7/8	28-3/8	12-3/4	7-1/8	27	21'-4"	12'-1-3/8"	3	3	
	12'	GLCSLX-FS-500-20 (S or AL)-64-12	Steel	30'	36	13-1/8	20-7/8	28-3/8	12-3/4	7-1/8	27	21'-6"	14'-1-3/8"	4	3	
	14'	GLCSLX-FS-500-20 (S or AL)-64-14	Steel	30'	36	13-1/8	20-7/8	28-3/8	12-3/4	7-1/8	27	21'-6"	16'-1-3/8"	4	3	
78'	10'	GLCSL-FS-500-20 (S or AL)-78-10	Steel	25'	46	13-1/8	18-7/8	26-3/8	12-3/4	7-1/8	27	21'-4"	11'-11-3/8"	3	4	
	12'	GLCSL-FS-500-20 (S or AL)-78-12	Steel	25'	46	13-1/8	18-7/8	26-3/8	12-3/4	7-1/8	27	21'-6"	13'-11-3/8"	4	4	
	14'	GLCSL-FS-500-20 (S or AL)-78-14	Steel	25'	46	13-1/8	18-7/8	26-3/8	12-3/4	7-1/8	27	21'-6"	15'-11-3/8"	4	4	
83'	10'	GLCS-FS-500-20 (S or AL)-83-10	Steel	20'	46	13-1/8	16-1/2	24	12-3/4	7-1/8	27	21'-4"	11'-9"	3	5	
	10'	AL-FS-500-20-83-10	Alum	20'	46	13-1/4	23-7/8	-	12-5/8	7-1/4	27	21'-4"	12'-4-3/8"	3	5	
	12'	GLCS-FS-500-20 (S or AL)-83-12	Steel	20'	46	13-1/8	16-1/2	24	12-3/4	7-1/8	27	21'-6"	13'-9"	4	5	
	12'	AL-FS-500-20-83-12	Alum	20'	46	13-1/4	23-7/8	-	12-5/8	7-1/4	27	21'-6"	14'-4-3/8"	4	5	
14'	GLCS-FS-500-20 (S or AL)-83-14	Steel	20'	46	13-1/8	16-1/2	24	12-3/4	7-1/8	27	21'-6"	15'-9"	4	5		
14'	AL-FS-500-20-83-14	Alum	20'	46	13-1/4	23-7/8	-	12-5/8	7-1/4	27	21'-6"	16'-4-3/8"	4	5		
94'	10'	GLCSLX-FS-500-20 (S or AL)-94-10	Steel	30'	54	13-1/8	20-7/8	28-3/8	12-3/4	7-1/8	27	21'-4"	12'-1-3/8"	3	4	
	12'	GLCSLX-FS-500-20 (S or AL)-94-12	Steel	30'	54	13-1/8	20-7/8	28-3/8	12-3/4	7-1/8	27	21'-6"	14'-1-3/8"	4	4	
	14'	GLCSLX-FS-500-20 (S or AL)-94-14	Steel	30'	54	13-1/8	20-7/8	28-3/8	12-3/4	7-1/8	27	21'-6"	16'-1-3/8"	4	4	
103'	10'	GLCS-FS-500-20 (S or AL)-103-10	Steel	20'	54	13-1/8	16-1/2	24	12-3/4	7-1/8	27	21'-4"	11'-9"	3	6	
	10'	AL-FS-500-20-103-10	Alum	20'	54	13-1/4	23-7/8	-	12-5/8	7-1/4	27	21'-4"	12'-4-3/8"	3	6	
	12'	GLCSL-FS-500-20 (S or AL)-103-12	Steel	25'	54	13-1/8	18-7/8	26-3/8	12-3/4	7-1/8	27	21'-4"	11'-11-3/8"	3	5	
	12'	AL-FS-500-20-103-12	Alum	20'	54	13-1/8	16-1/2	24	12-3/4	7-1/8	27	21'-6"	13'-9"	4	6	
	12'	GLCSL-FS-500-20 (S or AL)-103-12	Steel	25'	54	13-1/8	18-7/8	26-3/8	12-3/4	7-1/8	27	21'-6"	14'-4-3/8"	4	6	
	12'	AL-FS-500-20-103-12	Alum	20'	54	13-1/4	23-7/8	-	12-5/8	7-1/4	27	21'-6"	15'-9"	4	6	
14'	GLCS-FS-500-20 (S or AL)-103-14	Steel	20'	54	13-1/8	16-1/2	24	12-3/4	7-1/8	27	21'-6"	15'-9"	4	6		
14'	AL-FS-500-20-103-14	Alum	20'	54	13-1/4	23-7/8	-	12-5/8	7-1/4	27	21'-6"	16'-4-3/8"	4	6		
14'	GLCSL-FS-500-20 (S or AL)-103-14	Steel	25'	54	13-1/8	18-7/8	26-3/8	12-3/4	7-1/8	27	21'-6"	15'-11-3/8"	4	5		
124'	10'	GLCSLX-FS-500-20 (S or AL)-124-10	Steel	30'	54	13-1/8	20-7/8	28-3/8	12-3/4	7-1/8	27	21'-4"	12'-1-3/8"	3	5	
	12'	GLCSLX-FS-500-20 (S or AL)-124-12	Steel	30'	54	13-1/8	20-7/8	28-3/8	12-3/4	7-1/8	27	21'-6"	14'-1-3/8"	4	5	
	14'	GLCSLX-FS-500-20 (S or AL)-124-14	Steel	30'	54	13-1/8	20-7/8	28-3/8	12-3/4	7-1/8	27	21'-6"	16'-1-3/8"	4	5	

*This column provides the total number of support assemblies based on the "L1" dimensions shown. Support assemblies are designed to AISC specifications and do not require bracing. If no movement of the support assembly is preferred, then bracing to the building steel is recommended (not included).

To Determine Hook Coverage: [Bridge Travel on Runway = Runway Length - (2xL8)] by [Hoist Trolley Travel on Bridge = Bridge Length - L3 - L6] (L6 allows for festoon stack-up).

Gorbel Free Standing Work Station Bridge Cranes include: bridge, runways, the appropriate number of support assemblies, hoist trolley, end trucks, end stops, flat wire festooning, festoon gliders (festoon trolleys on steel runway lengths greater than 63' and all aluminum systems), festoon stack-up section, splice joints and hanger brackets. Hoist and anchor bolts provided by others. Dimensions are for reference only and are subject to change without notice.

FREE STANDING WORK STATION BRIDGE CRANES

BRIDGE LENGTH (L)	RUNWAY LENGTH	TS	MODEL NUMBER	TRACK MAT.	RUNWAY			BRIDGE				SUPPORT STRUCTURE				
					MAX. L1	L7 in	L8 in	H3 in	H3A in	H4 in	L3 in	L6 in	OAW	OAH	D in	LDs
23'	10'		GLCS-FS-500-23 (S or AL)-23-10	Steel	20'	9	13-1/8	16-1/2	24	12-3/4	7-1/8	21-3/4	24'-4"	11'-9"	3	2
			AL-FS-500-23-23-10	Alum.	20'	13	13-1/4	23-7/8	-	12-5/8	7-1/4	30-3/8	24'-4"	12'-4-3/8"	3	2
			GLCS-FS-500-23 (S or AL)-23-12	Steel	20'	9	13-1/8	16-1/2	24	12-3/4	7-1/8	21-3/4	24'-6"	13'-9"	4	2
			AL-FS-500-23-23-12	Alum.	20'	13	13-1/4	23-7/8	-	12-5/8	7-1/4	30-3/8	24'-6"	14'-4-3/8"	4	2
	12'		GLCS-FS-500-23 (S or AL)-23-14	Steel	20'	9	13-1/8	16-1/2	24	12-3/4	7-1/8	21-3/4	24'-6"	15'-9"	4	2
			AL-FS-500-23-23-14	Alum.	20'	13	13-1/4	23-7/8	-	12-5/8	7-1/4	30-3/8	24'-6"	16'-4-3/8"	4	2
			GLCSL-FS-500-23 (S or AL)-28-10	Steel	25'	9	13-1/8	18-7/8	26-3/8	12-3/4	7-1/8	21-3/4	24'-4"	11'-11-3/8"	3	2
			GLCSL-FS-500-23 (S or AL)-28-12	Steel	25'	9	13-1/8	18-7/8	26-3/8	12-3/4	7-1/8	21-3/4	24'-6"	13'-11-3/8"	4	2
	14'		GLCSL-FS-500-23 (S or AL)-28-14	Steel	25'	9	13-1/8	18-7/8	26-3/8	12-3/4	7-1/8	21-3/4	24'-6"	15'-11-3/8"	4	2
			AL-FS-500-23-23-14	Alum.	20'	13	13-1/4	23-7/8	-	12-5/8	7-1/4	30-3/8	24'-6"	16'-4-3/8"	4	2
			GLCS-FS-500-23 (S or AL)-33-10	Steel	20'	9	13-1/8	16-1/2	24	12-3/4	7-1/8	21-3/4	24'-4"	11'-9"	3	3
			AL-FS-500-23-33-10	Alum.	20'	19	13-1/4	23-7/8	-	12-5/8	7-1/4	30-3/8	24'-4"	12'-4-3/8"	3	3
12'		GLCS-FS-500-23 (S or AL)-33-12	Steel	20'	9	13-1/8	16-1/2	24	12-3/4	7-1/8	21-3/4	24'-6"	13'-9"	4	3	
		AL-FS-500-23-33-12	Alum.	20'	19	13-1/4	23-7/8	-	12-5/8	7-1/4	30-3/8	24'-6"	14'-4-3/8"	4	3	
		GLCS-FS-500-23 (S or AL)-33-14	Steel	20'	9	13-1/8	16-1/2	24	12-3/4	7-1/8	21-3/4	24'-6"	15'-9"	4	3	
		AL-FS-500-23-33-14	Alum.	20'	19	13-1/4	23-7/8	-	12-5/8	7-1/4	30-3/8	24'-6"	16'-4-3/8"	4	3	
34'		GLCSLX-FS-500-23 (S or AL)-34-10	Steel	30'	9	13-1/8	20-7/8	28-3/8	12-3/4	7-1/8	21-3/4	24'-4"	12'-1-3/8"	3	2	
		GLCSLX-FS-500-23 (S or AL)-34-12	Steel	30'	9	13-1/8	20-7/8	28-3/8	12-3/4	7-1/8	21-3/4	24'-6"	14'-1-3/8"	4	2	
		GLCSLX-FS-500-23 (S or AL)-34-14	Steel	30'	9	13-1/8	20-7/8	28-3/8	12-3/4	7-1/8	21-3/4	24'-6"	16'-1-3/8"	4	2	
		AL-FS-500-23-43-10	Alum.	20'	26	13-1/4	23-7/8	-	12-5/8	7-1/4	30-3/8	24'-4"	12'-4-3/8"	3	3	
43'		GLCS-FS-500-23 (S or AL)-43-10	Steel	20'	13	13-1/8	16-1/2	24	12-3/4	7-1/8	21-3/4	24'-4"	11'-9"	3	3	
		AL-FS-500-23-43-10	Alum.	20'	26	13-1/4	23-7/8	-	12-5/8	7-1/4	30-3/8	24'-4"	12'-4-3/8"	3	3	
		GLCS-FS-500-23 (S or AL)-43-12	Steel	20'	13	13-1/8	16-1/2	24	12-3/4	7-1/8	21-3/4	24'-6"	13'-9"	4	3	
		AL-FS-500-23-43-12	Alum.	20'	26	13-1/4	23-7/8	-	12-5/8	7-1/4	30-3/8	24'-6"	14'-4-3/8"	4	3	
12'		GLCS-FS-500-23 (S or AL)-43-14	Steel	20'	13	13-1/8	16-1/2	24	12-3/4	7-1/8	21-3/4	24'-6"	15'-9"	4	3	
		AL-FS-500-23-43-14	Alum.	20'	26	13-1/4	23-7/8	-	12-5/8	7-1/4	30-3/8	24'-6"	16'-4-3/8"	4	3	
		GLCS-FS-500-23 (S or AL)-53-10	Steel	20'	13	13-1/8	16-1/2	24	12-3/4	7-1/8	21-3/4	24'-4"	11'-9"	3	4	
		AL-FS-500-23-53-10	Alum.	20'	30	13-1/4	23-7/8	-	12-5/8	7-1/4	30-3/8	24'-4"	12'-4-3/8"	3	4	
10'		GLCSL-FS-500-23 (S or AL)-53-10	Steel	25'	13	13-1/8	18-7/8	26-3/8	12-3/4	7-1/8	21-3/4	24'-4"	11'-11-3/8"	3	3	
		GLCSL-FS-500-23 (S or AL)-53-12	Steel	20'	13	13-1/8	16-1/2	24	12-3/4	7-1/8	21-3/4	24'-6"	13'-9"	4	4	
		AL-FS-500-23-53-12	Alum.	20'	30	13-1/4	23-7/8	-	12-5/8	7-1/4	30-3/8	24'-6"	14'-4-3/8"	4	4	
		GLCSL-FS-500-23 (S or AL)-53-12	Steel	25'	13	13-1/8	18-7/8	26-3/8	12-3/4	7-1/8	21-3/4	24'-6"	13'-11-3/8"	4	3	
12'		GLCS-FS-500-23 (S or AL)-53-14	Steel	20'	13	13-1/8	16-1/2	24	12-3/4	7-1/8	21-3/4	24'-6"	15'-9"	4	4	
		AL-FS-500-23-53-14	Alum.	20'	30	13-1/4	23-7/8	-	12-5/8	7-1/4	30-3/8	24'-6"	16'-4-3/8"	4	4	
		GLCSL-FS-500-23 (S or AL)-53-14	Steel	25'	13	13-1/8	18-7/8	26-3/8	12-3/4	7-1/8	21-3/4	24'-6"	15'-11-3/8"	4	3	
		AL-FS-500-23-63-10	Alum.	20'	36	13-1/4	23-7/8	-	12-5/8	7-1/4	30-3/8	24'-4"	12'-4-3/8"	3	4	
63'		GLCS-FS-500-23 (S or AL)-63-10	Steel	20'	19	13-1/8	16-1/2	24	12-3/4	7-1/8	21-3/4	24'-6"	13'-9"	4	4	
		AL-FS-500-23-63-10	Alum.	20'	36	13-1/4	23-7/8	-	12-5/8	7-1/4	30-3/8	24'-6"	14'-4-3/8"	4	4	
		GLCS-FS-500-23 (S or AL)-63-12	Steel	20'	19	13-1/8	16-1/2	24	12-3/4	7-1/8	21-3/4	24'-6"	15'-9"	4	4	
		AL-FS-500-23-63-12	Alum.	20'	36	13-1/4	23-7/8	-	12-5/8	7-1/4	30-3/8	24'-6"	16'-4-3/8"	4	4	
14'		GLCS-FS-500-23 (S or AL)-63-14	Steel	20'	19	13-1/8	16-1/2	24	12-3/4	7-1/8	21-3/4	24'-6"	15'-9"	4	4	
		AL-FS-500-23-63-14	Alum.	20'	36	13-1/4	23-7/8	-	12-5/8	7-1/4	30-3/8	24'-6"	16'-4-3/8"	4	4	
		GLCSLX-FS-500-23 (S or AL)-64-10	Steel	30'	36	13-1/8	20-7/8	28-3/8	12-3/4	7-1/8	30-3/8	24'-4"	12'-1-3/8"	3	3	
		GLCSLX-FS-500-23 (S or AL)-64-12	Steel	30'	36	13-1/8	20-7/8	28-3/8	12-3/4	7-1/8	30-3/8	24'-6"	14'-1-3/8"	4	3	
14'		GLCSLX-FS-500-23 (S or AL)-64-14	Steel	30'	36	13-1/8	20-7/8	28-3/8	12-3/4	7-1/8	30-3/8	24'-6"	16'-1-3/8"	4	3	
		GLCSL-FS-500-23 (S or AL)-78-10	Steel	25'	46	13-1/8	18-7/8	26-3/8	12-3/4	7-1/8	30-3/8	24'-4"	11'-11-3/8"	3	4	
		GLCSL-FS-500-23 (S or AL)-78-12	Steel	25'	46	13-1/8	18-7/8	26-3/8	12-3/4	7-1/8	30-3/8	24'-6"	13'-11-3/8"	4	4	
		GLCSL-FS-500-23 (S or AL)-78-14	Steel	25'	46	13-1/8	18-7/8	26-3/8	12-3/4	7-1/8	30-3/8	24'-6"	15'-11-3/8"	4	4	
83'		GLCS-FS-500-23 (S or AL)-83-10	Steel	20'	46	13-1/8	16-1/2	24	12-3/4	7-1/8	30-3/8	24'-4"	11'-9"	3	5	
		AL-FS-500-23-83-10	Alum.	20'	46	13-1/4	23-7/8	-	12-5/8	7-1/4	30-3/8	24'-4"	12'-4-3/8"	3	5	
		GLCS-FS-500-23 (S or AL)-83-12	Steel	20'	46	13-1/8	16-1/2	24	12-3/4	7-1/8	30-3/8	24'-6"	13'-9"	4	5	
		AL-FS-500-23-83-12	Alum.	20'	46	13-1/4	23-7/8	-	12-5/8	7-1/4	30-3/8	24'-6"	14'-4-3/8"	4	5	
14'		GLCS-FS-500-23 (S or AL)-83-14	Steel	20'	46	13-1/8	16-1/2	24	12-3/4	7-1/8	30-3/8	24'-6"	15'-9"	4	5	
		AL-FS-500-23-83-14	Alum.	20'	46	13-1/4	23-7/8	-	12-5/8	7-1/4	30-3/8	24'-6"	16'-4-3/8"	4	5	
		GLCSLX-FS-500-23 (S or AL)-94-10	Steel	30'	54	13-1/8	20-7/8	28-3/8	12-3/4	7-1/8	30-3/8	24'-4"	12'-1-3/8"	3	4	
		GLCSLX-FS-500-23 (S or AL)-94-12	Steel	30'	54	13-1/8	20-7/8	28-3/8	12-3/4	7-1/8	30-3/8	24'-6"	14'-1-3/8"	4	4	
14'		GLCSLX-FS-500-23 (S or AL)-94-14	Steel	30'	54	13-1/8	20-7/8	28-3/8	12-3/4	7-1/8	30-3/8	24'-6"	16'-1-3/8"	4	4	
		AL-FS-500-23-103-10	Alum.	20'	54	13-1/8	16-1/2	24	12-3/4	7-1/8	30-3/8	24'-4"	11'-9"	3	6	
		AL-FS-500-23-103-10	Alum.	20'	54	13-1/4	23-7/8	-	12-5/8	7-1/4	30-3/8	24'-4"	12'-4-3/8"	3	6	
		GLCSL-FS-500-23 (S or AL)-103-10	Steel	25'	54	13-1/8	18-7/8	26-3/8	12-3/4	7-1/8	30-3/8	24'-4"	11'-11-3/8"	3	5	
12'		GLCS-FS-500-23 (S or AL)-103-12	Steel	20'	54	13-1/8	16-1/2	24	12-3/4	7-1/8	30-3/8	24'-6"	13'-9"	4	6	
		AL-FS-500-23-103-12	Alum.	20'	54	13-1/4	23-7/8	-	12-5/8	7-1/4	30-3/8	24'-6"	14'-4-3/8"	4	6	
		GLCSL-FS-500-23 (S or AL)-103-12	Steel	25'	54	13-1/8	18-7/8	26-3/8	12-3/4	7-1/8	30-3/8	24'-6"	13'-11-3/8"	4	5	
		GLCS-FS-500-23 (S or AL)-103-14	Steel	20'	54	13-1/8	16-1/2	24	12-3/4	7-1/8	30-3/8	24'-6"	15'-9"	4	6	
14'		AL-FS-500-23-103-14	Alum.	20'	54	13-1/4	23-7/8	-	12-5/8	7-1/4	30-3/8	24'-6"	16'-4-3/8"	4	6	
		GLCSL-FS-500-23 (S or AL)-103-14	Steel	25'	54	13-1/8	18-7/8	26-3/8	12-3/4	7-1/8	30-3/8	24'-6"	15'-11-3/8"	4	5	
		GLCSLX-FS-500-23 (S or AL)-124-10	Steel	30'	54	13-1/8	20-7/8	28-3/8	12-3/4	7-1/8	30-3/8	24'-4"	12'-1-3/8"	3	5	
		GLCSLX-FS-500-23 (S or AL)-124-12	Steel	30'	54	13-1/8	20-7/8	28-3/8	12-3/4	7-1/8	30-3/8	24'-6"	14'-1-3/8"	4	5	
14'		GLCSLX-FS-500-23 (S or AL)-124-14	Steel	30'	54	13-1/8	20-7/8	28-3/8	12-3/4	7-1/8	30-3/8	24'-6"	16'-1-3/8"	4	5	

*This column provides the total number of support assemblies based on the "L1" dimensions shown. Support assemblies are designed to AISC specifications and do not require bracing. If no movement of the support assembly is preferred, then bracing to the building steel is recommended (not included).
To Determine Hook Coverage: [Bridge Travel on Runway = Runway Length - (2xL8)] by [Hoist Trolley Travel on Bridge = Bridge Length - L3 - L6] (L6 allows for festoon stack-up).
Gorbel Free Standing Work Station Bridge Crane kits include: bridge, runways, the appropriate number of support assemblies, hoist trolley, end trucks, end stops, flat wire festooning, festoon gliders (festoon trolleys on steel runway lengths greater than 63' and all aluminum systems), festoon stack-up section, splice joints and hanger brackets. Hoist and anchor bolts provided by others.
Dimensions are for reference only and are subject to change without notice.

FREE STANDING WORK STATION BRIDGE CRANE

BRIDGE LENGTH (L)	RUNWAY LENGTH	TS	MODEL NUMBER	TRACK MAT.	RUNWAY			BRIDGE				SUPPORT				
					MAX. L1	L7 in	L8 in	H3 in	H3A in	H4 in	L3 in	L6 in	OAW	OAH	D in	Leg
28'	23'	10'	GLCS-FS-500-28 (S or AL)-23-10	Steel	20'	9	23-1/4	18-3/8	22-5/8	15-1/8	7-1/8	31-1/4	29'-4"	11'-11-7/8"	3	2
		10'	AL-FS-500-28-23-10	Alum	20'	13	23-3/8	22-5/8	-	13-1/8	7-7/8	37-1/8	29'-4"	12'-4-1/8"	3	2
		12'	GLCS-FS-500-28 (S or AL)-23-12	Steel	20'	9	23-1/4	18-3/8	22-5/8	15-1/8	7-1/8	31-1/4	29'-6"	13'-11-7/8"	4	2
		12'	AL-FS-500-28-23-12	Alum	20'	13	23-3/8	22-5/8	-	13-1/8	7-7/8	37-1/8	29'-6"	14'-4-1/8"	4	2
	14'	GLCS-FS-500-28 (S or AL)-23-14	Steel	20'	9	23-1/4	18-3/8	22-5/8	15-1/8	7-1/8	31-1/4	29'-6"	15'-11-7/8"	4	2	
	14'	AL-FS-500-28-23-14	Alum	20'	13	23-3/8	22-5/8	-	13-1/8	7-7/8	37-1/8	29'-6"	16'-4-1/8"	4	2	
	10'	GLCSL-FS-500-28 (S or AL)-28-10	Steel	25'	9	23-1/4	20-3/4	25	15-1/8	7-1/8	31-1/4	29'-4"	12'-2-1/4"	3	2	
	12'	GLCSL-FS-500-28 (S or AL)-28-12	Steel	25'	9	23-1/4	20-3/4	25	15-1/8	7-1/8	31-1/4	29'-6"	14'-2-1/4"	4	2	
	14'	GLCSL-FS-500-28 (S or AL)-28-14	Steel	25'	9	23-1/4	20-3/4	25	15-1/8	7-1/8	31-1/4	29'-6"	16'-2-1/4"	4	2	
	10'	GLCS-FS-500-28 (S or AL)-33-10	Steel	20'	9	23-1/4	18-3/8	22-5/8	15-1/8	7-1/8	31-1/4	29'-4"	11'-11-7/8"	3	3	
	10'	AL-FS-500-28-33-10	Alum	20'	19	23-3/8	22-5/8	-	13-1/8	7-7/8	37-1/8	29'-4"	12'-4-1/8"	3	3	
	12'	GLCS-FS-500-28 (S or AL)-33-12	Steel	20'	9	23-1/4	18-3/8	22-5/8	15-1/8	7-1/8	31-1/4	29'-6"	13'-11-7/8"	4	3	
12'	AL-FS-500-28-33-12	Alum	20'	19	23-3/8	22-5/8	-	13-1/8	7-7/8	37-1/8	29'-6"	14'-4-1/8"	4	3		
14'	GLCS-FS-500-28 (S or AL)-33-14	Steel	20'	9	23-1/4	18-3/8	22-5/8	15-1/8	7-1/8	31-1/4	29'-6"	15'-11-7/8"	4	3		
14'	AL-FS-500-28-33-14	Alum	20'	19	23-3/8	22-5/8	-	13-1/8	7-7/8	37-1/8	29'-6"	16'-4-1/8"	4	3		
10'	GLCSLX-FS-500-28 (S or AL)-34-10	Steel	30'	9	23-1/4	22-3/4	27	15-1/8	7-1/8	31-1/4	29'-4"	12'-4-1/4"	3	2		
12'	GLCSLX-FS-500-28 (S or AL)-34-12	Steel	30'	9	23-1/4	22-3/4	27	15-1/8	7-1/8	31-1/4	29'-6"	14'-4-1/4"	4	2		
14'	GLCSLX-FS-500-28 (S or AL)-34-14	Steel	30'	9	23-1/4	22-3/4	27	15-1/8	7-1/8	31-1/4	29'-6"	16'-4-1/4"	4	2		
10'	GLCS-FS-500-28 (S or AL)-43-10	Steel	20'	13	23-1/4	18-3/8	22-5/8	15-1/8	7-1/8	31-1/4	29'-4"	11'-11-7/8"	3	3		
10'	AL-FS-500-28-43-10	Alum	20'	25	23-3/8	22-5/8	-	13-1/8	7-7/8	37-1/8	29'-4"	12'-4-1/8"	3	3		
12'	GLCS-FS-500-28 (S or AL)-43-12	Steel	20'	13	23-1/4	18-3/8	22-5/8	15-1/8	7-1/8	31-1/4	29'-6"	13'-11-7/8"	4	3		
12'	AL-FS-500-28-43-12	Alum	20'	25	23-3/8	22-5/8	-	13-1/8	7-7/8	37-1/8	29'-6"	14'-4-1/8"	4	3		
14'	GLCS-FS-500-28 (S or AL)-43-14	Steel	20'	13	23-1/4	18-3/8	22-5/8	15-1/8	7-1/8	31-1/4	29'-6"	15'-11-7/8"	4	3		
14'	AL-FS-500-28-43-14	Alum	20'	26	23-3/8	22-5/8	-	13-1/8	7-7/8	37-1/8	29'-6"	16'-4-1/8"	4	3		
10'	GLCS-FS-500-28 (S or AL)-53-10	Steel	20'	13	23-1/4	18-3/8	22-5/8	15-1/8	7-1/8	31-1/4	29'-4"	11'-11-7/8"	3	4		
10'	AL-FS-500-28-53-10	Alum	20'	30	23-3/8	22-5/8	-	13-1/8	7-7/8	37-1/8	29'-4"	12'-4-1/8"	3	4		
12'	GLCSL-FS-500-28 (S or AL)-53-10	Steel	25'	13	23-1/4	20-3/4	25	15-1/8	7-1/8	31-1/4	29'-4"	12'-2-1/4"	3	3		
12'	GLCSL-FS-500-28 (S or AL)-53-12	Steel	20'	13	23-1/4	18-3/8	22-5/8	15-1/8	7-1/8	31-1/4	29'-6"	13'-11-7/8"	4	4		
12'	AL-FS-500-28-53-12	Alum	20'	30	23-3/8	22-5/8	-	13-1/8	7-7/8	37-1/8	29'-6"	14'-4-1/8"	4	4		
12'	GLCSL-FS-500-28 (S or AL)-53-12	Steel	25'	13	23-1/4	20-3/4	25	15-1/8	7-1/8	31-1/4	29'-6"	14'-2-1/4"	4	3		
14'	GLCS-FS-500-28 (S or AL)-53-14	Steel	20'	13	23-1/4	18-3/8	22-5/8	15-1/8	7-1/8	31-1/4	29'-6"	15'-11-7/8"	4	4		
14'	AL-FS-500-28-53-14	Alum	20'	30	23-3/8	22-5/8	-	13-1/8	7-7/8	37-1/8	29'-6"	16'-4-1/8"	4	4		
14'	GLCSL-FS-500-28 (S or AL)-53-14	Steel	25'	13	23-1/4	20-3/4	25	15-1/8	7-1/8	31-1/4	29'-6"	16'-2-1/4"	4	3		
10'	GLCS-FS-500-28 (S or AL)-63-10	Steel	20'	19	23-1/4	18-3/8	22-5/8	15-1/8	7-1/8	31-1/4	29'-4"	11'-11-7/8"	3	4		
10'	AL-FS-500-28-63-10	Alum	20'	36	23-3/8	22-5/8	-	13-1/8	7-7/8	37-1/8	29'-4"	12'-4-1/8"	3	4		
12'	GLCS-FS-500-28 (S or AL)-63-12	Steel	20'	19	23-1/4	18-3/8	22-5/8	15-1/8	7-1/8	31-1/4	29'-6"	13'-11-7/8"	4	4		
12'	AL-FS-500-28-63-12	Alum	20'	36	23-3/8	22-5/8	-	13-1/8	7-7/8	37-1/8	29'-6"	14'-4-1/8"	4	4		
14'	GLCS-FS-500-28 (S or AL)-63-14	Steel	20'	19	23-1/4	18-3/8	22-5/8	15-1/8	7-1/8	31-1/4	29'-6"	15'-11-7/8"	4	4		
14'	AL-FS-500-28-63-14	Alum	20'	36	23-3/8	22-5/8	-	13-1/8	7-7/8	37-1/8	29'-6"	16'-4-1/8"	4	4		
10'	GLCSLX-FS-500-28 (S or AL)-64-10	Steel	30'	36	23-1/4	22-3/4	27	15-1/8	7-1/8	31-1/4	29'-4"	12'-4-1/4"	3	3		
12'	GLCSLX-FS-500-28 (S or AL)-64-12	Steel	30'	36	23-1/4	22-3/4	27	15-1/8	7-1/8	31-1/4	29'-6"	14'-4-1/4"	4	3		
14'	GLCSLX-FS-500-28 (S or AL)-64-14	Steel	30'	36	23-1/4	22-3/4	27	15-1/8	7-1/8	31-1/4	29'-6"	16'-4-1/4"	4	3		
10'	GLCSL-FS-500-28 (S or AL)-78-10	Steel	25'	46	23-1/4	20-3/4	25	15-1/8	7-1/8	37-1/8	29'-4"	12'-2-1/4"	3	4		
12'	GLCSL-FS-500-28 (S or AL)-78-12	Steel	25'	46	23-1/4	20-3/4	25	15-1/8	7-1/8	37-1/8	29'-6"	14'-2-1/4"	4	4		
14'	GLCSL-FS-500-28 (S or AL)-78-14	Steel	25'	46	23-1/4	20-3/4	25	15-1/8	7-1/8	37-1/8	29'-6"	16'-2-1/4"	4	4		
10'	GLCS-FS-500-28 (S or AL)-83-10	Steel	20'	46	23-1/4	18-3/8	22-5/8	15-1/8	7-1/8	37-1/8	29'-4"	11'-11-7/8"	3	5		
10'	AL-FS-500-28-83-10	Alum	20'	46	23-3/8	22-5/8	-	13-1/8	7-7/8	37-1/8	29'-4"	12'-4-1/8"	3	5		
12'	GLCS-FS-500-28 (S or AL)-83-12	Steel	20'	46	23-1/4	18-3/8	22-5/8	15-1/8	7-1/8	37-1/8	29'-6"	13'-11-7/8"	4	5		
12'	AL-FS-500-28-83-12	Alum	20'	46	23-3/8	22-5/8	-	13-1/8	7-7/8	37-1/8	29'-6"	14'-4-1/8"	4	5		
14'	GLCS-FS-500-28 (S or AL)-83-14	Steel	20'	46	23-1/4	18-3/8	22-5/8	15-1/8	7-1/8	37-1/8	29'-6"	15'-11-7/8"	4	5		
14'	AL-FS-500-28-83-14	Alum	20'	46	23-3/8	22-5/8	-	13-1/8	7-7/8	37-1/8	29'-6"	16'-4-1/8"	4	5		
10'	GLCSLX-FS-500-28 (S or AL)-94-10	Steel	30'	54	23-1/4	22-3/4	27	15-1/8	7-1/8	37-1/8	29'-4"	12'-4-1/4"	3	4		
12'	GLCSLX-FS-500-28 (S or AL)-94-12	Steel	30'	54	23-1/4	22-3/4	27	15-1/8	7-1/8	37-1/8	29'-6"	14'-4-1/4"	4	4		
14'	GLCSLX-FS-500-28 (S or AL)-94-14	Steel	30'	54	23-1/4	22-3/4	27	15-1/8	7-1/8	37-1/8	29'-6"	16'-4-1/4"	4	4		
10'	GLCS-FS-500-28 (S or AL)-103-10	Steel	20'	54	23-1/4	18-3/8	22-5/8	15-1/8	7-1/8	37-1/8	29'-4"	11'-11-7/8"	3	6		
10'	AL-FS-500-28-103-10	Alum	20'	54	23-3/8	22-5/8	-	13-1/8	7-7/8	37-1/8	29'-4"	12'-4-1/8"	3	6		
12'	GLCSL-FS-500-28 (S or AL)-103-10	Steel	25'	54	23-1/4	20-3/4	25	15-1/8	7-1/8	37-1/8	29'-4"	12'-2-1/4"	3	5		
12'	GLCS-FS-500-28 (S or AL)-103-12	Steel	20'	54	23-1/4	18-3/8	22-5/8	15-1/8	7-1/8	37-1/8	29'-6"	13'-11-7/8"	4	6		
12'	AL-FS-500-28-103-12	Alum	20'	54	23-3/8	22-5/8	-	13-1/8	7-7/8	37-1/8	29'-6"	14'-4-1/8"	4	6		
12'	GLCSL-FS-500-28 (S or AL)-103-12	Steel	25'	54	23-1/4	20-3/4	25	15-1/8	7-1/8	37-1/8	29'-6"	14'-2-1/4"	4	5		
14'	GLCS-FS-500-28 (S or AL)-103-14	Steel	20'	54	23-1/4	18-3/8	22-5/8	15-1/8	7-1/8	37-1/8	29'-6"	15'-11-7/8"	4	6		
14'	AL-FS-500-28-103-14	Alum	20'	54	23-3/8	22-5/8	-	13-1/8	7-7/8	37-1/8	29'-6"	16'-4-1/8"	4	6		
14'	GLCSL-FS-500-28 (S or AL)-103-14	Steel	25'	54	23-1/4	20-3/4	25	15-1/8	7-1/8	37-1/8	29'-6"	16'-2-1/4"	4	5		
10'	GLCSLX-FS-500-28 (S or AL)-124-10	Steel	30'	54	23-1/4	22-3/4	27	15-1/8	7-1/8	37-1/8	29'-4"	12'-4-1/4"	3	5		
12'	GLCSLX-FS-500-28 (S or AL)-124-12	Steel	30'	54	23-1/4	22-3/4	27	15-1/8	7-1/8	37-1/8	29'-6"	14'-4-1/4"	4	5		
14'	GLCSLX-FS-500-28 (S or AL)-124-14	Steel	30'	54	23-1/4	22-3/4	27	15-1/8	7-1/8	37-1/8	29'-6"	16'-4-1/4"	4	5		

*This column provides the total number of support assemblies based on the "L1" dimensions shown. Support assemblies are designed to AISC specifications and do not require bracing. If no movement of the support assembly is preferred, then bracing to the building steel is recommended (not included).
To Determine Hook Coverage: [Bridge Travel on Runway = Runway Length - (2xL8)] by [Hoist Trolley Travel on Bridge = Bridge Length - L3 - L6] (L6 allows for festoon stack-up).
Goebel Free Standing Work Station Bridge Crane kits include: bridge, runways, the appropriate number of support assemblies, hoist trolley, end trucks, end stops, flat wire festooning, festoon gliders (festoon trolleys on steel runway lengths greater than 63' and all aluminum systems), festoon stack-up section, splice joints and hanger brackets. Hoist and anchor bolts provided by others.
Dimensions are for reference only and are subject to change without notice.

FREE STANDING WORK STATION BRIDGE CRANES

BRIDGE LENGTH (L)	RUNWAY LENGTH	TS	MODEL NUMBER	TRACK MAT.	RUNWAY			BRIDGE					SUPPORT STRUCTURE			
					MAX. L1	L7 in	L8 in	H3 in	H3A in	H4 in	L3 in	L6 in	OAW	OAH	D in	g
34'	28'	10'	GLCSL-FS-500-34 (S or AL)-28-10	Steel	25'	9	23-1/4	20-3/4	25	17-1/8	7-1/8	20-1/2	35'-6"	12'-3-1/4"	4	2
		12'	GLCSL-FS-500-34 (S or AL)-28-12	Steel	25'	9	23-1/4	20-3/4	25	17-1/8	7-1/8	20-1/2	35'-6"	14'-3-1/4"	4	2
		14'	GLCSL-FS-500-34 (S or AL)-28-14	Steel	25'	9	23-1/4	20-3/4	25	17-1/8	7-1/8	20-1/2	35'-6"	16'-3-1/4"	4	2
	33'	10'	GLCS-FS-500-34 (S or AL)-33-10	Steel	20'	9	23-1/4	20-3/8	22-5/8	17-1/8	7-1/8	20-1/2	35'-6"	12'-2-7/8"	4	3
		10'	AL-FS-500-34-33-10	Alum	20'	19	23-3/8	22-5/8	-	15-1/4	7-7/8	43-7/8	35'-6"	12'-5-1/8"	4	3
		12'	GLCS-FS-500-34 (S or AL)-33-12	Steel	20'	9	23-1/4	20-3/8	22-5/8	17-1/8	7-1/8	20-1/2	35'-6"	14'-2-7/8"	4	3
		12'	AL-FS-500-34-33-12	Alum	20'	19	23-3/8	22-5/8	-	15-1/4	7-7/8	43-7/8	35'-6"	14'-5-1/8"	4	3
	34'	10'	GLCSLX-FS-500-34 (S or AL)-34-10	Steel	30'	9	23-1/4	22-3/4	27	17-1/8	7-1/8	20-1/2	35'-6"	12'-5-1/4"	4	2
		12'	GLCSLX-FS-500-34 (S or AL)-34-12	Steel	30'	9	23-1/4	22-3/4	27	17-1/8	7-1/8	20-1/2	35'-6"	14'-5-1/4"	4	2
		14'	GLCSLX-FS-500-34 (S or AL)-34-14	Steel	30'	9	23-1/4	22-3/4	27	17-1/8	7-1/8	20-1/2	35'-6"	16'-5-1/4"	4	2
	43'	10'	GLCS-FS-500-34 (S or AL)-43-10	Steel	20'	13	23-1/4	20-3/8	22-5/8	17-1/8	7-1/8	20-1/2	35'-6"	12'-2-7/8"	4	3
		10'	AL-FS-500-34-43-10	Alum	20'	26	23-3/8	22-5/8	-	15-1/4	7-7/8	43-7/8	35'-6"	12'-5-1/8"	4	3
12'		GLCS-FS-500-34 (S or AL)-43-12	Steel	20'	13	23-1/4	20-3/8	22-5/8	17-1/8	7-1/8	20-1/2	35'-6"	14'-2-7/8"	4	3	
12'		AL-FS-500-34-43-12	Alum	20'	26	23-3/8	22-5/8	-	15-1/4	7-7/8	43-7/8	35'-6"	14'-5-1/8"	4	3	
53'	10'	GLCS-FS-500-34 (S or AL)-53-10	Steel	20'	13	23-1/4	20-3/8	22-5/8	17-1/8	7-1/8	20-1/2	35'-6"	12'-2-7/8"	4	4	
	10'	AL-FS-500-34-53-10	Alum	20'	30	23-3/8	22-5/8	-	15-1/4	7-7/8	43-7/8	35'-6"	12'-5-1/8"	4	4	
	10'	GLCSL-FS-500-34 (S or AL)-53-10	Steel	25'	13	23-1/4	20-3/4	25	17-1/8	7-1/8	20-1/2	35'-6"	14'-3-1/4"	4	3	
	12'	GLCS-FS-500-34 (S or AL)-53-12	Steel	20'	13	23-1/4	20-3/8	22-5/8	17-1/8	7-1/8	20-1/2	35'-6"	14'-2-7/8"	4	4	
63'	10'	AL-FS-500-34-53-12	Alum	20'	30	23-3/8	22-5/8	-	15-1/4	7-7/8	43-7/8	35'-6"	14'-5-1/8"	4	4	
	12'	GLCSL-FS-500-34 (S or AL)-53-12	Steel	25'	13	23-1/4	20-3/4	25	17-1/8	7-1/8	20-1/2	35'-6"	14'-3-1/4"	4	3	
	12'	GLCS-FS-500-34 (S or AL)-53-14	Steel	20'	13	23-1/4	20-3/8	22-5/8	17-1/8	7-1/8	20-1/2	35'-6"	16'-2-7/8"	4	4	
	14'	AL-FS-500-34-53-14	Alum	20'	30	23-3/8	22-5/8	-	15-1/4	7-7/8	43-7/8	35'-6"	16'-5-1/8"	4	4	
64'	10'	GLCSL-FS-500-34 (S or AL)-63-10	Steel	20'	19	23-1/4	20-3/8	22-5/8	17-1/8	7-1/8	20-1/2	35'-6"	12'-2-7/8"	4	4	
	10'	AL-FS-500-34-63-10	Alum	20'	36	23-3/8	22-5/8	-	15-1/4	7-7/8	43-7/8	35'-6"	12'-5-1/8"	4	4	
	12'	GLCS-FS-500-34 (S or AL)-63-12	Steel	20'	19	23-1/4	20-3/4	22-5/8	17-1/8	7-1/8	20-1/2	35'-6"	14'-2-7/8"	4	4	
	12'	AL-FS-500-34-63-12	Alum	20'	36	23-3/8	22-5/8	-	15-1/4	7-7/8	43-7/8	35'-6"	14'-5-1/8"	4	4	
64'	10'	GLCS-FS-500-34 (S or AL)-63-14	Steel	20'	19	23-1/4	20-3/8	22-5/8	17-1/8	7-1/8	20-1/2	35'-6"	16'-2-7/8"	4	4	
	12'	AL-FS-500-34-63-14	Alum	20'	36	23-3/8	22-5/8	-	15-1/4	7-7/8	43-7/8	35'-6"	16'-5-1/8"	4	4	
	12'	GLCSLX-FS-500-34 (S or AL)-64-10	Steel	30'	36	23-1/4	22-3/4	27	17-1/8	7-1/8	43-7/8	35'-6"	12'-5-1/4"	4	3	
	12'	GLCSLX-FS-500-34 (S or AL)-64-12	Steel	30'	36	23-1/4	22-3/4	27	17-1/8	7-1/8	43-7/8	35'-6"	14'-5-1/4"	4	3	
78'	10'	GLCSL-FS-500-34 (S or AL)-64-14	Steel	30'	36	23-1/4	22-3/4	27	17-1/8	7-1/8	43-7/8	35'-6"	16'-5-1/4"	4	3	
	10'	GLCSL-FS-500-34 (S or AL)-78-10	Steel	25'	46	23-1/4	20-3/4	25	17-1/8	7-1/8	43-7/8	35'-6"	12'-3-1/4"	4	4	
	12'	GLCSL-FS-500-34 (S or AL)-78-12	Steel	25'	46	23-1/4	20-3/4	25	17-1/8	7-1/8	43-7/8	35'-6"	14'-3-1/4"	4	4	
	14'	GLCSL-FS-500-34 (S or AL)-78-14	Steel	25'	46	23-1/4	20-3/4	25	17-1/8	7-1/8	43-7/8	35'-6"	16'-3-1/4"	4	4	
83'	10'	GLCS-FS-500-34 (S or AL)-83-10	Steel	20'	46	23-1/4	20-3/8	22-5/8	17-1/8	7-1/8	43-7/8	35'-6"	12'-2-7/8"	4	5	
	10'	AL-FS-500-34-83-10	Alum	20'	46	23-3/8	22-5/8	-	15-1/4	7-7/8	43-7/8	35'-6"	12'-5-1/8"	4	5	
	12'	GLCS-FS-500-34 (S or AL)-83-12	Steel	20'	46	23-1/4	20-3/8	22-5/8	17-1/8	7-1/8	43-7/8	35'-6"	14'-2-7/8"	4	5	
	12'	AL-FS-500-34-83-12	Alum	20'	46	23-3/8	22-5/8	-	15-1/4	7-7/8	43-7/8	35'-6"	14'-5-1/8"	4	5	
94'	10'	GLCS-FS-500-34 (S or AL)-83-14	Steel	20'	46	23-1/4	20-3/8	22-5/8	17-1/8	7-1/8	43-7/8	35'-6"	16'-2-7/8"	4	5	
	12'	AL-FS-500-34-83-14	Alum	20'	46	23-3/8	22-5/8	-	15-1/4	7-7/8	43-7/8	35'-6"	16'-5-1/8"	4	5	
	10'	GLCSLX-FS-500-34 (S or AL)-94-10	Steel	30'	54	23-1/4	22-3/4	27	17-1/8	7-1/8	43-7/8	35'-6"	12'-5-1/4"	4	4	
	12'	GLCSLX-FS-500-34 (S or AL)-94-12	Steel	30'	54	23-1/4	22-3/4	27	17-1/8	7-1/8	43-7/8	35'-6"	14'-5-1/4"	4	4	
103'	10'	GLCSLX-FS-500-34 (S or AL)-94-14	Steel	30'	54	23-1/4	22-3/4	27	17-1/8	7-1/8	43-7/8	35'-6"	16'-5-1/4"	4	4	
	10'	GLCS-FS-500-34 (S or AL)-103-10	Steel	20'	54	23-1/4	20-3/8	22-5/8	17-1/8	7-1/8	43-7/8	35'-6"	12'-2-7/8"	4	6	
	10'	AL-FS-500-34-103-10	Alum	20'	54	23-3/8	22-5/8	-	15-1/4	7-7/8	43-7/8	35'-6"	12'-5-1/8"	4	6	
	12'	GLCSL-FS-500-34 (S or AL)-103-10	Steel	25'	54	23-1/4	20-3/4	25	17-1/8	7-1/8	43-7/8	35'-6"	12'-3-1/4"	4	5	
	12'	GLCS-FS-500-34 (S or AL)-103-12	Steel	20'	54	23-1/4	20-3/8	22-5/8	17-1/8	7-1/8	43-7/8	35'-6"	14'-2-7/8"	4	6	
	12'	AL-FS-500-34-103-12	Alum	20'	54	23-3/8	22-5/8	-	15-1/4	7-7/8	43-7/8	35'-6"	14'-5-1/8"	4	6	
124'	10'	GLCSL-FS-500-34 (S or AL)-103-14	Steel	25'	54	23-1/4	20-3/4	25	17-1/8	7-1/8	43-7/8	35'-6"	14'-3-1/4"	4	5	
	12'	GLCS-FS-500-34 (S or AL)-103-14	Steel	20'	54	23-1/4	20-3/8	22-5/8	17-1/8	7-1/8	43-7/8	35'-6"	16'-2-7/8"	4	6	
	14'	AL-FS-500-34-103-14	Alum	20'	54	23-3/8	22-5/8	-	15-1/4	7-7/8	43-7/8	35'-6"	16'-5-1/8"	4	6	
	14'	GLCSL-FS-500-34 (S or AL)-103-14	Steel	25'	54	23-1/4	20-3/4	25	17-1/8	7-1/8	43-7/8	35'-6"	16'-3-1/4"	4	5	
124'	10'	GLCSLX-FS-500-34 (S or AL)-124-10	Steel	30'	54	23-1/4	22-3/4	27	17-1/4	7-1/8	43-7/8	35'-6"	12'-5-1/4"	4	5	
	12'	GLCSLX-FS-500-34 (S or AL)-124-12	Steel	30'	54	23-1/4	22-3/4	27	17-1/4	7-1/8	43-7/8	35'-6"	14'-5-1/4"	4	5	
	14'	GLCSLX-FS-500-34 (S or AL)-124-14	Steel	30'	54	23-1/4	22-3/4	27	17-1/4	7-1/8	43-7/8	35'-6"	16'-5-1/4"	4	5	

*This column provides the total number of support assemblies based on the "L1" dimensions shown. Support assemblies are designed to AISC specifications and do not require bracing. If no movement of the support assembly is preferred, then bracing to the building steel is recommended (not included).

To Determine Hook Coverage: [Bridge Travel on Runway = Runway Length - (2xL8)] by [Hoist Trolley Travel on Bridge = Bridge Length - L3 - L6] (L6 allows for festoon stack-up).

Gorbel Free Standing Work Station Bridge Crane kits include: bridge, runways, the appropriate number of support assemblies, hoist trolley, end trucks, end stops, flat wire festooning, festoon gliders (festoon trolleys on steel runway lengths greater than 63' and all aluminum systems), festoon stack-up section, splice joints and hanger brackets. Hoist and anchor bolts provided by others.

Dimensions are for reference only and are subject to change without notice.

FREE STANDING WORK STATION BRIDGE CRANES

BRIDGE LENGTH (L)	RUNWAY LENGTH	TS	MODEL NUMBER	TRACK MAT.	RUNWAY			BRIDGE						SUPPORT STRUCTURE			
					MAX. L1	L7 in	L8 in	H3 in	H3A in	H4 in	L3 in	L6 in	OAW	OAH	D in	Sp. in	
10'	11' 6"	10'	GLCS-FS-1000-10 (S or AL)-11.5-10	Steel	20'	9	15	18-1/8	22-1/8	7-5/8	7-7/8	13-3/8	11'-6"	11'-10-5/8"	4	2	
		12'	GLCS-FS-1000-10 (S or AL)-11.5-12	Steel	20'	9	15	18-1/8	22-1/8	7-5/8	7-7/8	13-3/8	11'-6"	13'-10-5/8"	4	2	
		14'	GLCS-FS-1000-10 (S or AL)-11.5-14	Steel	20'	9	15	18-1/8	22-1/8	7-5/8	7-7/8	13-3/8	11'-8"	15'-10-5/8"	5	2	
	23'	10'	GLCS-FS-1000-10 (S or AL)-23-10	Steel	20'	9	15	18-1/8	22-1/8	7-5/8	7-7/8	13-3/8	11'-6"	11'-10-5/8"	4	2	
		10'	AL-FS-1000-10-23-10	Alum	20'	13	15	22-1/8	-	13-1/8	7-7/8	17-1/2	11'-6"	12'-2-5/8"	4	2	
		12'	GLCS-FS-1000-10 (S or AL)-23-12	Steel	20'	9	15	18-1/8	22-1/8	7-5/8	7-7/8	13-3/8	11'-6"	13'-10-5/8"	4	2	
		12'	AL-FS-1000-10-23-12	Alum	20'	13	15	22-1/8	-	13-1/8	7-7/8	17-1/2	11'-6"	14'-2-5/8"	4	2	
		14'	GLCS-FS-1000-10 (S or AL)-23-14	Steel	20'	9	15	18-1/8	22-1/8	7-5/8	7-7/8	13-3/8	11'-8"	15'-10-5/8"	5	2	
		14'	AL-FS-1000-10-23-14	Alum	20'	13	15	22-1/8	-	13-1/8	7-7/8	17-1/2	11'-8"	16'-2-5/8"	5	2	
	28'	10'	GLCSL-FS-1000-10 (S or AL)-28-10	Steel	25'	13	15	21	25	7-5/8	7-7/8	13-3/8	11'-6"	12'-1-1/2"	4	2	
		12'	GLCSL-FS-1000-10 (S or AL)-28-12	Steel	25'	13	15	21	25	7-5/8	7-7/8	13-3/8	11'-6"	14'-1-1/2"	4	2	
		14'	GLCSL-FS-1000-10 (S or AL)-28-14	Steel	25'	13	15	21	25	7-5/8	7-7/8	13-3/8	11'-8"	16'-1-1/2"	5	2	
	33'	10'	GLCS-FS-1000-10 (S or AL)-33-10	Steel	20'	13	15	18-1/8	22-1/8	7-5/8	7-7/8	13-3/8	11'-6"	11'-10-5/8"	4	3	
		10'	AL-FS-1000-10-33-10	Alum	20'	19	15	22-1/8	-	13-1/8	7-7/8	17-1/2	11'-6"	12'-2-5/8"	4	3	
		12'	GLCS-FS-1000-10 (S or AL)-33-12	Steel	20'	13	15	18-1/8	22-1/8	7-5/8	7-7/8	13-3/8	11'-6"	13'-10-5/8"	4	3	
		12'	AL-FS-1000-10-33-12	Alum	20'	19	15	22-1/8	-	13-1/8	7-7/8	17-1/2	11'-6"	14'-2-5/8"	4	3	
		14'	GLCS-FS-1000-10 (S or AL)-33-14	Steel	20'	13	15	18-1/8	22-1/8	7-5/8	7-7/8	13-3/8	11'-8"	15'-10-5/8"	5	3	
		14'	AL-FS-1000-10-33-14	Alum	20'	19	15	22-1/8	-	13-1/8	7-7/8	17-1/2	11'-8"	16'-2-5/8"	5	3	
	34'	10'	GLCSLX-FS-1000-10 (S or AL)-34-10	Steel	30'	13	15	24-1/8	28-1/8	7-5/8	7-7/8	13-3/8	11'-6"	12'-4-5/8"	4	2	
		12'	GLCSLX-FS-1000-10 (S or AL)-34-12	Steel	30'	13	15	24-1/8	28-1/8	7-5/8	7-7/8	13-3/8	11'-6"	14'-4-5/8"	4	2	
		14'	GLCSLX-FS-1000-10 (S or AL)-34-14	Steel	30'	13	15	24-1/8	28-1/8	7-5/8	7-7/8	13-3/8	11'-8"	16'-4-5/8"	5	2	
	43'	10'	GLCS-FS-1000-10 (S or AL)-43-10	Steel	20'	19	15	18-1/8	22-1/8	7-5/8	7-7/8	13-3/8	11'-6"	11'-10-5/8"	4	3	
		10'	AL-FS-1000-10-43-10	Alum	20'	26	15	22-1/8	-	13-1/8	7-7/8	17-1/2	11'-6"	12'-2-5/8"	4	3	
		12'	GLCS-FS-1000-10 (S or AL)-43-12	Steel	20'	19	15	18-1/8	22-1/8	7-5/8	7-7/8	13-3/8	11'-6"	13'-10-5/8"	4	3	
		12'	AL-FS-1000-10-43-12	Alum	20'	26	15	22-1/8	-	13-1/8	7-7/8	17-1/2	11'-6"	14'-2-5/8"	4	3	
		14'	GLCS-FS-1000-10 (S or AL)-43-14	Steel	20'	19	15	18-1/8	22-1/8	7-5/8	7-7/8	13-3/8	11'-8"	15'-10-5/8"	5	3	
		14'	AL-FS-1000-10-43-14	Alum	20'	26	15	22-1/8	-	13-1/8	7-7/8	17-1/2	11'-8"	16'-2-5/8"	5	3	
	53'	10'	GLCS-FS-1000-10 (S or AL)-53-10	Steel	20'	19	15	18-1/8	22-1/8	7-5/8	7-7/8	13-3/8	11'-6"	11'-10-5/8"	4	4	
		10'	AL-FS-1000-10-53-10	Alum	20'	30	15	22-1/8	-	13-1/8	7-7/8	17-1/2	11'-6"	12'-2-5/8"	4	4	
		12'	GLCSL-FS-1000-10 (S or AL)-53-10	Steel	25'	19	15	21	25	7-5/8	7-7/8	13-3/8	11'-6"	12'-1-1/2"	4	3	
		12'	GLCS-FS-1000-10 (S or AL)-53-12	Steel	20'	19	15	18-1/8	22-1/8	7-5/8	7-7/8	13-3/8	11'-6"	13'-10-5/8"	4	4	
		12'	AL-FS-1000-10-53-12	Alum	20'	30	15	22-1/8	-	13-1/8	7-7/8	17-1/2	11'-6"	14'-2-5/8"	4	4	
		14'	GLCSL-FS-1000-10 (S or AL)-53-12	Steel	25'	19	15	21	25	7-5/8	7-7/8	13-3/8	11'-6"	14'-1-1/2"	4	3	
	63'	10'	GLCS-FS-1000-10 (S or AL)-63-10	Steel	20'	19	15	18-1/8	22-1/8	7-5/8	7-7/8	13-3/8	11'-6"	11'-10-5/8"	4	4	
		10'	AL-FS-1000-10-63-10	Alum	20'	36	15	22-1/8	-	13-1/8	7-7/8	17-1/2	11'-6"	12'-2-5/8"	4	4	
		12'	GLCS-FS-1000-10 (S or AL)-63-12	Steel	20'	26	15	18-1/8	22-1/8	7-5/8	7-7/8	13-3/8	11'-6"	13'-10-5/8"	4	4	
		12'	AL-FS-1000-10-63-12	Alum	20'	36	15	22-1/8	-	13-1/8	7-7/8	17-1/2	11'-6"	14'-2-5/8"	4	4	
		14'	GLCS-FS-1000-10 (S or AL)-63-14	Steel	20'	26	15	18-1/8	22-1/8	7-5/8	7-7/8	13-3/8	11'-8"	15'-10-5/8"	5	4	
		14'	AL-FS-1000-10-63-14	Alum	20'	36	15	22-1/8	-	13-1/8	7-7/8	17-1/2	11'-8"	16'-2-5/8"	5	4	
	64'	10'	GLCSLX-FS-1000-10 (S or AL)-64-10	Steel	30'	36	15	24-1/8	28-1/8	7-5/8	7-7/8	23-3/8	11'-6"	12'-4-5/8"	4	3	
		12'	GLCSLX-FS-1000-10 (S or AL)-64-12	Steel	30'	36	15	24-1/8	28-1/8	7-5/8	7-7/8	23-3/8	11'-6"	14'-4-5/8"	4	3	
		14'	GLCSLX-FS-1000-10 (S or AL)-64-14	Steel	30'	36	15	24-1/8	28-1/8	7-5/8	7-7/8	23-3/8	11'-8"	16'-4-5/8"	5	3	
	78'	10'	GLCSL-FS-1000-10 (S or AL)-78-10	Steel	25'	46	15	21	25	7-5/8	7-7/8	23-3/8	11'-6"	12'-1-1/2"	4	4	
		12'	GLCSL-FS-1000-10 (S or AL)-78-12	Steel	25'	46	15	21	25	7-5/8	7-7/8	23-3/8	11'-6"	14'-1-1/2"	4	4	
		14'	GLCSL-FS-1000-10 (S or AL)-78-14	Steel	25'	46	15	21	25	7-5/8	7-7/8	23-3/8	11'-8"	16'-1-1/2"	5	4	
	83'	10'	GLCS-FS-1000-10 (S or AL)-83-10	Steel	20'	46	15	18-1/8	22-1/8	7-5/8	7-7/8	23-3/8	11'-6"	11'-10-5/8"	4	5	
		10'	AL-FS-1000-10-83-10	Alum	20'	46	15	22-1/8	-	13-1/8	7-7/8	17-1/2	11'-6"	12'-2-5/8"	4	5	
		12'	GLCS-FS-1000-10 (S or AL)-83-12	Steel	20'	46	15	18-1/8	22-1/8	7-5/8	7-7/8	23-3/8	11'-6"	13'-10-5/8"	4	5	
		12'	AL-FS-1000-10-83-12	Alum	20'	46	15	22-1/8	-	13-1/8	7-7/8	17-1/2	11'-6"	14'-2-5/8"	4	5	
		14'	GLCS-FS-1000-10 (S or AL)-83-14	Steel	20'	46	15	18-1/8	22-1/8	7-5/8	7-7/8	23-3/8	11'-8"	15'-10-5/8"	5	5	
		14'	AL-FS-1000-10-83-14	Alum	20'	46	15	22-1/8	-	13-1/8	7-7/8	17-1/2	11'-8"	16'-2-5/8"	5	5	
	94'	10'	GLCSLX-FS-1000-10 (S or AL)-94-10	Steel	30'	54	15	24-1/8	28-1/8	7-5/8	7-7/8	23-3/8	11'-6"	12'-4-5/8"	4	4	
		12'	GLCSLX-FS-1000-10 (S or AL)-94-12	Steel	30'	54	15	24-1/8	28-1/8	7-5/8	7-7/8	23-3/8	11'-6"	14'-4-5/8"	4	4	
		14'	GLCSLX-FS-1000-10 (S or AL)-94-14	Steel	30'	54	15	24-1/8	28-1/8	7-5/8	7-7/8	23-3/8	11'-8"	16'-4-5/8"	5	4	
	103'	10'	GLCS-FS-1000-10 (S or AL)-103-10	Steel	20'	54	15	18-1/8	22-1/8	7-5/8	7-7/8	23-3/8	11'-6"	11'-10-5/8"	4	6	
		10'	AL-FS-1000-10-103-10	Alum	20'	54	15	22-1/8	-	13-1/8	7-7/8	17-1/2	11'-6"	12'-2-5/8"	4	6	
		12'	GLCSL-FS-1000-10 (S or AL)-103-10	Steel	25'	54	15	21	25	7-5/8	7-7/8	23-3/8	11'-6"	12'-1-1/2"	4	5	
		12'	GLCS-FS-1000-10 (S or AL)-103-12	Steel	20'	54	15	18-1/8	22-1/8	7-5/8	7-7/8	23-3/8	11'-6"	13'-10-5/8"	4	6	
		12'	AL-FS-1000-10-103-12	Alum	20'	54	15	22-1/8	-	13-1/8	7-7/8	17-1/2	11'-6"	14'-2-5/8"	4	6	
		14'	GLCSL-FS-1000-10 (S or AL)-103-12	Steel	25'	54	15	21	25	7-5/8	7-7/8	23-3/8	11'-6"	14'-1-1/2"	4	5	
	124'	10'	GLCS-FS-1000-10 (S or AL)-103-14	Steel	20'	54	15	18-1/8	22-1/8	7-5/8	7-7/8	23-3/8	11'-8"	15'-10-5/8"	5	6	
		10'	AL-FS-1000-10-103-14	Alum	20'	54	15	22-1/8	-	13-1/8	7-7/8	17-1/2	11'-8"	16'-2-5/8"	5	6	
		12'	GLCSL-FS-1000-10 (S or AL)-103-14	Steel	25'	54	15	21	25	7-5/8	7-7/8	23-3/8	11'-8"	16'-1-1/2"	5	5	
		12'	GLCSLX-FS-1000-10 (S or AL)-124-10	Steel	30'	54	15	24-1/8	28-1/8	7-5/8	7-7/8	23-3/8	11'-6"	12'-4-5/8"	4	5	
		14'	GLCSLX-FS-1000-10 (S or AL)-124-12	Steel	30'	54	15	24-1/8	28-1/8	7-5/8	7-7/8	23-3/8	11'-6"	14'-4-5/8"	4	5	
		14'	GLCSLX-FS-1000-10 (S or AL)-124-14	Steel	30'	54	15	24-1/8	28-1/8	7-5/8	7-7/8	23-3/8	11'-8"	16'-4-5/8"	5	5	

*This column provides the total number of support assemblies based on the "L1" dimensions shown. Support assemblies are designed to AISC specifications and do not require bracing. If no movement of the support assembly is preferred, then bracing to the building steel is recommended (not included).
To Determine Hook Coverage: [Bridge Travel on Runway = Runway Length - (2xL8)] by [Hoist Trolley Travel on Bridge = Bridge Length - L3 - L6] (L6 allows for festoon stack-up).
Gorbel Free Standing Work Station Bridge Crane kits include: bridge, runways, the appropriate number of support assemblies, hoist trolley, end trucks, end stops, flat wire festooning, festoon gliders (festoon trolleys on steel runway lengths greater than 63' and all aluminum systems), festoon stack-up section, splice joints and hanger brackets. Hoist and anchor bolts provided by others.
Dimensions are for reference only and are subject to change without notice.

FREE STANDING WORK STATION BRIDGE CRANES

BRIDGE LENGTH (L)	RUNWAY LENGTH	TS	MODEL NUMBER	TRACK MAT.	RUNWAY			BRIDGE				SUPPORT STRUCTURE				
					MAX. L1	L7 in	L8 in	H3 in	H3A in	H4 in	L3 in	L6 in	OAW	OAH	D in	J-kg
15'	23'	10'	GLCS-FS-1000-15 (S or AL)-23-10	Steel	20'	9	15	18-1/8	22-1/8	14-1/8	7-7/8	23-3/8	16'-6"	11'-10-5/8"	4	2
		10'	AL-FS-1000-15-23-10	Alum	20'	13	15	22-1/8	-	13-1/8	7-7/8	24-1/4	16'-6"	12'-2-5/8"	4	2
		12'	GLCS-FS-1000-15 (S or AL)-23-12	Steel	20'	9	15	18-1/8	22-1/8	14-1/8	7-7/8	23-3/8	16'-6"	13'-10-5/8"	4	2
		12'	AL-FS-1000-15-23-12	Alum	20'	13	15	22-1/8	-	13-1/8	7-7/8	24-1/4	16'-6"	14'-2-5/8"	4	2
	14'	GLCS-FS-1000-15 (S or AL)-23-14	Steel	20'	9	15	18-1/8	22-1/8	14-1/8	7-7/8	23-3/8	16'-8"	15'-10-5/8"	5	2	
	14'	AL-FS-1000-15-23-14	Alum	20'	13	15	22-1/8	-	13-1/8	7-7/8	24-1/4	16'-8"	16'-2-5/8"	5	2	
	28'	10'	GLCSL-FS-1000-15 (S or AL)-28-10	Steel	25'	13	15	21	25	14-1/8	7-7/8	23-3/8	16'-6"	12'-1-1/2"	4	2
		12'	GLCSL-FS-1000-15 (S or AL)-28-12	Steel	25'	13	15	21	25	14-1/8	7-7/8	23-3/8	16'-6"	14'-1-1/2"	4	2
		14'	GLCSL-FS-1000-15 (S or AL)-28-14	Steel	25'	13	15	21	25	14-1/8	7-7/8	23-3/8	16'-8"	16'-1-1/2"	5	2
	33'	10'	GLCS-FS-1000-15 (S or AL)-33-10	Steel	20'	13	15	18-1/8	22-1/8	14-1/8	7-7/8	23-3/8	16'-6"	11'-10-5/8"	4	3
		10'	AL-FS-1000-15-33-10	Alum	20'	19	15	22-1/8	-	13-1/8	7-7/8	24-1/4	16'-6"	12'-2-5/8"	4	3
		12'	GLCS-FS-1000-15 (S or AL)-33-12	Steel	20'	13	15	18-1/8	22-1/8	14-1/8	7-7/8	23-3/8	16'-6"	13'-10-5/8"	4	3
12'		AL-FS-1000-15-33-12	Alum	20'	19	15	22-1/8	-	13-1/8	7-7/8	24-1/4	16'-6"	14'-2-5/8"	4	3	
34'	10'	GLCSLX-FS-1000-15 (S or AL)-34-10	Steel	30'	13	15	24-1/8	28-1/8	14-1/8	7-7/8	23-3/8	16'-6"	11'-10-5/8"	4	2	
	12'	GLCSLX-FS-1000-15 (S or AL)-34-12	Steel	30'	13	15	24-1/8	28-1/8	14-1/8	7-7/8	23-3/8	16'-6"	14'-4-5/8"	4	2	
	14'	GLCSLX-FS-1000-15 (S or AL)-34-14	Steel	30'	13	15	24-1/8	28-1/8	14-1/8	7-7/8	23-3/8	16'-8"	16'-4-5/8"	5	2	
	10'	GLCS-FS-1000-15 (S or AL)-43-10	Steel	20'	19	15	18-1/8	22-1/8	14-1/8	7-7/8	23-3/8	16'-6"	11'-10-5/8"	4	3	
43'	10'	AL-FS-1000-15-43-10	Alum	20'	26	15	22-1/8	-	13-1/8	7-7/8	24-1/4	16'-6"	12'-2-5/8"	4	3	
	12'	GLCS-FS-1000-15 (S or AL)-43-12	Steel	20'	19	15	18-1/8	22-1/8	14-1/8	7-7/8	23-3/8	16'-6"	13'-10-5/8"	4	3	
	12'	AL-FS-1000-15-43-12	Alum	20'	26	15	22-1/8	-	13-1/8	7-7/8	24-1/4	16'-6"	14'-2-5/8"	4	3	
	14'	GLCS-FS-1000-15 (S or AL)-43-14	Steel	20'	19	15	18-1/8	22-1/8	14-1/8	7-7/8	23-3/8	16'-8"	15'-10-5/8"	5	3	
53'	14'	AL-FS-1000-15-43-14	Alum	20'	26	15	22-1/8	-	13-1/8	7-7/8	24-1/4	16'-8"	16'-2-5/8"	5	3	
	10'	GLCS-FS-1000-15 (S or AL)-53-10	Steel	20'	19	15	18-1/8	22-1/8	14-1/8	7-7/8	23-3/8	16'-6"	11'-10-5/8"	4	4	
	10'	AL-FS-1000-15-53-10	Alum	20'	30	15	22-1/8	-	13-1/8	7-7/8	24-1/4	16'-6"	12'-2-5/8"	4	4	
	10'	GLCSL-FS-1000-15 (S or AL)-53-10	Steel	25'	19	15	21	25	14-1/8	7-7/8	23-3/8	16'-6"	12'-1-1/2"	4	3	
63'	12'	GLCS-FS-1000-15 (S or AL)-53-12	Steel	20'	19	15	18-1/8	22-1/8	14-1/8	7-7/8	23-3/8	16'-6"	13'-10-5/8"	4	4	
	12'	AL-FS-1000-15-53-12	Alum	20'	30	15	22-1/8	-	13-1/8	7-7/8	24-1/4	16'-6"	14'-2-5/8"	4	4	
	12'	GLCSL-FS-1000-15 (S or AL)-53-12	Steel	25'	19	15	21	25	14-1/8	7-7/8	23-3/8	16'-6"	14'-1-1/2"	4	3	
	14'	GLCS-FS-1000-15 (S or AL)-53-14	Steel	20'	19	15	18-1/8	22-1/8	14-1/8	7-7/8	23-3/8	16'-8"	15'-10-5/8"	5	4	
64'	14'	AL-FS-1000-15-53-14	Alum	20'	30	15	22-1/8	-	13-1/8	7-7/8	24-1/4	16'-8"	16'-2-5/8"	5	4	
	14'	GLCSL-FS-1000-15 (S or AL)-53-14	Steel	25'	19	15	21	25	14-1/8	7-7/8	23-3/8	16'-8"	16'-1-1/2"	5	3	
	10'	GLCS-FS-1000-15 (S or AL)-63-10	Steel	20'	26	15	18-1/8	22-1/8	14-1/8	7-7/8	23-3/8	16'-6"	11'-10-5/8"	4	4	
	10'	AL-FS-1000-15-63-10	Alum	20'	36	15	22-1/8	-	13-1/8	7-7/8	24-1/4	16'-6"	12'-2-5/8"	4	4	
78'	12'	GLCS-FS-1000-15 (S or AL)-63-12	Steel	20'	26	15	18-1/8	22-1/8	14-1/8	7-7/8	23-3/8	16'-6"	13'-10-5/8"	4	4	
	12'	AL-FS-1000-15-63-12	Alum	20'	36	15	22-1/8	-	13-1/8	7-7/8	24-1/4	16'-6"	14'-2-5/8"	4	4	
	14'	GLCS-FS-1000-15 (S or AL)-63-14	Steel	20'	26	15	18-1/8	22-1/8	14-1/8	7-7/8	23-3/8	16'-8"	15'-10-5/8"	5	4	
	14'	AL-FS-1000-15-63-14	Alum	20'	36	15	22-1/8	-	13-1/8	7-7/8	24-1/4	16'-8"	16'-2-5/8"	5	4	
83'	10'	GLCSLX-FS-1000-15 (S or AL)-64-10	Steel	30'	36	15	24-1/8	28-1/8	14-1/8	7-7/8	24-1/4	16'-6"	11'-10-5/8"	4	3	
	12'	GLCSLX-FS-1000-15 (S or AL)-64-12	Steel	30'	36	15	24-1/8	28-1/8	14-1/8	7-7/8	24-1/4	16'-6"	14'-4-5/8"	4	3	
	14'	GLCSLX-FS-1000-15 (S or AL)-64-14	Steel	30'	36	15	24-1/8	28-1/8	14-1/8	7-7/8	24-1/4	16'-8"	16'-4-5/8"	5	3	
94'	10'	GLCSL-FS-1000-15 (S or AL)-78-10	Steel	25'	46	15	21	25	14-1/8	7-7/8	24-1/4	16'-6"	12'-1-1/2"	4	4	
	12'	GLCSL-FS-1000-15 (S or AL)-78-12	Steel	25'	46	15	21	25	14-1/8	7-7/8	24-1/4	16'-6"	14'-1-1/2"	4	4	
	14'	GLCSL-FS-1000-15 (S or AL)-78-14	Steel	25'	46	15	21	25	14-1/8	7-7/8	24-1/4	16'-8"	16'-1-1/2"	5	4	
	10'	GLCS-FS-1000-15 (S or AL)-83-10	Steel	20'	46	15	18-1/8	22-1/8	14-1/8	7-7/8	24-1/4	16'-6"	11'-10-5/8"	4	5	
103'	10'	AL-FS-1000-15-83-10	Alum	20'	46	15	22-1/8	-	13-1/8	7-7/8	24-1/4	16'-6"	12'-2-5/8"	4	5	
	12'	GLCS-FS-1000-15 (S or AL)-83-12	Steel	20'	46	15	18-1/8	22-1/8	14-1/8	7-7/8	24-1/4	16'-6"	13'-10-5/8"	4	5	
	12'	AL-FS-1000-15-83-12	Alum	20'	46	15	22-1/8	-	13-1/8	7-7/8	24-1/4	16'-6"	14'-2-5/8"	4	5	
	14'	GLCS-FS-1000-15 (S or AL)-83-14	Steel	20'	46	15	18-1/8	22-1/8	14-1/8	7-7/8	24-1/4	16'-8"	15'-10-5/8"	5	5	
103'	14'	AL-FS-1000-15-83-14	Alum	20'	46	15	22-1/8	-	13-1/8	7-7/8	24-1/4	16'-8"	16'-2-5/8"	5	5	
	10'	GLCSLX-FS-1000-15 (S or AL)-94-10	Steel	30'	54	15	24-1/8	28-1/8	14-1/8	7-7/8	24-1/4	16'-6"	12'-4-5/8"	4	4	
	12'	GLCSLX-FS-1000-15 (S or AL)-94-12	Steel	30'	54	15	24-1/8	28-1/8	14-1/8	7-7/8	24-1/4	16'-6"	14'-4-5/8"	4	4	
	14'	GLCSLX-FS-1000-15 (S or AL)-94-14	Steel	30'	54	15	24-1/8	28-1/8	14-1/8	7-7/8	24-1/4	16'-8"	16'-4-5/8"	5	4	
124'	10'	GLCS-FS-1000-15 (S or AL)-103-10	Steel	20'	54	15	18-1/8	22-1/8	14-1/8	7-7/8	24-1/4	16'-6"	11'-10-5/8"	4	6	
	10'	AL-FS-1000-15-103-10	Alum	20'	54	15	22-1/8	-	13-1/8	7-7/8	24-1/4	16'-6"	12'-2-5/8"	4	6	
	12'	GLCSL-FS-1000-15 (S or AL)-103-12	Steel	25'	54	15	21	25	14-1/8	7-7/8	24-1/4	16'-6"	12'-1-1/2"	4	5	
	12'	GLCS-FS-1000-15 (S or AL)-103-12	Steel	20'	54	15	18-1/8	22-1/8	14-1/8	7-7/8	24-1/4	16'-6"	13'-10-5/8"	4	6	
	12'	AL-FS-1000-15-103-12	Alum	20'	54	15	22-1/8	-	13-1/8	7-7/8	24-1/4	16'-6"	14'-2-5/8"	4	6	
	14'	GLCSL-FS-1000-15 (S or AL)-103-14	Steel	25'	54	15	21	25	14-1/8	7-7/8	24-1/4	16'-6"	14'-1-1/2"	4	5	
124'	14'	GLCS-FS-1000-15 (S or AL)-103-14	Steel	20'	54	15	18-1/8	22-1/8	14-1/8	7-7/8	24-1/4	16'-8"	15'-10-5/8"	5	6	
	14'	AL-FS-1000-15-103-14	Alum	20'	54	15	22-1/8	-	13-1/8	7-7/8	24-1/4	16'-8"	16'-2-5/8"	5	6	
	14'	GLCSL-FS-1000-15 (S or AL)-103-14	Steel	25'	54	15	21	25	14-1/8	7-7/8	24-1/4	16'-8"	16'-1-1/2"	5	5	
124'	10'	GLCSLX-FS-1000-15 (S or AL)-124-10	Steel	30'	54	15	24-1/8	28-1/8	14-1/8	7-7/8	24-1/4	16'-6"	12'-4-5/8"	4	5	
	12'	GLCSLX-FS-1000-15 (S or AL)-124-12	Steel	30'	54	15	24-1/8	28-1/8	14-1/8	7-7/8	24-1/4	16'-6"	14'-4-5/8"	4	5	
	14'	GLCSLX-FS-1000-15 (S or AL)-124-14	Steel	30'	54	15	24-1/8	28-1/8	14-1/8	7-7/8	24-1/4	16'-8"	16'-4-5/8"	5	5	

*This column provides the total number of support assemblies based on the "L1" dimensions shown. Support assemblies are designed to AISC specifications and do not require bracing. If no movement of the support assembly is preferred, then bracing to the building steel is recommended (not included).

To Determine Hook Coverage: [Bridge Travel on Runway - Runway Length - (2xL8)] by [Hoist Trolley Travel on Bridge = Bridge Length - L3 - L6] (L6 allows for festoon stack-up).

Gorbel Free Standing Work Station Bridge Crane kits include: bridge, runways, the appropriate number of support assemblies, hoist trolley, end trucks, and stops. Flat wire festooning, festoon gliders (festoon on steel runway lengths greater than 63' and all aluminum systems), festoon stack-up section, splice joints and hanger brackets. Hoist and anchor bolts provided by others. Dimensions are for reference only and are subject to change without notice.

FREE STANDING WORK STATION BRIDGE CRANES

BRIDGE LENGTH (L)	RUNWAY LENGTH	TS	MODEL NUMBER	TRACK MAT.	RUNWAY			BRIDGE						SUPPORT STRUCTURE			
					MAX. L1	L7 in	L8 in	H3 in	H3A in	H4 in	L3 in	L6 in	OAW	OAH	D in	g	
20'	23'	10'	GLCS-FS-1000-20 (S or AL)-23-10	Steel	20'	9	15	18-1/8	22-1/8	14-1/8	7-7/8	23-3/8	21'-6"	11'-10-5/8"	4	2	
		10'	AL-FS-1000-20-23-10	Alum	20'	13	15	22-1/8	-	13-1/8	7-7/8	27-5/8	21'-6"	12'-2-5/8"	4	2	
		12'	GLCS-FS-1000-20 (S or AL)-23-12	Steel	20'	9	15	18-1/8	22-1/8	14-1/8	7-7/8	23-3/8	21'-6"	13'-10-5/8"	4	2	
		12'	AL-FS-1000-20-23-12	Alum	20'	13	15	22-1/8	-	13-1/8	7-7/8	27-5/8	21'-6"	14'-2-5/8"	4	2	
	28'	10'	GLCSL-FS-1000-20 (S or AL)-28-10	Steel	25'	13	15	21	25	14-1/8	7-7/8	23-3/8	21'-6"	12'-1-1/2"	4	2	
		12'	GLCSL-FS-1000-20 (S or AL)-28-12	Steel	25'	13	15	21	25	14-1/8	7-7/8	23-3/8	21'-6"	14'-1-1/2"	4	2	
		14'	GLCSL-FS-1000-20 (S or AL)-28-14	Steel	25'	13	15	21	25	14-1/8	7-7/8	23-3/8	21'-8"	16'-1-1/2"	5	2	
		14'	AL-FS-1000-20-28-14	Alum	20'	13	15	22-1/8	-	13-1/8	7-7/8	27-5/8	21'-8"	16'-2-5/8"	5	2	
	33'	10'	GLCS-FS-1000-20 (S or AL)-33-10	Steel	20'	13	15	18-1/8	22-1/8	14-1/8	7-7/8	23-3/8	21'-6"	11'-10-5/8"	4	3	
		10'	AL-FS-1000-20-33-10	Alum	20'	19	15	22-1/8	-	13-1/8	7-7/8	27-5/8	21'-6"	12'-2-5/8"	4	3	
		12'	GLCS-FS-1000-20 (S or AL)-33-12	Steel	20'	13	15	18-1/8	22-1/8	14-1/8	7-7/8	23-3/8	21'-6"	13'-10-5/8"	4	3	
		12'	AL-FS-1000-20-33-12	Alum	20'	19	15	22-1/8	-	13-1/8	7-7/8	27-5/8	21'-6"	14'-2-5/8"	4	3	
	34'	10'	GLCSLX-FS-1000-20 (S or AL)-34-10	Steel	30'	13	15	24-1/8	28-1/8	14-1/8	7-7/8	23-3/8	21'-6"	12'-4-5/8"	4	2	
		12'	GLCSLX-FS-1000-20 (S or AL)-34-12	Steel	30'	13	15	24-1/8	28-1/8	14-1/8	7-7/8	23-3/8	21'-6"	14'-4-5/8"	4	2	
		14'	GLCSLX-FS-1000-20 (S or AL)-34-14	Steel	30'	13	15	24-1/8	28-1/8	14-1/8	7-7/8	23-3/8	21'-8"	16'-5-5/8"	5	2	
		14'	AL-FS-1000-20-34-14	Alum	20'	19	15	22-1/8	-	13-1/8	7-7/8	27-5/8	21'-8"	16'-2-5/8"	5	3	
	43'	10'	GLCS-FS-1000-20 (S or AL)-43-10	Steel	20'	19	15	18-1/8	22-1/8	14-1/8	7-7/8	23-3/8	21'-6"	11'-10-5/8"	4	3	
		10'	AL-FS-1000-20-43-10	Alum	20'	26	15	22-1/8	-	13-1/8	7-7/8	27-5/8	21'-6"	12'-2-5/8"	4	3	
		12'	GLCS-FS-1000-20 (S or AL)-43-12	Steel	20'	19	15	18-1/8	22-1/8	14-1/8	7-7/8	23-3/8	21'-6"	13'-10-5/8"	4	3	
		12'	AL-FS-1000-20-43-12	Alum	20'	26	15	22-1/8	-	13-1/8	7-7/8	27-5/8	21'-6"	14'-2-5/8"	4	3	
	53'	10'	GLCS-FS-1000-20 (S or AL)-53-10	Steel	20'	19	15	18-1/8	22-1/8	14-1/8	7-7/8	23-3/8	21'-6"	11'-10-5/8"	4	4	
		10'	AL-FS-1000-20-53-10	Alum	20'	30	15	22-1/8	-	13-1/8	7-7/8	27-5/8	21'-6"	12'-2-5/8"	4	4	
		12'	GLCSL-FS-1000-20 (S or AL)-53-12	Steel	25'	19	15	21	25	14-1/8	7-7/8	23-3/8	21'-6"	12'-1-1/2"	4	4	
		12'	AL-FS-1000-20-53-12	Alum	20'	19	15	18-1/8	22-1/8	14-1/8	7-7/8	23-3/8	21'-6"	13'-10-5/8"	4	4	
	63'	10'	GLCSL-FS-1000-20 (S or AL)-53-12	Steel	25'	19	15	21	25	14-1/8	7-7/8	23-3/8	21'-6"	14'-1-1/2"	4	4	
		12'	GLCS-FS-1000-20 (S or AL)-53-14	Steel	20'	19	15	18-1/8	22-1/8	14-1/8	7-7/8	23-3/8	21'-8"	15'-10-5/8"	5	4	
		14'	AL-FS-1000-20-53-14	Alum	20'	30	15	22-1/8	-	13-1/8	7-7/8	27-5/8	21'-8"	16'-2-5/8"	5	4	
		14'	GLCSL-FS-1000-20 (S or AL)-53-14	Steel	25'	19	15	21	25	14-1/8	7-7/8	23-3/8	21'-8"	16'-1-1/2"	5	3	
	64'	10'	GLCS-FS-1000-20 (S or AL)-63-10	Steel	20'	26	15	18-1/8	22-1/8	14-1/8	7-7/8	23-3/8	21'-6"	11'-10-5/8"	4	4	
		10'	AL-FS-1000-20-63-10	Alum	20'	36	15	22-1/8	-	13-1/8	7-7/8	27-5/8	21'-6"	12'-2-5/8"	4	4	
		12'	GLCS-FS-1000-20 (S or AL)-63-12	Steel	20'	26	15	18-1/8	22-1/8	14-1/8	7-7/8	23-3/8	21'-6"	13'-10-5/8"	4	4	
		12'	AL-FS-1000-20-63-12	Alum	20'	36	15	22-1/8	-	13-1/8	7-7/8	27-5/8	21'-6"	14'-2-5/8"	4	4	
	78'	10'	GLCSLX-FS-1000-20 (S or AL)-64-10	Steel	30'	36	15	24-1/8	28-1/8	14-1/8	7-7/8	27-5/8	21'-6"	12'-4-5/8"	4	3	
		12'	GLCSLX-FS-1000-20 (S or AL)-64-12	Steel	30'	36	15	24-1/8	28-1/8	14-1/8	7-7/8	27-5/8	21'-6"	14'-4-5/8"	4	3	
		14'	GLCSLX-FS-1000-20 (S or AL)-64-14	Steel	30'	36	15	24-1/8	28-1/8	14-1/8	7-7/8	27-5/8	21'-8"	16'-5-5/8"	5	3	
		14'	AL-FS-1000-20-64-14	Alum	20'	36	15	22-1/8	-	13-1/8	7-7/8	27-5/8	21'-8"	16'-2-5/8"	5	4	
	83'	10'	GLCSL-FS-1000-20 (S or AL)-78-10	Steel	25'	46	15	21	25	14-1/8	7-7/8	27-5/8	21'-6"	12'-1-1/2"	4	4	
		12'	GLCSL-FS-1000-20 (S or AL)-78-12	Steel	25'	46	15	21	25	14-1/8	7-7/8	27-5/8	21'-6"	14'-1-1/2"	4	4	
		14'	GLCSL-FS-1000-20 (S or AL)-78-14	Steel	25'	46	15	21	25	14-1/8	7-7/8	27-5/8	21'-8"	16'-1-1/2"	5	4	
		14'	AL-FS-1000-20-83-10	Alum	20'	46	15	22-1/8	-	13-1/8	7-7/8	27-5/8	21'-6"	12'-2-5/8"	4	5	
	94'	10'	GLCS-FS-1000-20 (S or AL)-83-10	Steel	20'	46	15	18-1/8	22-1/8	14-1/8	7-7/8	27-5/8	21'-6"	11'-10-5/8"	4	5	
		12'	GLCS-FS-1000-20 (S or AL)-83-12	Steel	20'	46	15	18-1/8	22-1/8	14-1/8	7-7/8	27-5/8	21'-6"	13'-10-5/8"	4	5	
		14'	GLCS-FS-1000-20 (S or AL)-83-14	Steel	20'	46	15	18-1/8	22-1/8	14-1/8	7-7/8	27-5/8	21'-8"	15'-10-5/8"	5	5	
		14'	AL-FS-1000-20-83-14	Alum	20'	46	15	22-1/8	-	13-1/8	7-7/8	27-5/8	21'-8"	16'-2-5/8"	5	5	
	103'	10'	GLCSLX-FS-1000-20 (S or AL)-94-10	Steel	30'	54	15	24-1/8	28-1/8	14-1/8	7-7/8	27-5/8	21'-6"	12'-4-5/8"	4	4	
		12'	GLCSLX-FS-1000-20 (S or AL)-94-12	Steel	30'	54	15	24-1/8	28-1/8	14-1/8	7-7/8	27-5/8	21'-6"	14'-4-5/8"	4	4	
		14'	GLCSLX-FS-1000-20 (S or AL)-94-14	Steel	30'	54	15	24-1/8	28-1/8	14-1/8	7-7/8	27-5/8	21'-8"	16'-5-5/8"	5	4	
		14'	AL-FS-1000-20-103-10	Alum	20'	54	15	22-1/8	-	13-1/8	7-7/8	27-5/8	21'-6"	11'-10-5/8"	4	6	
	124'	10'	GLCSL-FS-1000-20 (S or AL)-103-10	Steel	25'	54	15	21	25	14-1/8	7-7/8	27-5/8	21'-6"	12'-2-5/8"	4	6	
		12'	GLCS-FS-1000-20 (S or AL)-103-12	Steel	20'	54	15	18-1/8	22-1/8	14-1/8	7-7/8	27-5/8	21'-6"	12'-1-1/2"	4	5	
		14'	GLCSL-FS-1000-20 (S or AL)-103-12	Steel	25'	54	15	21	25	14-1/8	7-7/8	27-5/8	21'-6"	14'-1-1/2"	4	5	
		14'	GLCS-FS-1000-20 (S or AL)-103-14	Steel	20'	54	15	18-1/8	22-1/8	14-1/8	7-7/8	27-5/8	21'-8"	15'-10-5/8"	5	6	
	124'	10'	AL-FS-1000-20-103-14	Alum	20'	54	15	22-1/8	-	13-1/8	7-7/8	27-5/8	21'-8"	16'-2-5/8"	5	6	
		12'	GLCSL-FS-1000-20 (S or AL)-124-10	Steel	30'	54	15	24-1/8	28-1/8	14-1/8	7-7/8	27-5/8	21'-6"	12'-4-5/8"	4	5	
		14'	GLCSLX-FS-1000-20 (S or AL)-124-12	Steel	30'	54	15	24-1/8	28-1/8	14-1/8	7-7/8	27-5/8	21'-6"	14'-4-5/8"	4	5	
		14'	GLCSLX-FS-1000-20 (S or AL)-124-14	Steel	30'	54	15	24-1/8	28-1/8	14-1/8	7-7/8	27-5/8	21'-8"	16'-5-5/8"	5	5	

*This column provides the total number of support assemblies based on the "L1" dimensions shown. Support assemblies are designed to AISC specifications and do not require bracing. If no movement of the support assembly is preferred, then bracing to the building steel is recommended (not included).
 To Determine Hook Coverage: [Bridge Travel on Runway = Runway Length - (2xL8)] by [Hoist Trolley Travel on Bridge = Bridge Length - L3 - L6] (L6 allows for festoon stack-up).
 Gorbels Free Standing Work Station Bridge Crane kits include: bridge, runways, the appropriate number of support assemblies, hoist trolley, end trucks, end stops, flat wire festooning, festoon gliders (festoon trolleys on steel runway lengths greater than 63' and all aluminum systems), festoon stack-up section, splice joints and hanger brackets. Hoist and anchor bolts provided by others.
 Dimensions are for reference only and are subject to change without notice.

FREE STANDING WORK STATION BRIDGE CRANES

BRIDGE LENGTH (L)	RUNWAY LENGTH	TS	MODEL NUMBER	TRACK MAT.	RUNWAY			BRIDGE						SUPPORT STRUCTURE		
					MAX. L1	L7 in	L8 in	H3 in	H3A in	H4 in	L3 in	L6 in	OAW	OAH	D in	Lds
23'	10'	10'	GLCS-FS--1000-23 (S or AL)-23-10	Steel	20'	9	15	18-1/8	22-1/8	14-1/8	7-7/8	23-3/8	24'-6"	11'-11-5/8"	4	2
		10'	AL-FS-1000-23-23-10	Alum	20'	9	15	22-1/8	-	13-1/8	7-7/8	31	24'-6"	12'-3-5/8"	4	2
		12'	GLCS-FS--1000-23 (S or AL)-23-12	Steel	20'	9	15	18-1/8	22-1/8	14-1/8	7-7/8	23-3/8	24'-6"	13'-11-5/8"	4	2
		12'	AL-FS-1000-23-23-12	Alum	20'	9	15	22-1/8	-	13-1/8	7-7/8	31	24'-6"	14'-3-5/8"	4	2
		14'	GLCS-FS--1000-23 (S or AL)-23-14	Steel	20'	9	15	18-1/8	22-1/8	14-1/8	7-7/8	23-3/8	24'-8"	15'-11-5/8"	5	2
		14'	AL-FS-1000-23-23-14	Alum	20'	9	15	22-1/8	-	13-1/8	7-7/8	31	24'-8"	16'-3-5/8"	5	2
	28'	10'	GLCSL-FS--1000-23 (S or AL)-28-10	Steel	25'	13	15	21	25	14-1/8	7-7/8	23-3/8	24'-6"	12'-2-1/2"	4	2
		12'	GLCSL-FS--1000-23 (S or AL)-28-12	Steel	25'	13	15	21	25	14-1/8	7-7/8	23-3/8	24'-6"	14'-2-1/2"	4	2
		14'	GLCSL-FS--1000-23 (S or AL)-28-14	Steel	25'	13	15	21	25	14-1/8	7-7/8	23-3/8	24'-8"	16'-2-1/2"	5	2
	33'	10'	GLCS-FS--1000-23 (S or AL)-33-10	Steel	20'	13	15	18-1/8	22-1/8	14-1/8	7-7/8	23-3/8	24'-6"	11'-11-5/8"	4	3
		10'	AL-FS-1000-23-33-10	Alum	20'	13	15	22-1/8	-	13-1/8	7-7/8	31	24'-6"	12'-3-5/8"	4	3
		12'	GLCS-FS--1000-23 (S or AL)-33-12	Steel	20'	13	15	18-1/8	22-1/8	14-1/8	7-7/8	23-3/8	24'-6"	13'-11-5/8"	4	3
12'		AL-FS-1000-23-33-12	Alum	20'	13	15	22-1/8	-	13-1/8	7-7/8	31	24'-6"	14'-3-5/8"	4	3	
34'	10'	GLCSLX-FS--1000-23 (S or AL)-34-10	Steel	30'	13	15	24-1/8	28-1/8	14-1/8	7-7/8	23-3/8	24'-6"	12'-5-5/8"	4	2	
	12'	GLCSLX-FS--1000-23 (S or AL)-34-12	Steel	30'	13	15	24-1/8	28-1/8	14-1/8	7-7/8	23-3/8	24'-6"	14'-5-5/8"	4	2	
	14'	GLCSLX-FS--1000-23 (S or AL)-34-14	Steel	30'	13	15	24-1/8	28-1/8	14-1/8	7-7/8	23-3/8	24'-8"	16'-5-5/8"	5	2	
	10'	GLCS-FS--1000-23 (S or AL)-43-10	Steel	20'	19	15	18-1/8	22-1/8	14-1/8	7-7/8	23-3/8	24'-6"	11'-11-5/8"	4	3	
43'	10'	AL-FS-1000-23-43-10	Alum	20'	26	15	22-1/8	-	13-1/8	7-7/8	31	24'-6"	12'-3-5/8"	4	3	
	12'	GLCS-FS--1000-23 (S or AL)-43-12	Steel	20'	19	15	18-1/8	22-1/8	14-1/8	7-7/8	23-3/8	24'-6"	13'-11-5/8"	4	3	
	12'	AL-FS-1000-23-43-12	Alum	20'	26	15	22-1/8	-	13-1/8	7-7/8	31	24'-6"	14'-3-5/8"	4	3	
	14'	GLCS-FS--1000-23 (S or AL)-43-14	Steel	20'	19	15	18-1/8	22-1/8	14-1/8	7-7/8	23-3/8	24'-8"	15'-11-5/8"	5	3	
53'	10'	AL-FS-1000-23-43-14	Alum	20'	26	15	22-1/8	-	13-1/8	7-7/8	31	24'-8"	16'-3-5/8"	5	3	
	10'	GLCS-FS--1000-23 (S or AL)-53-10	Steel	20'	19	15	18-1/8	22-1/8	14-1/8	7-7/8	23-3/8	24'-6"	11'-11-5/8"	4	4	
	10'	AL-FS-1000-23-53-10	Alum	20'	30	15	22-1/8	-	13-1/8	7-7/8	31	24'-6"	12'-3-5/8"	4	4	
	12'	GLCSL-FS--1000-23 (S or AL)-53-10	Steel	25'	19	15	21	25	14-1/8	7-7/8	23-3/8	24'-6"	12'-2-1/2"	4	3	
	12'	GLCS-FS--1000-23 (S or AL)-53-12	Steel	20'	19	15	18-1/8	22-1/8	14-1/8	7-7/8	23-3/8	24'-6"	13'-11-5/8"	4	4	
	12'	AL-FS-1000-23-53-12	Alum	20'	30	15	22-1/8	-	13-1/8	7-7/8	31	24'-6"	14'-3-5/8"	4	4	
	12'	GLCSL-FS--1000-23 (S or AL)-53-12	Steel	25'	19	15	21	25	14-1/8	7-7/8	23-3/8	24'-6"	14'-2-1/2"	4	3	
	14'	GLCS-FS--1000-23 (S or AL)-53-14	Steel	20'	19	15	18-1/8	22-1/8	14-1/8	7-7/8	23-3/8	24'-8"	15'-11-5/8"	5	4	
	14'	AL-FS-1000-23-53-14	Alum	20'	30	15	22-1/8	-	13-1/8	7-7/8	31	24'-8"	16'-3-5/8"	5	4	
	14'	GLCSL-FS--1000-23 (S or AL)-53-14	Steel	25'	19	15	21	25	14-1/8	7-7/8	23-3/8	24'-8"	16'-2-1/2"	5	3	
	63'	10'	GLCS-FS--1000-23 (S or AL)-63-10	Steel	20'	26	15	18-1/8	22-1/8	14-1/8	7-7/8	23-3/8	24'-6"	11'-11-5/8"	4	4
		10'	AL-FS-1000-23-63-10	Alum	20'	36	15	22-1/8	-	13-1/8	7-7/8	31	24'-6"	12'-3-5/8"	4	4
12'		GLCS-FS--1000-23 (S or AL)-63-12	Steel	20'	26	15	18-1/8	22-1/8	14-1/8	7-7/8	23-3/8	24'-6"	13'-11-5/8"	4	4	
12'		AL-FS-1000-23-63-12	Alum	20'	36	15	22-1/8	-	13-1/8	7-7/8	31	24'-6"	14'-3-5/8"	4	4	
14'		GLCS-FS--1000-23 (S or AL)-63-14	Steel	20'	26	15	18-1/8	22-1/8	14-1/8	7-7/8	23-3/8	24'-8"	15'-11-5/8"	5	4	
14'		AL-FS-1000-23-63-14	Alum	20'	36	15	22-1/8	-	13-1/8	7-7/8	31	24'-8"	16'-3-5/8"	5	4	
64'	10'	GLCSLX-FS--1000-23 (S or AL)-64-10	Steel	30'	36	15	24-1/8	28-1/8	14-1/8	7-7/8	31	24'-6"	12'-5-5/8"	4	3	
	12'	GLCSLX-FS--1000-23 (S or AL)-64-12	Steel	30'	36	15	24-1/8	28-1/8	14-1/8	7-7/8	31	24'-6"	14'-5-5/8"	4	3	
	14'	GLCSLX-FS--1000-23 (S or AL)-64-14	Steel	30'	36	15	24-1/8	28-1/8	14-1/8	7-7/8	31	24'-8"	16'-5-5/8"	5	3	
78'	10'	GLCSL-FS--1000-23 (S or AL)-78-10	Steel	25'	46	15	21	25	14-1/8	7-7/8	31	24'-6"	12'-2-1/2"	4	4	
	12'	GLCSL-FS--1000-23 (S or AL)-78-12	Steel	25'	46	15	21	25	14-1/8	7-7/8	31	24'-6"	14'-2-1/2"	4	4	
	14'	GLCSL-FS--1000-23 (S or AL)-78-14	Steel	25'	46	15	21	25	14-1/8	7-7/8	31	24'-8"	16'-2-1/2"	5	4	
83'	10'	GLCS-FS--1000-23 (S or AL)-83-10	Steel	20'	46	15	18-1/8	22-1/8	14-1/8	7-7/8	31	24'-6"	11'-11-5/8"	4	5	
	10'	AL-FS-1000-23-83-10	Alum	20'	46	15	22-1/8	-	13-1/8	7-7/8	31	24'-6"	12'-3-5/8"	4	5	
	12'	GLCS-FS--1000-23 (S or AL)-83-12	Steel	20'	46	15	18-1/8	22-1/8	14-1/8	7-7/8	31	24'-6"	13'-11-5/8"	4	5	
	12'	AL-FS-1000-23-83-12	Alum	20'	46	15	22-1/8	-	13-1/8	7-7/8	31	24'-6"	14'-3-5/8"	4	5	
94'	12'	GLCS-FS--1000-23 (S or AL)-83-14	Steel	20'	46	15	18-1/8	22-1/8	14-1/8	7-7/8	31	24'-8"	15'-11-5/8"	5	5	
	14'	AL-FS-1000-23-83-14	Alum	20'	46	15	22-1/8	-	13-1/8	7-7/8	31	24'-8"	16'-3-5/8"	5	5	
	10'	GLCSLX-FS--1000-23 (S or AL)-94-10	Steel	30'	54	15	24-1/8	28-1/8	14-1/8	7-7/8	31	24'-6"	12'-5-5/8"	4	4	
	12'	GLCSLX-FS--1000-23 (S or AL)-94-12	Steel	30'	54	15	24-1/8	28-1/8	14-1/8	7-7/8	31	24'-6"	14'-5-5/8"	4	4	
103'	14'	GLCSLX-FS--1000-23 (S or AL)-94-14	Steel	30'	54	15	24-1/8	28-1/8	14-1/8	7-7/8	31	24'-8"	16'-5-5/8"	5	4	
	10'	GLCS-FS--1000-23 (S or AL)-103-10	Steel	20'	54	15	18-1/8	22-1/8	14-1/8	7-7/8	31	24'-6"	11'-11-5/8"	4	6	
	10'	AL-FS-1000-23-103-10	Alum	20'	54	15	22-1/8	-	13-1/8	7-7/8	31	24'-6"	12'-3-5/8"	4	6	
	12'	GLCSL-FS--1000-23 (S or AL)-103-10	Steel	25'	54	15	21	25	14-1/8	7-7/8	31	24'-6"	12'-2-1/2"	4	5	
	12'	GLCS-FS--1000-23 (S or AL)-103-12	Steel	20'	54	15	18-1/8	22-1/8	14-1/8	7-7/8	31	24'-6"	13'-11-5/8"	4	6	
	12'	AL-FS-1000-23-103-12	Alum	20'	54	15	22-1/8	-	13-1/8	7-7/8	31	24'-6"	14'-3-5/8"	4	6	
	12'	GLCSL-FS--1000-23 (S or AL)-103-12	Steel	25'	54	15	21	25	14-1/8	7-7/8	31	24'-6"	14'-2-1/2"	4	5	
	14'	GLCS-FS--1000-23 (S or AL)-103-14	Steel	20'	54	15	18-1/8	22-1/8	14-1/8	7-7/8	31	24'-8"	15'-11-5/8"	5	6	
124'	14'	AL-FS-1000-23-103-14	Alum	20'	54	15	22-1/8	-	13-1/8	7-7/8	31	24'-8"	16'-3-5/8"	5	6	
	10'	GLCSLX-FS--1000-23 (S or AL)-124-10	Steel	30'	54	15	24-1/8	28-1/8	14-1/8	7-7/8	31	24'-6"	12'-5-5/8"	4	5	
	12'	GLCSLX-FS--1000-23 (S or AL)-124-12	Steel	30'	54	15	24-1/8	28-1/8	14-1/8	7-7/8	31	24'-6"	14'-5-5/8"	4	5	
14'	GLCSLX-FS--1000-23 (S or AL)-124-14	Steel	30'	54	15	24-1/8	28-1/8	14-1/8	7-7/8	31	24'-8"	16'-5-5/8"	5	5		

*This column provides the total number of support assemblies based on the "L1" dimensions shown. Support assemblies are designed to AISC specifications and do not require bracing. If no movement of the support assembly is preferred, then bracing to the building steel is recommended (not included).
To Determine Hook Coverage: [Bridge Travel on Runway = Runway Length - (2xL8)] by [Hoist Trolley Travel on Bridge = Bridge Length - L3 - L6] (L6 allows for festoon stack-up).
Gorbel Free Standing Work Station Bridge Crane kits include: bridge, runways, the appropriate number of support assemblies, hoist trolley, end trucks, end stops, flat wire festooning, festoon gliders (festoon trolleys on steel runway lengths greater than 63' and all aluminum systems), festoon stack-up section, splice joints and hanger brackets. Hoist and anchor bolts provided by others.
Dimensions are for reference only and are subject to change without notice.

FREE STANDING WORK STATION BRIDGE CRANES

BRIDGE LENGTH (L)	RUNWAY LENGTH	TS	MODEL NUMBER	TRACK MAT.	RUNWAY			BRIDGE						SUPPORT			
					MAX L1	L7 in	L8 in	H3 in	H3A in	H4 in	L3 in	L6 in	OAW	OAH	D in	#As	
28'	23'	10'	GLCS-FS-1000-28 (S or AL)-23-10	Steel	20'	9	2-1/8	20-1/2	23-3/4	17	7-7/8	33-3/8	29'-6"	12'-1"	4	2	
		10'	AL-FS-1000-28-23-10	Alum	20'	13	21	23-5/8	-	15-1/4	7-7/8	37-3/4	29'-6"	12'-5-1/8"	4	2	
		12'	GLCS-FS-1000-28 (S or AL)-23-12	Steel	20'	9	21-1/8	20-1/2	23-3/4	17	7-7/8	33-3/8	29'-6"	14'-1"	4	2	
		12'	AL-FS-1000-28-23-12	Alum	20'	13	21	23-5/8	-	15-1/4	7-7/8	37-3/4	29'-6"	14'-5-1/8"	4	2	
	14'	GLCS-FS-1000-28 (S or AL)-23-14	Steel	20'	9	21-1/8	20-1/2	23-3/4	17	7-7/8	33-3/8	29'-8"	16'-1"	5	2		
	14'	AL-FS-1000-28-23-14	Alum	20'	13	21	23-5/8	-	15-1/4	7-7/8	37-3/4	29'-8"	16'-5-1/8"	5	2		
	10'	GLCSL-FS-1000-28 (S or AL)-28-10	Steel	25'	9	21-1/8	23-3/8	26-5/8	17	7-7/8	33-3/8	29'-6"	12'-5-7/8"	4	2		
	12'	GLCSL-FS-1000-28 (S or AL)-28-12	Steel	25'	9	21-1/8	23-3/8	26-5/8	17	7-7/8	33-3/8	29'-6"	14'-5-7/8"	4	2		
	14'	GLCSL-FS-1000-28 (S or AL)-28-14	Steel	25'	9	21-1/8	23-3/8	26-5/8	17	7-7/8	33-3/8	29'-8"	16'-5-7/8"	5	2		
	10'	GLCS-FS-1000-28 (S or AL)-33-10	Steel	20'	9	21-1/8	20-1/2	23-3/4	17	7-7/8	33-3/8	29'-6"	12'-1"	4	3		
	10'	AL-FS-1000-28-33-10	Alum	20'	19	21	23-5/8	-	15-1/4	7-7/8	37-3/4	29'-6"	12'-5-1/8"	4	3		
	12'	GLCS-FS-1000-28 (S or AL)-33-12	Steel	20'	9	21-1/8	20-1/2	23-3/4	17	7-7/8	33-3/8	29'-6"	14'-1"	4	3		
12'	AL-FS-1000-28-33-12	Alum	20'	19	21	23-5/8	-	15-1/4	7-7/8	37-3/4	29'-6"	14'-5-1/8"	4	3			
14'	GLCS-FS-1000-28 (S or AL)-33-14	Steel	20'	9	21-1/8	20-1/2	23-3/4	17	7-7/8	33-3/8	29'-8"	16'-1"	5	3			
14'	AL-FS-1000-28-33-14	Alum	20'	19	21	23-5/8	-	15-1/4	7-7/8	37-3/4	29'-8"	16'-5-1/8"	5	3			
10'	GLCSLX-FS-1000-28 (S or AL)-34-10	Steel	30'	9	21-1/8	26-1/2	29-3/4	17	7-7/8	33-3/8	29'-6"	12'-8"	4	2			
12'	GLCSLX-FS-1000-28 (S or AL)-34-12	Steel	30'	9	21-1/8	26-1/2	29-3/4	17	7-7/8	33-3/8	29'-6"	14'-8"	4	2			
14'	GLCSLX-FS-1000-28 (S or AL)-34-14	Steel	30'	9	21-1/8	26-1/2	29-3/4	17	7-7/8	33-3/8	29'-8"	16'-8"	5	2			
10'	GLCS-FS-1000-28 (S or AL)-43-10	Steel	20'	13	21-1/8	20-1/2	23-3/4	17	7-7/8	33-3/8	29'-6"	12'-1"	4	3			
10'	AL-FS-1000-28-43-10	Alum	20'	26	21	23-5/8	-	15-1/4	7-7/8	37-3/4	29'-6"	12'-5-1/8"	4	3			
12'	GLCS-FS-1000-28 (S or AL)-43-12	Steel	20'	13	21-1/8	20-1/2	23-3/4	17	7-7/8	33-3/8	29'-6"	14'-1"	4	3			
12'	AL-FS-1000-28-43-12	Alum	20'	26	21	23-5/8	-	15-1/4	7-7/8	37-3/4	29'-6"	14'-5-1/8"	4	3			
14'	GLCS-FS-1000-28 (S or AL)-43-14	Steel	20'	13	21-1/8	20-1/2	23-3/4	17	7-7/8	33-3/8	29'-8"	16'-1"	5	3			
14'	AL-FS-1000-28-43-14	Alum	20'	26	21	23-5/8	-	15-1/4	7-7/8	37-3/4	29'-8"	16'-5-1/8"	5	3			
10'	GLCS-FS-1000-28 (S or AL)-53-10	Steel	20'	13	21-1/8	20-1/2	23-3/4	17	7-7/8	33-3/8	29'-6"	12'-1"	4	4			
10'	AL-FS-1000-28-53-10	Alum	20'	30	21	23-5/8	-	15-1/4	7-7/8	37-3/4	29'-6"	12'-5-1/8"	4	4			
12'	GLCSL-FS-1000-28 (S or AL)-53-10	Steel	25'	13	21-1/8	23-3/8	26-5/8	17	7-7/8	33-3/8	29'-6"	12'-5-7/8"	4	4			
12'	AL-FS-1000-28-53-12	Alum	20'	30	21	23-5/8	-	15-1/4	7-7/8	33-3/8	29'-6"	14'-1"	4	4			
12'	AL-FS-1000-28-53-12	Alum	20'	30	21	23-5/8	-	15-1/4	7-7/8	37-3/4	29'-6"	14'-5-1/8"	4	4			
12'	GLCSL-FS-1000-28 (S or AL)-53-12	Steel	25'	13	21-1/8	23-3/8	26-5/8	17	7-7/8	33-3/8	29'-6"	14'-5-7/8"	4	3			
14'	GLCS-FS-1000-28 (S or AL)-53-14	Steel	20'	13	21-1/8	20-1/2	23-3/4	17	7-7/8	33-3/8	29'-8"	16'-1"	5	4			
14'	AL-FS-1000-28-53-14	Alum	20'	30	21	23-5/8	-	15-1/4	7-7/8	37-3/4	29'-8"	16'-5-1/8"	5	4			
14'	GLCSL-FS-1000-28 (S or AL)-53-14	Steel	25'	13	21-1/8	23-3/8	26-5/8	17	7-7/8	33-3/8	29'-8"	16'-5-7/8"	5	3			
28'	63'	10'	GLCS-FS-1000-28 (S or AL)-63-10	Steel	20'	19	21-1/8	20-1/2	23-3/4	17	7-7/8	33-3/8	29'-6"	12'-1"	4	4	
		10'	AL-FS-1000-28-63-10	Alum	20'	36	21	23-5/8	-	15-1/4	7-7/8	37-3/4	29'-6"	12'-5-1/8"	4	4	
		12'	GLCS-FS-1000-28 (S or AL)-63-12	Steel	20'	19	21-1/8	20-1/2	23-3/4	17	7-7/8	33-3/8	29'-6"	14'-1"	4	4	
		12'	AL-FS-1000-28-63-12	Alum	20'	36	21	23-5/8	-	15-1/4	7-7/8	37-3/4	29'-6"	14'-5-1/8"	4	4	
	14'	GLCS-FS-1000-28 (S or AL)-63-14	Steel	20'	19	21-1/8	20-1/2	23-3/4	17	7-7/8	33-3/8	29'-8"	16'-1"	5	4		
	14'	AL-FS-1000-28-63-14	Alum	20'	36	21	23-5/8	-	15-1/4	7-7/8	37-3/4	29'-8"	16'-5-1/8"	5	4		
	10'	GLCSLX-FS-1000-28 (S or AL)-64-10	Steel	30'	36	21-1/8	26-1/2	29-3/4	17	7-7/8	37-3/4	29'-6"	12'-8"	4	3		
	12'	GLCSLX-FS-1000-28 (S or AL)-64-12	Steel	30'	36	21-1/8	26-1/2	29-3/4	17	7-7/8	37-3/4	29'-6"	14'-8"	4	3		
	14'	GLCSLX-FS-1000-28 (S or AL)-64-14	Steel	30'	36	21-1/8	26-1/2	29-3/4	17	7-7/8	37-3/4	29'-8"	16'-8"	5	3		
	10'	GLCSL-FS-1000-28 (S or AL)-78-10	Steel	25'	46	21-1/8	23-3/8	26-5/8	17	7-7/8	37-3/4	29'-6"	12'-5-7/8"	4	4		
	12'	GLCSL-FS-1000-28 (S or AL)-78-12	Steel	25'	46	21-1/8	23-3/8	26-5/8	17	7-7/8	37-3/4	29'-6"	14'-5-7/8"	4	4		
	14'	GLCSL-FS-1000-28 (S or AL)-78-14	Steel	25'	46	21-1/8	23-3/8	26-5/8	17	7-7/8	37-3/4	29'-8"	16'-5-7/8"	5	4		
10'	GLCS-FS-1000-28 (S or AL)-83-10	Steel	20'	46	21-1/8	20-1/2	23-3/4	17	7-7/8	37-3/4	29'-6"	12'-1"	4	5			
10'	AL-FS-1000-28-83-10	Alum	20'	46	21	23-5/8	-	15-1/4	7-7/8	37-3/4	29'-6"	12'-5-1/8"	4	5			
12'	GLCS-FS-1000-28 (S or AL)-83-12	Steel	20'	46	21-1/8	20-1/2	23-3/4	17	7-7/8	37-3/4	29'-6"	14'-1"	4	5			
12'	AL-FS-1000-28-83-12	Alum	20'	46	21	23-5/8	-	15-1/4	7-7/8	37-3/4	29'-6"	14'-5-1/8"	4	5			
14'	GLCS-FS-1000-28 (S or AL)-83-14	Steel	20'	46	21-1/8	20-1/2	23-3/4	17	7-7/8	37-3/4	29'-8"	16'-1"	5	5			
14'	AL-FS-1000-28-83-14	Alum	20'	46	21	23-5/8	-	15-1/4	7-7/8	37-3/4	29'-8"	16'-5-1/8"	5	5			
10'	GLCSLX-FS-1000-28 (S or AL)-94-10	Steel	30'	54	21-1/8	26-1/2	29-3/4	17	7-7/8	37-3/4	29'-6"	12'-8"	4	4			
12'	GLCSLX-FS-1000-28 (S or AL)-94-12	Steel	30'	54	21-1/8	26-1/2	29-3/4	17	7-7/8	37-3/4	29'-6"	14'-8"	4	4			
14'	GLCSLX-FS-1000-28 (S or AL)-94-14	Steel	30'	54	21-1/8	26-1/2	29-3/4	17	7-7/8	37-3/4	29'-8"	16'-8"	5	4			
10'	GLCS-FS-1000-28 (S or AL)-103-10	Steel	20'	54	21-1/8	20-1/2	23-3/4	17	7-7/8	37-3/4	29'-6"	12'-1"	4	6			
10'	AL-FS-1000-28-103-10	Alum	20'	54	21	23-5/8	-	15-1/4	7-7/8	37-3/4	29'-6"	12'-5-1/8"	4	6			
12'	GLCSL-FS-1000-28 (S or AL)-103-10	Steel	25'	54	21-1/8	23-3/8	26-5/8	17	7-7/8	37-3/4	29'-6"	12'-5-7/8"	4	5			
12'	GLCS-FS-1000-28 (S or AL)-103-12	Steel	20'	54	21-1/8	20-1/2	23-3/4	17	7-7/8	37-3/4	29'-6"	14'-1"	4	6			
12'	AL-FS-1000-28-103-12	Alum	20'	54	21	23-5/8	-	15-1/4	7-7/8	37-3/4	29'-6"	14'-5-1/8"	4	6			
14'	GLCSL-FS-1000-28 (S or AL)-103-12	Steel	25'	54	21-1/8	23-3/8	26-5/8	17	7-7/8	37-3/4	29'-6"	14'-5-7/8"	4	5			
14'	GLCS-FS-1000-28 (S or AL)-103-14	Steel	20'	54	21-1/8	20-1/2	23-3/4	17	7-7/8	37-3/4	29'-8"	16'-1"	5	6			
14'	AL-FS-1000-28-103-14	Alum	20'	54	21	23-5/8	-	15-1/4	7-7/8	37-3/4	29'-8"	16'-5-1/8"	5	6			
14'	GLCSL-FS-1000-28 (S or AL)-103-14	Steel	25'	54	21-1/8	23-3/8	26-5/8	17	7-7/8	37-3/4	29'-8"	16'-5-7/8"	5	5			
124'	102'	10'	GLCSLX-FS-1000-28 (S or AL)-124-10	Steel	30'	54	21-1/8	26-1/2	29-3/4	17	7-7/8	37-3/4	29'-6"	12'-8"	4	5	
		12'	GLCSLX-FS-1000-28 (S or AL)-124-12	Steel	30'	54	21-1/8	26-1/2	29-3/4	17	7-7/8	37-3/4	29'-6"	14'-8"	4	5	
		14'	GLCSLX-FS-1000-28 (S or AL)-124-14	Steel	30'	54	21-1/8	26-1/2	29-3/4	17	7-7/8	37-3/4	29'-8"	16'-8"	5	5	

*This column provides the total number of support assemblies based on the "L1" dimensions shown. Support assemblies are designed to AISC specifications and do not require bracing. If no movement of the support assembly is preferred, then bracing to the building steel is recommended (not included).
To Determine Hook Coverage: [Bridge Travel on Runway = Runway Length - (2xL8)] by [Hoist Trolley Travel on Bridge = Bridge Length - L3 - L6] (L6 allows for festoon stack-up).
GORBEL Free Standing Work Station Bridge Crane kits include: bridge, runways, the appropriate number of support assemblies, hoist trolley, end trucks, end stops, flat wire festooning, festoon gliders (festoon trolleys on steel runway lengths greater than 63' and all aluminum systems), festoon stack-up section, splice joints and hanger brackets. Hoist and anchor bolts provided by others.
Dimensions are for reference only and are subject to change without notice.

FREE STANDING WORK STATION BRIDGE CRANES

BRIDGE LENGTH (L)	RUNWAY LENGTH	TS	MODEL NUMBER	TRACK MAT.	RUNWAY			BRIDGE				SUPPORT				
					MAX L1	L7 in	L8 in	H3 in	H3A in	H4 in	L3 in	L6 in	OAW	OAH	D in	H in
34'	28'	10'	GLCSL-FS-1000-34 (S or AL)-28-10	Steel	25'	13	21-7/8	23-3/8	26-5/8	20-1/8	7-7/8	39-3/8	35'-6"	12'-6-7/8"	4	2
		12'	GLCSL-FS-1000-34 (S or AL)-28-12	Steel	25'	13	21-7/8	23-3/8	26-5/8	20-1/8	7-7/8	39-3/8	35'-6"	14'-6-7/8"	4	2
		14'	GLCSL-FS-1000-34 (S or AL)-28-14	Steel	25'	13	21-7/8	23-3/8	26-5/8	20-1/8	7-7/8	39-3/8	35'-6"	16'-6-7/8"	5	2
	33'	10'	GLCS-FS-1000-34 (S or AL)-33-10	Steel	20'	9	21-7/8	23-1/2	23-3/4	20-1/8	7-7/8	39-3/8	35'-6"	12'-6"	4	3
		12'	AL-FS-1000-34-33-10	Alum	20'	19	21	23-5/8	-	16-3/4	7-7/8	44-1/2	35'-6"	12'-7-1/8"	4	3
		14'	GLCS-FS-1000-34 (S or AL)-33-12	Steel	20'	9	21-7/8	23-1/2	23-3/4	20-1/8	7-7/8	39-3/8	35'-6"	14'-6"	4	3
	34'	10'	AL-FS-1000-34-33-12	Alum	20'	19	21	23-5/8	-	16-3/4	7-7/8	44-1/2	35'-6"	14'-7-1/8"	4	3
		12'	GLCS-FS-1000-34 (S or AL)-33-14	Steel	20'	9	21-7/8	23-1/2	23-3/4	20-1/8	7-7/8	39-3/8	35'-8"	16'-6"	5	3
		14'	AL-FS-1000-34-33-14	Alum	20'	19	21	23-5/8	-	16-3/4	7-7/8	44-1/2	35'-8"	16'-7-1/8"	5	3
	34'	10'	GLCSLX-FS-1000-34 (S or AL)-34-10	Steel	30'	9	21-7/8	26-1/2	29-3/4	20-1/8	7-7/8	39-3/8	35'-6"	12'-9"	4	2
		12'	GLCSLX-FS-1000-34 (S or AL)-34-12	Steel	30'	9	21-7/8	26-1/2	29-3/4	20-1/8	7-7/8	39-3/8	35'-6"	14'-9"	4	2
		14'	GLCSLX-FS-1000-34 (S or AL)-34-14	Steel	30'	9	21-7/8	26-1/2	29-3/4	20-1/8	7-7/8	39-3/8	35'-8"	16'-9"	5	2
	43'	10'	GLCS-FS-1000-34 (S or AL)-43-10	Steel	20'	13	21-7/8	23-1/2	23-3/4	20-1/8	7-7/8	39-3/8	35'-6"	12'-6"	4	3
		12'	AL-FS-1000-34-43-10	Alum	20'	26	21	23-5/8	-	16-3/4	7-7/8	44-1/2	35'-6"	12'-7-1/8"	4	3
		14'	GLCS-FS-1000-34 (S or AL)-43-12	Steel	20'	13	21-7/8	23-1/2	23-3/4	20-1/8	7-7/8	39-3/8	35'-6"	14'-6"	4	3
	43'	10'	AL-FS-1000-34-43-12	Alum	20'	26	21	23-5/8	-	16-3/4	7-7/8	44-1/2	35'-6"	14'-7-1/8"	4	3
		12'	GLCS-FS-1000-34 (S or AL)-43-14	Steel	20'	13	21-7/8	23-1/2	23-3/4	20-1/8	7-7/8	39-3/8	35'-8"	16'-6"	5	3
		14'	AL-FS-1000-34-43-14	Alum	20'	26	21	23-5/8	-	16-3/4	7-7/8	44-1/2	35'-8"	16'-7-1/8"	5	3
	53'	10'	GLCS-FS-1000-34 (S or AL)-53-10	Steel	20'	13	21-7/8	23-1/2	23-3/4	20-1/8	7-7/8	39-3/8	35'-6"	12'-6"	4	4
		12'	AL-FS-1000-34-53-10	Alum	20'	30	21	23-5/8	-	16-3/4	7-7/8	44-1/2	35'-6"	12'-7-1/8"	4	4
		14'	GLCSL-FS-1000-34 (S or AL)-53-10	Steel	25'	13	21-7/8	23-3/8	26-5/8	20-1/8	7-7/8	39-3/8	35'-6"	12'-6-7/8"	4	3
	53'	10'	GLCS-FS-1000-34 (S or AL)-53-12	Steel	20'	13	21-7/8	23-1/2	23-3/4	20-1/8	7-7/8	39-3/8	35'-6"	14'-6"	4	4
		12'	AL-FS-1000-34-53-12	Alum	20'	30	21	23-5/8	-	16-3/4	7-7/8	44-1/2	35'-6"	14'-7-1/8"	4	4
		14'	GLCSL-FS-1000-34 (S or AL)-53-12	Steel	25'	13	21-7/8	23-3/8	26-5/8	20-1/8	7-7/8	39-3/8	35'-6"	14'-6-7/8"	4	3
	53'	10'	GLCS-FS-1000-34 (S or AL)-53-14	Steel	20'	13	21-7/8	23-1/2	23-3/4	20-1/8	7-7/8	39-3/8	35'-8"	16'-6"	5	4
		12'	AL-FS-1000-34-53-14	Alum	20'	30	21	23-5/8	-	16-3/4	7-7/8	44-1/2	35'-8"	16'-7-1/8"	5	4
		14'	GLCSL-FS-1000-34 (S or AL)-53-14	Steel	25'	13	21-7/8	23-3/8	26-5/8	20-1/8	7-7/8	39-3/8	35'-8"	16'-6-7/8"	5	3
	63'	10'	GLCS-FS-1000-34 (S or AL)-63-10	Steel	20'	19	21-7/8	23-1/2	23-3/4	20-1/8	7-7/8	39-3/8	35'-6"	12'-6"	4	4
		12'	AL-FS-1000-34-63-10	Alum	20'	36	21	23-5/8	-	16-3/4	7-7/8	44-1/2	35'-6"	12'-7-1/8"	4	4
		14'	GLCS-FS-1000-34 (S or AL)-63-12	Steel	20'	19	21-7/8	23-1/2	23-3/4	20-1/8	7-7/8	39-3/8	35'-6"	14'-6"	4	4
	63'	10'	AL-FS-1000-34-63-12	Alum	20'	36	21	23-5/8	-	16-3/4	7-7/8	44-1/2	35'-6"	14'-7-1/8"	4	4
		12'	GLCS-FS-1000-34 (S or AL)-63-14	Steel	20'	19	21-7/8	23-1/2	23-3/4	20-1/8	7-7/8	39-3/8	35'-8"	16'-6"	5	4
		14'	AL-FS-1000-34-63-14	Alum	20'	36	21	23-5/8	-	16-3/4	7-7/8	44-1/2	35'-8"	16'-7-1/8"	5	4
	64'	10'	GLCSLX-FS-1000-34 (S or AL)-64-10	Steel	30'	36	21-7/8	26-1/2	29-3/4	20-1/8	7-7/8	44-1/2	35'-6"	12'-9"	4	3
		12'	GLCSLX-FS-1000-34 (S or AL)-64-12	Steel	30'	36	21-7/8	26-1/2	29-3/4	20-1/8	7-7/8	44-1/2	35'-6"	14'-9"	4	3
		14'	GLCSLX-FS-1000-34 (S or AL)-64-14	Steel	30'	36	21-7/8	26-1/2	29-3/4	20-1/8	7-7/8	44-1/2	35'-8"	16'-9"	5	3
	78'	10'	GLCSL-FS-1000-34 (S or AL)-78-10	Steel	25'	46	21-7/8	23-3/8	26-5/8	20-1/8	7-7/8	44-1/2	35'-6"	12'-6-7/8"	4	4
		12'	GLCSL-FS-1000-34 (S or AL)-78-12	Steel	25'	46	21-7/8	23-3/8	26-5/8	20-1/8	7-7/8	44-1/2	35'-6"	14'-6-7/8"	4	4
		14'	GLCSL-FS-1000-34 (S or AL)-78-14	Steel	25'	46	21-7/8	23-3/8	26-5/8	20-1/8	7-7/8	44-1/2	35'-8"	16'-6-7/8"	5	4
	83'	10'	GLCS-FS-1000-34 (S or AL)-83-10	Steel	20'	46	21-7/8	23-1/2	23-3/4	20-1/8	7-7/8	44-1/2	35'-6"	12'-6"	4	5
		12'	AL-FS-1000-34-83-10	Alum	20'	46	21	23-5/8	-	16-3/4	7-7/8	44-1/2	35'-6"	12'-7-1/8"	4	5
		14'	GLCS-FS-1000-34 (S or AL)-83-12	Steel	20'	46	21-7/8	23-1/2	23-3/4	20-1/8	7-7/8	44-1/2	35'-6"	14'-6"	4	5
	83'	10'	AL-FS-1000-34-83-12	Alum	20'	46	21	23-5/8	-	16-3/4	7-7/8	44-1/2	35'-6"	14'-7-1/8"	4	5
		12'	GLCS-FS-1000-34 (S or AL)-83-14	Steel	20'	46	21-7/8	23-1/2	23-3/4	20-1/8	7-7/8	44-1/2	35'-8"	16'-6"	5	5
		14'	AL-FS-1000-34-83-14	Alum	20'	46	21	23-5/8	-	16-3/4	7-7/8	44-1/2	35'-8"	16'-7-1/8"	5	5
	94'	10'	GLCSLX-FS-1000-34 (S or AL)-94-10	Steel	30'	54	21-7/8	26-1/2	29-3/4	20-1/8	7-7/8	44-1/2	35'-6"	12'-9"	4	4
		12'	GLCSLX-FS-1000-34 (S or AL)-94-12	Steel	30'	54	21-7/8	26-1/2	29-3/4	20-1/8	7-7/8	44-1/2	35'-6"	14'-9"	4	4
		14'	GLCSLX-FS-1000-34 (S or AL)-94-14	Steel	30'	54	21-7/8	26-1/2	29-3/4	20-1/8	7-7/8	44-1/2	35'-8"	16'-9"	5	4
	103'	10'	GLCS-FS-1000-34 (S or AL)-103-10	Steel	20'	54	21-7/8	23-1/2	23-3/4	20-1/8	7-7/8	44-1/2	35'-6"	12'-6"	4	6
		12'	AL-FS-1000-34-103-10	Alum	20'	54	21	23-5/8	-	16-3/4	7-7/8	44-1/2	35'-6"	12'-7-1/8"	4	6
		14'	GLCSL-FS-1000-34 (S or AL)-103-10	Steel	25'	54	21-7/8	23-3/8	26-5/8	20-1/8	7-7/8	44-1/2	35'-6"	12'-6-7/8"	4	5
	103'	10'	GLCS-FS-1000-34 (S or AL)-103-12	Steel	20'	54	21-7/8	23-1/2	23-3/4	20-1/8	7-7/8	44-1/2	35'-6"	14'-6"	4	6
		12'	AL-FS-1000-34-103-12	Alum	20'	54	21	23-5/8	-	16-3/4	7-7/8	44-1/2	35'-6"	14'-7-1/8"	4	6
		14'	GLCSL-FS-1000-34 (S or AL)-103-12	Steel	25'	54	21-7/8	23-3/8	26-5/8	20-1/8	7-7/8	44-1/2	35'-6"	14'-6-7/8"	4	5
	103'	10'	GLCS-FS-1000-34 (S or AL)-103-14	Steel	20'	54	21-7/8	23-1/2	23-3/4	20-1/8	7-7/8	44-1/2	35'-8"	16'-6"	5	6
		12'	AL-FS-1000-34-103-14	Alum	20'	54	21	23-5/8	-	16-3/4	7-7/8	44-1/2	35'-8"	16'-7-1/8"	5	6
		14'	GLCSL-FS-1000-34 (S or AL)-103-14	Steel	25'	54	21-7/8	23-3/8	26-5/8	20-1/8	7-7/8	44-1/2	35'-8"	16'-6-7/8"	5	5
	124'	10'	GLCSLX-FS-1000-34 (S or AL)-124-10	Steel	30'	54	21-7/8	26-1/2	29-3/4	20-1/8	7-7/8	44-1/2	35'-6"	12'-9"	4	5
		12'	GLCSLX-FS-1000-34 (S or AL)-124-12	Steel	30'	54	21-7/8	26-1/2	29-3/4	20-1/8	7-7/8	44-1/2	35'-6"	14'-9"	4	5
		14'	GLCSLX-FS-1000-34 (S or AL)-124-14	Steel	30'	54	21-7/8	26-1/2	29-3/4	20-1/8	7-7/8	44-1/2	35'-8"	16'-9"	5	5

*This column provides the total number of support assemblies based on the "L1" dimensions shown. Support assemblies are designed to AISC specifications and do not require bracing. If no movement of the support assembly is preferred, then bracing to the building steel is recommended (not included).
 To Determine Hook Coverage: [Bridge Travel on Runway = Runway Length - (2xL8)] by [Hoist Trolley Travel on Bridge = Bridge Length - L3 - L6] (L6 allows for festoon stack-up).
 Gorbel Free Standing Work Station Bridge Crane kits include: bridge, runways, the appropriate number of support assemblies, hoist trolleys, end trucks, end stops, flat wire festooning, festoon gliders (festoon trolleys on steel runway lengths greater than 63' and all aluminum systems), festoon stack-up section, splice joints and hanger brackets. Hoist and anchor bolts provided by others.
 Dimensions are for reference only and are subject to change without notice.

FREE STANDING WORK STATION BRIDGE CRANES

BRIDGE LENGTH (L)	RUNWAY LENGTH	TS	MODEL NUMBER	TRACK MAT.	RUNWAY			BRIDGE				SUPPORT STRUCTURE				
					MAX. L1	L7 in	L8 in	H3 in	H3A in	H4 in	L3 in	L6 in	OAW	OAH	D in	Spt.
10'	11' 6"	10'	GLCS-FS-2000-10 (S or AL)-11.5-10	Steel	20'	9	16-1/8	19-5/8	24	8-1/8	8-1/8	24	11'-8"	12'-0-1/8"	5	2
		12'	GLCS-FS-2000-10 (S or AL)-11.5-12	Steel	20'	9	16-1/8	19-5/8	24	8-1/8	8-1/8	24	11'-8"	14'-0-1/8"	5	2
		14'	GLCS-FS-2000-10 (S or AL)-11.5-14	Steel	20'	9	16-1/8	19-5/8	24	8-1/8	8-1/8	24	11'-8"	16'-1-1/8"	5	2
	23'	10'	GLCS-FS-2000-10 (S or AL)-23-10	Steel	20'	9	16-1/8	19-5/8	24	8-7/8	8-1/8	24	11'-8"	12'-0-1/8"	5	2
		10'	AL-FS-2000-10-23-10	Alum	20'	13	17	25-1/4	-	13-3/8	8	17-5/8	11'-8"	12'-5-3/4"	5	2
		12'	GLCSL-FS-2000-10 (S or AL)-23-12	Steel	20'	9	16-1/8	19-5/8	24	8-7/8	8-1/8	24	11'-8"	14'-0-1/8"	5	2
		12'	AL-FS-2000-10-23-12	Alum	20'	13	17	25-1/4	-	13-3/8	8	17-5/8	11'-8"	14'-5-3/4"	5	2
		14'	GLCSL-FS-2000-10 (S or AL)-23-14	Steel	20'	9	16-1/8	19-5/8	24	8-7/8	8-1/8	24	11'-8"	16'-1-1/8"	5	2
		14'	AL-FS-2000-10-23-14	Alum	20'	13	17	25-1/4	-	13-3/8	8	17-5/8	11'-8"	16'-6-3/4"	5	2
	28'	10'	GLCSL-FS-2000-10 (S or AL)-28-10	Steel	25'	13	16-1/8	23	27-3/8	8-7/8	8-1/8	24	11'-8"	12'-4-1/2"	5	2
		12'	GLCSL-FS-2000-10 (S or AL)-28-12	Steel	25'	13	16-1/8	23	27-3/8	8-7/8	8-1/8	24	11'-8"	14'-4-1/2"	5	2
		14'	GLCSL-FS-2000-10 (S or AL)-28-14	Steel	25'	13	16-1/8	23	27-3/8	8-7/8	8-1/8	24	11'-8"	16'-4-1/2"	5	2
	33'	10'	GLCS-FS-2000-10 (S or AL)-33-10	Steel	20'	13	16-1/8	19-5/8	24	8-7/8	8-1/8	24	11'-8"	12'-0-1/8"	5	3
		10'	AL-FS-2000-10-33-10	Alum	20'	19	17	25-1/4	-	13-3/8	8	17-5/8	11'-8"	12'-5-3/4"	5	3
		12'	GLCSL-FS-2000-10 (S or AL)-33-12	Steel	20'	13	16-1/8	19-5/8	24	8-7/8	8-1/8	24	11'-8"	14'-0-1/8"	5	3
		12'	AL-FS-2000-10-33-12	Alum	20'	19	17	25-1/4	-	13-3/8	8	17-5/8	11'-8"	14'-5-3/4"	5	3
		14'	GLCSL-FS-2000-10 (S or AL)-33-14	Steel	20'	13	16-1/8	19-5/8	24	8-7/8	8-1/8	24	11'-8"	16'-1-1/8"	5	3
		14'	AL-FS-2000-10-33-14	Alum	20'	19	17	25-1/4	-	13-3/8	8	17-5/8	11'-8"	16'-6-3/4"	5	3
	34'	10'	GLCSLX-FS-2000-10 (S or AL)-34-10	Steel	30'	13	16-1/8	25-5/8	30	8-7/8	8-1/8	24	11'-8"	12'-7-1/8"	5	2
		12'	GLCSLX-FS-2000-10 (S or AL)-34-12	Steel	30'	13	16-1/8	25-5/8	30	8-7/8	8-1/8	24	11'-8"	14'-7-1/8"	5	2
		14'	GLCSLX-FS-2000-10 (S or AL)-34-14	Steel	30'	13	16-1/8	25-5/8	30	8-7/8	8-1/8	24	11'-8"	16'-7-1/8"	5	2
	43'	10'	GLCS-FS-2000-10 (S or AL)-43-10	Steel	20'	19	16-1/8	19-5/8	24	8-7/8	8-1/8	24	11'-8"	12'-0-1/8"	5	3
		10'	AL-FS-2000-10-43-10	Alum	20'	26	17	25-1/4	-	13-3/8	8	17-5/8	11'-8"	12'-5-3/4"	5	3
		12'	GLCSL-FS-2000-10 (S or AL)-43-12	Steel	20'	19	16-1/8	19-5/8	24	8-7/8	8-1/8	24	11'-8"	14'-0-1/8"	5	3
		12'	AL-FS-2000-10-43-12	Alum	20'	26	17	25-1/4	-	13-3/8	8	17-5/8	11'-8"	14'-5-3/4"	5	3
		14'	GLCSL-FS-2000-10 (S or AL)-43-14	Steel	20'	19	16-1/8	19-5/8	24	8-7/8	8-1/8	24	11'-8"	16'-1-1/8"	5	3
		14'	AL-FS-2000-10-43-14	Alum	20'	26	17	25-1/4	-	13-3/8	8	17-5/8	11'-8"	16'-6-3/4"	5	3
	53'	10'	GLCS-FS-2000-10 (S or AL)-53-10	Steel	20'	19	16-1/8	19-5/8	24	8-7/8	8-1/8	24	11'-8"	12'-0-1/8"	5	4
		10'	AL-FS-2000-10 (S or AL)-53-10	Alum	20'	30	17	25-1/4	-	13-3/8	8	17-5/8	11'-8"	12'-5-3/4"	5	4
		12'	GLCSL-FS-2000-10 (S or AL)-53-12	Steel	25'	19	16-1/8	23	27-3/8	8-7/8	8-1/8	24	11'-8"	12'-4-1/2"	5	4
		12'	AL-FS-2000-10-53-12	Alum	20'	30	17	25-1/4	-	13-3/8	8	17-5/8	11'-8"	14'-5-3/4"	5	4
		14'	GLCSL-FS-2000-10 (S or AL)-53-14	Steel	20'	19	16-1/8	19-5/8	24	8-7/8	8-1/8	24	11'-8"	16'-1-1/8"	5	4
		14'	AL-FS-2000-10-53-14	Alum	20'	30	17	25-1/4	-	13-3/8	8	17-5/8	11'-8"	16'-6-3/4"	5	4
	63'	10'	GLCS-FS-2000-10 (S or AL)-63-10	Steel	20'	26	16-1/8	19-5/8	24	8-7/8	8-1/8	24	11'-8"	12'-0-1/8"	5	4
		10'	AL-FS-2000-10-63-10	Alum	20'	36	17	25-1/4	-	13-3/8	8	17-5/8	11'-8"	12'-5-3/4"	5	4
		12'	GLCSL-FS-2000-10 (S or AL)-63-12	Steel	20'	26	16-1/8	19-5/8	24	8-7/8	8-1/8	24	11'-8"	14'-0-1/8"	5	4
		12'	AL-FS-2000-10-63-12	Alum	20'	36	17	25-1/4	-	13-3/8	8	17-5/8	11'-8"	14'-5-3/4"	5	4
		14'	GLCSL-FS-2000-10 (S or AL)-63-14	Steel	20'	26	16-1/8	19-5/8	24	8-7/8	8-1/8	24	11'-8"	16'-1-1/8"	5	4
		14'	AL-FS-2000-10-63-14	Alum	20'	36	17	25-1/4	-	13-3/8	8	17-5/8	11'-8"	16'-6-3/4"	5	4
	64'	10'	GLCSLX-FS-2000-10 (S or AL)-64-10	Steel	30'	36	16-1/8	25-5/8	30	8-7/8	8-1/8	24	11'-8"	12'-7-1/8"	5	3
		12'	GLCSLX-FS-2000-10 (S or AL)-64-12	Steel	30'	36	16-1/8	25-5/8	30	8-7/8	8-1/8	24	11'-8"	14'-7-1/8"	5	3
		14'	GLCSLX-FS-2000-10 (S or AL)-64-14	Steel	30'	36	16-1/8	25-5/8	30	8-7/8	8-1/8	24	11'-8"	16'-7-1/8"	5	3
	78'	10'	GLCSL-FS-2000-10 (S or AL)-78-10	Steel	25'	46	16-1/8	23	27-3/8	8-7/8	8-1/8	24	11'-8"	12'-4-1/2"	5	4
		12'	GLCSL-FS-2000-10 (S or AL)-78-12	Steel	25'	46	16-1/8	23	27-3/8	8-7/8	8-1/8	24	11'-8"	14'-4-1/2"	5	4
		14'	GLCSL-FS-2000-10 (S or AL)-78-14	Steel	25'	46	16-1/8	23	27-3/8	8-7/8	8-1/8	24	11'-8"	16'-4-1/2"	5	4
	83'	10'	GLCS-FS-2000-10 (S or AL)-83-10	Steel	20'	46	16-1/8	19-5/8	24	8-7/8	8-1/8	24	11'-8"	12'-0-1/8"	5	5
		10'	AL-FS-2000-10-83-10	Alum	20'	46	17	25-1/4	-	13-3/8	8	17-5/8	11'-8"	12'-5-3/4"	5	5
		12'	GLCSL-FS-2000-10 (S or AL)-83-12	Steel	20'	46	16-1/8	19-5/8	24	8-7/8	8-1/8	24	11'-8"	14'-0-1/8"	5	5
		12'	AL-FS-2000-10-83-12	Alum	20'	46	17	25-1/4	-	13-3/8	8	17-5/8	11'-8"	14'-5-3/4"	5	5
		14'	GLCSL-FS-2000-10 (S or AL)-83-14	Steel	20'	46	16-1/8	19-5/8	24	8-7/8	8-1/8	24	11'-8"	16'-1-1/8"	5	5
		14'	AL-FS-2000-10-83-14	Alum	20'	46	17	25-1/4	-	13-3/8	8	17-5/8	11'-8"	16'-6-3/4"	5	5
	94'	10'	GLCSLX-FS-2000-10 (S or AL)-94-10	Steel	30'	54	16-1/8	25-5/8	30	8-7/8	8-1/8	24	11'-8"	12'-7-1/8"	5	4
		12'	GLCSLX-FS-2000-10 (S or AL)-94-12	Steel	30'	54	16-1/8	25-5/8	30	8-7/8	8-1/8	24	11'-8"	14'-7-1/8"	5	4
		14'	GLCSLX-FS-2000-10 (S or AL)-94-14	Steel	30'	54	16-1/8	25-5/8	30	8-7/8	8-1/8	24	11'-8"	16'-7-1/8"	5	4
	103'	10'	GLCS-FS-2000-10 (S or AL)-103-10	Steel	20'	54	16-1/8	19-5/8	24	8-7/8	8-1/8	24	11'-8"	12'-0-1/8"	5	6
		10'	AL-FS-2000-10-83-10	Alum	20'	54	17	25-1/4	-	13-3/8	8	17-5/8	11'-8"	12'-5-3/4"	5	6
		12'	GLCSL-FS-2000-10 (S or AL)-103-12	Steel	25'	54	16-1/8	23	27-3/8	8-7/8	8-1/8	24	11'-8"	12'-4-1/2"	5	6
		12'	AL-FS-2000-10-83-12	Alum	20'	54	17	25-1/4	-	13-3/8	8	17-5/8	11'-8"	14'-5-3/4"	5	6
		14'	GLCSL-FS-2000-10 (S or AL)-103-14	Steel	25'	54	16-1/8	23	27-3/8	8-7/8	8-1/8	24	11'-8"	14'-4-1/2"	5	6
		14'	AL-FS-2000-10-83-14	Alum	20'	54	17	25-1/4	-	13-3/8	8	17-5/8	11'-8"	16'-6-3/4"	5	6
	124'	10'	GLCSLX-FS-2000-10 (S or AL)-124-10	Steel	30'	54	16-1/8	25-5/8	30	8-7/8	8-1/8	24	11'-8"	12'-7-1/8"	5	5
		12'	GLCSLX-FS-2000-10 (S or AL)-124-12	Steel	30'	54	16-1/8	25-5/8	30	8-7/8	8-1/8	24	11'-8"	14'-7-1/8"	5	5
		14'	GLCSLX-FS-2000-10 (S or AL)-124-14	Steel	30'	54	16-1/8	25-5/8	30	8-7/8	8-1/8	24	11'-8"	16'-7-1/8"	5	5

*This column provides the total number of support assemblies based on the "L1" dimensions shown. Support assemblies are designed to AISC specifications and do not require bracing. If no movement of the support assembly is preferred, then bracing to the building steel is recommended (not included).
To Determine Hook Coverage: [Bridge Travel on Runway = Runway Length - (2xL8)] by [Hoist Trolley Travel on Bridge = Bridge Length - L3 - L6] (L6 allows for festoon stack-up).
Corbel Free Standing Work Station Bridge Crane kits include: bridge, runways, the appropriate number of support assemblies, hoist trolley, end trucks, end stops, flat wire festooning, festoon gliders (festoon trolleys on steel runway lengths greater than 63' and all aluminum systems), festoon stack-up section, splice joints and hanger brackets. Hoist and anchor bolts provided by others.
Dimensions are for reference only and are subject to change without notice.

FREE STANDING WORK STATION BRIDGE CRANES

BRIDGE LENGTH (L)	RUNWAY LENGTH	TS	MODEL NUMBER	TRACK MAT.	RUNWAY			BRIDGE					SUPPORT			
					MAX. L1	L7 in	L8 in	H3 in	H3A in	H4 in	L3 in	L6 in	OAW	OAH	D in	SPT.
15'	23'	10'	GLCS-FS-2000-15 (S or AL)-23-10	Steel	20'	9	16-1/8	19-5/8	24	14-7/8	8-1/8	24	16'-8"	12'-1-1/8"	5	2
		10'	AL-FS-2000-15-23-10	Alum	20'	13	17	25-1/4	-	13-3/8	8	24-3/8	16'-8"	12'-6-3/4"	5	2
		12'	GLCS-FS-2000-15 (S or AL)-23-12	Steel	20'	9	16-1/8	19-5/8	24	14-7/8	8-1/8	24	16'-8"	14'-1-1/8"	5	2
		12'	AL-FS-2000-15-23-12	Alum	20'	13	17	25-1/4	-	13-3/8	8	24-3/8	16'-8"	14'-6-3/4"	5	2
	28'	10'	GLCSL-FS-2000-15 (S or AL)-28-10	Steel	25'	13	16-1/8	23	27-3/8	14-7/8	8-1/8	24	16'-8"	12'-4-1/2"	5	2
		12'	GLCSL-FS-2000-15 (S or AL)-28-12	Steel	25'	13	16-1/8	23	27-3/8	14-7/8	8-1/8	24	16'-8"	14'-4-1/2"	5	2
		14'	GLCSL-FS-2000-15 (S or AL)-28-14	Steel	25'	13	16-1/8	23	27-3/8	14-7/8	8-1/8	24	16'-8"	16'-4-1/2"	5	2
		10'	AL-FS-2000-15-28-10	Alum	20'	13	17	25-1/4	-	13-3/8	8	24-3/8	16'-8"	16'-6-3/4"	5	2
	33'	10'	GLCS-FS-2000-15 (S or AL)-33-10	Steel	20'	13	16-1/8	19-5/8	24	14-7/8	8-1/8	24	16'-8"	12'-1-1/8"	5	3
		10'	AL-FS-2000-15-33-10	Alum	20'	19	17	25-1/4	-	13-3/8	8	24-3/8	16'-8"	12'-6-3/4"	5	3
		12'	GLCS-FS-2000-15 (S or AL)-33-12	Steel	20'	13	16-1/8	19-5/8	24	14-7/8	8-1/8	24	16'-8"	14'-1-1/8"	5	3
		12'	AL-FS-2000-15-33-12	Alum	20'	19	17	25-1/4	-	13-3/8	8	24-3/8	16'-8"	14'-6-3/4"	5	3
	34'	10'	GLCSLX-FS-2000-15 (S or AL)-34-10	Steel	30'	13	16-1/8	25-5/8	30	14-7/8	8-1/8	24	16'-8"	12'-7-1/8"	5	2
		12'	GLCSLX-FS-2000-15 (S or AL)-34-12	Steel	30'	13	16-1/8	25-5/8	30	14-7/8	8-1/8	24	16'-8"	14'-7-1/8"	5	2
		14'	GLCSLX-FS-2000-15 (S or AL)-34-14	Steel	30'	13	16-1/8	25-5/8	30	14-7/8	8-1/8	24	16'-8"	16'-8-1/8"	5	2
10'		AL-FS-2000-15-34-10	Alum	20'	19	17	25-1/4	-	13-3/8	8	24-3/8	16'-8"	16'-6-3/4"	5	3	
43'	10'	GLCS-FS-2000-15 (S or AL)-43-10	Steel	20'	19	16-1/8	19-5/8	24	14-7/8	8-1/8	24	16'-8"	12'-1-1/8"	5	3	
	10'	AL-FS-2000-15-43-10	Alum	20'	26	17	25-1/4	-	13-3/8	8	24-3/8	16'-8"	12'-6-3/4"	5	3	
	12'	GLCS-FS-2000-15 (S or AL)-43-12	Steel	20'	19	16-1/8	19-5/8	24	14-7/8	8-1/8	24	16'-8"	14'-1-1/8"	5	3	
	12'	AL-FS-2000-15-43-12	Alum	20'	26	17	25-1/4	-	13-3/8	8	24-3/8	16'-8"	14'-6-3/4"	5	3	
53'	10'	GLCS-FS-2000-15 (S or AL)-53-10	Steel	20'	19	16-1/8	19-5/8	24	14-7/8	8-1/8	24	16'-8"	12'-1-1/8"	5	4	
	10'	AL-FS-2000-15-53-10	Alum	20'	30	17	25-1/4	-	13-3/8	8	24-3/8	16'-8"	12'-6-3/4"	5	4	
	12'	GLCSL-FS-2000-15 (S or AL)-53-10	Steel	25'	19	16-1/8	23	27-3/8	14-7/8	8-1/8	24	16'-8"	12'-4-1/2"	5	3	
	12'	GLCS-FS-2000-15 (S or AL)-53-12	Steel	20'	19	16-1/8	19-5/8	24	14-7/8	8-1/8	24	16'-8"	14'-1-1/8"	5	4	
63'	10'	GLCS-FS-2000-15 (S or AL)-63-10	Steel	20'	26	16-1/8	19-5/8	24	14-7/8	8-1/8	24	16'-8"	12'-1-1/8"	5	4	
	10'	AL-FS-2000-15-63-10	Alum	20'	36	17	25-1/4	-	13-3/8	8	24-3/8	16'-8"	12'-6-3/4"	5	4	
	12'	GLCS-FS-2000-15 (S or AL)-63-12	Steel	20'	26	16-1/8	19-5/8	24	14-7/8	8-1/8	24	16'-8"	14'-1-1/8"	5	4	
	12'	AL-FS-2000-15-63-12	Alum	20'	36	17	25-1/4	-	13-3/8	8	24-3/8	16'-8"	14'-6-3/4"	5	4	
64'	10'	GLCSLX-FS-2000-15 (S or AL)-64-10	Steel	30'	36	16-1/8	25-5/8	30	14-7/8	8-1/8	24-3/8	16'-8"	12'-7-1/8"	5	3	
	12'	GLCSLX-FS-2000-15 (S or AL)-64-12	Steel	30'	36	16-1/8	25-5/8	30	14-7/8	8-1/8	24-3/8	16'-8"	14'-7-1/8"	5	3	
	14'	GLCSLX-FS-2000-15 (S or AL)-64-14	Steel	30'	36	16-1/8	25-5/8	30	14-7/8	8-1/8	24-3/8	16'-8"	16'-8-1/8"	5	3	
	10'	AL-FS-2000-15-64-10	Alum	20'	46	17	25-1/4	-	13-3/8	8	24-3/8	16'-8"	16'-6-3/4"	5	5	
78'	10'	GLCSL-FS-2000-15 (S or AL)-78-10	Steel	25'	46	16-1/8	23	27-3/8	14-7/8	8-1/8	24-3/8	16'-8"	12'-4-1/2"	5	4	
	12'	GLCSL-FS-2000-15 (S or AL)-78-12	Steel	25'	46	16-1/8	23	27-3/8	14-7/8	8-1/8	24-3/8	16'-8"	14'-4-1/2"	5	4	
	14'	GLCSL-FS-2000-15 (S or AL)-78-14	Steel	25'	46	16-1/8	23	27-3/8	14-7/8	8-1/8	24-3/8	16'-8"	16'-4-1/2"	5	4	
	10'	AL-FS-2000-15-78-10	Alum	20'	46	17	25-1/4	-	13-3/8	8	24-3/8	16'-8"	12'-6-3/4"	5	5	
83'	10'	GLCS-FS-2000-15 (S or AL)-83-10	Steel	20'	46	16-1/8	19-5/8	24	14-7/8	8-1/8	24-3/8	16'-8"	12'-1-1/8"	5	5	
	10'	AL-FS-2000-15-83-10	Alum	20'	46	17	25-1/4	-	13-3/8	8	24-3/8	16'-8"	12'-6-3/4"	5	5	
	12'	GLCS-FS-2000-15 (S or AL)-83-12	Steel	20'	46	16-1/8	19-5/8	24	14-7/8	8-1/8	24-3/8	16'-8"	14'-1-1/8"	5	5	
	12'	AL-FS-2000-15-83-12	Alum	20'	46	17	25-1/4	-	13-3/8	8	24-3/8	16'-8"	14'-6-3/4"	5	5	
94'	10'	GLCSLX-FS-2000-15 (S or AL)-94-10	Steel	30'	54	16-1/8	25-5/8	30	14-7/8	8-1/8	24-3/8	16'-8"	12'-7-1/8"	5	4	
	12'	GLCSLX-FS-2000-15 (S or AL)-94-12	Steel	30'	54	16-1/8	25-5/8	30	14-7/8	8-1/8	24-3/8	16'-8"	14'-7-1/8"	5	4	
	14'	GLCSLX-FS-2000-15 (S or AL)-94-14	Steel	30'	54	16-1/8	25-5/8	30	14-7/8	8-1/8	24-3/8	16'-8"	16'-8-1/8"	5	4	
	10'	AL-FS-2000-15-94-10	Alum	20'	54	17	25-1/4	-	13-3/8	8	24-3/8	16'-8"	16'-6-3/4"	5	6	
103'	10'	GLCSL-FS-2000-15 (S or AL)-103-10	Steel	25'	54	16-1/8	23	27-3/8	14-7/8	8-1/8	24-3/8	16'-8"	12'-4-1/2"	5	5	
	10'	AL-FS-2000-15-103-10	Alum	20'	54	17	25-1/4	-	13-3/8	8	24-3/8	16'-8"	12'-6-3/4"	5	6	
	12'	GLCS-FS-2000-15 (S or AL)-103-12	Steel	20'	54	16-1/8	19-5/8	24	14-7/8	8-1/8	24-3/8	16'-8"	14'-1-1/8"	5	6	
	12'	AL-FS-2000-15-103-12	Alum	20'	54	17	25-1/4	-	13-3/8	8	24-3/8	16'-8"	14'-6-3/4"	5	6	
124'	10'	GLCSL-FS-2000-15 (S or AL)-103-12	Steel	25'	54	16-1/8	23	27-3/8	14-7/8	8-1/8	24-3/8	16'-8"	12'-4-1/2"	5	5	
	14'	GLCS-FS-2000-15 (S or AL)-103-14	Steel	20'	54	16-1/8	19-5/8	24	14-7/8	8-1/8	24-3/8	16'-8"	16'-1-1/8"	5	6	
	14'	AL-FS-2000-15-103-14	Alum	20'	54	17	25-1/4	-	13-3/8	8	24-3/8	16'-8"	16'-6-3/4"	5	6	
	14'	GLCSL-FS-2000-15 (S or AL)-103-14	Steel	25'	54	16-1/8	23	27-3/8	14-7/8	8-1/8	24-3/8	16'-8"	16'-4-1/2"	5	5	
124'	10'	GLCSLX-FS-2000-15 (S or AL)-124-10	Steel	30'	54	16-1/8	25-5/8	30	14-7/8	8-1/8	24-3/8	16'-8"	12'-7-1/8"	5	5	
	12'	GLCSLX-FS-2000-15 (S or AL)-124-12	Steel	30'	54	16-1/8	25-5/8	30	14-7/8	8-1/8	24-3/8	16'-8"	14'-7-1/8"	5	5	
	14'	GLCSLX-FS-2000-15 (S or AL)-124-14	Steel	30'	54	16-1/8	25-5/8	30	14-7/8	8-1/8	24-3/8	16'-8"	16'-8-1/8"	5	5	

*This column provides the total number of support assemblies based on the "L1" dimensions shown. Support assemblies are designed to AISC specifications and do not require bracing. If no movement of the support assembly is preferred, then bracing to the building steel is recommended (not included).
To Determine Hook Coverage: [Bridge Travel on Runway - Runway Length - (2xL8)] by [Hoist Trolley Travel on Bridge - Bridge Length - L3 - L6] (L6 allows for festoon stack-up).
Gorbel Free Standing Work Station Bridge Crane kits include: bridge, runways, the appropriate number of support assemblies, hoist trolley, end trucks, end stops, flat wire festooning, festoon gliders (festoon trolleys on steel runways greater than 63' and all aluminum systems), festoon stack-up section, splice joints and hanger brackets. Hoist and anchor bolts provided by others.
Dimensions are for reference only and are subject to change without notice.

FREE STANDING WORK STATION BRIDGE CRANES

BRIDGE LENGTH (L)	RUNWAY LENGTH	TS	MODEL NUMBER	TRACK MAT.	RUNWAY			BRIDGE				SUPPORT				
					MAX. L1	L7 in	L8 in	H3 in	H3A in	H4 in	L3 in	L6 in	OA	OAH	D in	g
20'	23'	10'	GLCS-FS-2000-20 (S or AL)-23-10	Steel	20'	9	16-1/8	19-5/8	24	14-7/8	8-1/8	24	21'-8"	12'-1-1/8"	5	2
		10'	AL-FS-2000-20-23-10	Alum	20'	13	17	25-1/4	-	15-1/2	8	27-3/4	21'-8"	12'-6-3/4"	5	2
		12'	GLCS-FS-2000-20 (S or AL)-23-12	Steel	20'	9	16-1/8	19-5/8	24	14-7/8	8-1/8	24	21'-8"	14'-1-1/8"	5	2
		12'	AL-FS-2000-20-23-12	Alum	20'	13	17	25-1/4	-	15-1/2	8	27-3/4	21'-8"	14'-6-3/4"	5	2
	28'	10'	GLCSL-FS-2000-20 (S or AL)-28-10	Steel	25'	13	16-1/8	23	27-3/8	14-7/8	8-1/8	24	21'-8"	12'-4-1/2"	5	2
		12'	GLCSL-FS-2000-20 (S or AL)-28-12	Steel	25'	13	16-1/8	23	27-3/8	14-7/8	8-1/8	24	21'-8"	14'-4-1/2"	5	2
		14'	GLCSL-FS-2000-20 (S or AL)-28-14	Steel	25'	13	16-1/8	23	27-3/8	14-7/8	8-1/8	24	21'-8"	16'-5-1/2"	5	2
		10'	AL-FS-2000-20-33-10	Alum	20'	19	17	25-1/4	-	15-1/2	8	27-3/4	21'-8"	12'-1-1/8"	5	3
	33'	10'	GLCSL-FS-2000-20 (S or AL)-33-10	Steel	20'	13	16-1/8	19-5/8	24	14-7/8	8-1/8	24	21'-8"	12'-1-1/8"	5	3
		12'	GLCSL-FS-2000-20 (S or AL)-33-12	Steel	20'	13	16-1/8	19-5/8	24	14-7/8	8-1/8	24	21'-8"	14'-1-1/8"	5	3
		12'	AL-FS-2000-20-33-12	Alum	20'	19	17	25-1/4	-	15-1/2	8	27-3/4	21'-8"	14'-6-3/4"	5	3
		14'	GLCSL-FS-2000-20 (S or AL)-33-14	Steel	20'	13	16-1/8	19-5/8	24	14-7/8	8-1/8	24	21'-8"	16'-2-1/8"	5	3
	34'	10'	AL-FS-2000-20-33-14	Alum	20'	19	17	25-1/4	-	15-1/2	8	27-3/4	21'-8"	16'-7-3/4"	5	3
		10'	GLCSLX-FS-2000-20 (S or AL)-34-10	Steel	30'	13	16-1/8	25-5/8	30	14-7/8	8-1/8	24	21'-8"	12'-7-1/8"	5	2
		12'	GLCSLX-FS-2000-20 (S or AL)-34-12	Steel	30'	13	16-1/8	25-5/8	30	14-7/8	8-1/8	24	21'-8"	14'-7-1/8"	5	2
		14'	GLCSLX-FS-2000-20 (S or AL)-34-14	Steel	30'	13	16-1/8	25-5/8	30	14-7/8	8-1/8	24	21'-8"	16'-8-1/8"	5	2
	43'	10'	GLCS-FS-2000-20 (S or AL)-43-10	Steel	20'	19	16-1/8	19-5/8	24	14-7/8	8-1/8	24	21'-8"	12'-1-1/8"	5	3
		10'	AL-FS-2000-20-43-10	Alum	20'	26	17	25-1/4	-	15-1/2	8	27-3/4	21'-8"	12'-6-3/4"	5	3
		12'	GLCS-FS-2000-20 (S or AL)-43-12	Steel	20'	19	16-1/8	19-5/8	24	14-7/8	8-1/8	24	21'-8"	14'-1-1/8"	5	3
		12'	AL-FS-2000-20-43-12	Alum	20'	26	17	25-1/4	-	15-1/2	8	27-3/4	21'-8"	14'-6-3/4"	5	3
	53'	10'	GLCS-FS-2000-20 (S or AL)-43-14	Steel	20'	19	16-1/8	19-5/8	24	14-7/8	8-1/8	24	21'-8"	16'-2-1/8"	5	3
		10'	AL-FS-2000-20-43-14	Alum	20'	26	17	25-1/4	-	15-1/2	8	27-3/4	21'-8"	16'-7-3/4"	5	3
		10'	GLCS-FS-2000-20 (S or AL)-53-10	Steel	20'	19	16-1/8	19-5/8	24	14-7/8	8-1/8	24	21'-8"	12'-1-1/8"	5	4
		10'	AL-FS-2000-20-53-10	Alum	20'	30	17	25-1/4	-	15-1/2	8	27-3/4	21'-8"	12'-6-3/4"	5	4
	53'	10'	GLCSL-FS-2000-20 (S or AL)-53-10	Steel	25'	19	16-1/8	23	27-3/8	14-7/8	8-1/8	24	21'-8"	12'-4-1/2"	5	3
		12'	GLCSL-FS-2000-20 (S or AL)-53-12	Steel	20'	19	16-1/8	19-5/8	24	14-7/8	8-1/8	24	21'-8"	14'-1-1/8"	5	4
		12'	AL-FS-2000-20-53-12	Alum	20'	30	17	25-1/4	-	15-1/2	8	27-3/4	21'-8"	14'-6-3/4"	5	4
		12'	GLCSL-FS-2000-20 (S or AL)-53-12	Steel	25'	19	16-1/8	23	27-3/8	14-7/8	8-1/8	24	21'-8"	14'-4-1/2"	5	3
	63'	10'	GLCS-FS-2000-20 (S or AL)-53-14	Steel	20'	19	16-1/8	19-5/8	24	14-7/8	8-1/8	24	21'-8"	16'-2-1/8"	5	4
		10'	AL-FS-2000-20-53-14	Alum	20'	30	17	25-1/4	-	15-1/2	8	27-3/4	21'-8"	16'-7-3/4"	5	4
		14'	GLCSL-FS-2000-20 (S or AL)-53-14	Steel	25'	19	16-1/8	23	27-3/8	14-7/8	8-1/8	24	21'-8"	16'-5-1/2"	5	3
		10'	GLCS-FS-2000-20 (S or AL)-63-10	Steel	20'	26	16-1/8	19-5/8	24	14-7/8	8-1/8	24	21'-8"	12'-1-1/8"	5	4
	63'	10'	AL-FS-2000-20-63-10	Alum	20'	36	17	25-1/4	-	15-1/2	8	27-3/4	21'-8"	12'-6-3/4"	5	4
		12'	GLCS-FS-2000-20 (S or AL)-63-12	Steel	20'	26	16-1/8	19-5/8	24	14-7/8	8-1/8	24	21'-8"	14'-1-1/8"	5	4
		12'	AL-FS-2000-20-63-12	Alum	20'	36	17	25-1/4	-	15-1/2	8	27-3/4	21'-8"	14'-6-3/4"	5	4
		14'	GLCS-FS-2000-20 (S or AL)-63-14	Steel	20'	26	16-1/8	19-5/8	24	14-7/8	8-1/8	24	21'-8"	16'-2-1/8"	5	4
	64'	10'	AL-FS-2000-20-63-14	Alum	20'	36	17	25-1/4	-	15-1/2	8	27-3/4	21'-8"	16'-7-3/4"	5	4
		10'	GLCSLX-FS-2000-20 (S or AL)-64-10	Steel	30'	36	16-1/8	25-5/8	30	14-7/8	8-1/8	27-3/4	21'-8"	12'-7-1/8"	5	3
		12'	GLCSLX-FS-2000-20 (S or AL)-64-12	Steel	30'	36	16-1/8	25-5/8	30	14-7/8	8-1/8	27-3/4	21'-8"	14'-7-1/8"	5	3
		14'	GLCSLX-FS-2000-20 (S or AL)-64-14	Steel	30'	36	16-1/8	25-5/8	30	14-7/8	8-1/8	27-3/4	21'-8"	16'-8-1/8"	5	3
	78'	10'	GLCSL-FS-2000-20 (S or AL)-78-10	Steel	25'	46	16-1/8	23	27-3/8	14-7/8	8-1/8	27-3/4	21'-8"	12'-4-1/2"	5	4
		12'	GLCSL-FS-2000-20 (S or AL)-78-12	Steel	25'	46	16-1/8	23	27-3/8	14-7/8	8-1/8	27-3/4	21'-8"	14'-4-1/2"	5	4
		14'	GLCSL-FS-2000-20 (S or AL)-78-14	Steel	25'	46	16-1/8	23	27-3/8	14-7/8	8-1/8	27-3/4	21'-8"	16'-5-1/2"	5	4
		10'	GLCS-FS-2000-20 (S or AL)-83-10	Steel	20'	46	16-1/8	19-5/8	24	14-7/8	8-1/8	27-3/4	21'-8"	12'-1-1/8"	5	5
	83'	10'	AL-FS-2000-20-83-10	Alum	20'	46	17	25-1/4	-	15-1/2	8	27-3/4	21'-8"	12'-6-3/4"	5	5
		12'	GLCS-FS-2000-20 (S or AL)-83-12	Steel	20'	46	16-1/8	19-5/8	24	14-7/8	8-1/8	27-3/4	21'-8"	14'-1-1/8"	5	5
		12'	AL-FS-2000-20-83-12	Alum	20'	46	17	25-1/4	-	15-1/2	8	27-3/4	21'-8"	14'-6-3/4"	5	5
		14'	GLCS-FS-2000-20 (S or AL)-83-14	Steel	20'	46	16-1/8	19-5/8	24	14-7/8	8-1/8	27-3/4	21'-8"	16'-2-1/8"	5	5
	83'	10'	AL-FS-2000-20-83-14	Alum	20'	46	17	25-1/4	-	15-1/2	8	27-3/4	21'-8"	16'-7-3/4"	5	5
		10'	GLCSLX-FS-2000-20 (S or AL)-94-10	Steel	30'	54	16-1/8	25-5/8	30	14-7/8	8-1/8	27-3/4	21'-8"	12'-7-1/8"	5	4
		12'	GLCSLX-FS-2000-20 (S or AL)-94-12	Steel	30'	54	16-1/8	25-5/8	30	14-7/8	8-1/8	27-3/4	21'-8"	14'-7-1/8"	5	4
		14'	GLCSLX-FS-2000-20 (S or AL)-94-14	Steel	30'	54	16-1/8	25-5/8	30	14-7/8	8-1/8	27-3/4	21'-8"	16'-8-1/8"	5	4
	103'	10'	GLCS-FS-2000-20 (S or AL)-103-10	Steel	20'	54	16-1/8	19-5/8	24	14-7/8	8-1/8	27-3/4	21'-8"	12'-1-1/8"	5	6
		10'	AL-FS-2000-20-103-10	Alum	20'	54	17	25-1/4	-	15-1/2	8	27-3/4	21'-8"	12'-6-3/4"	5	6
		12'	GLCSL-FS-2000-20 (S or AL)-103-12	Steel	25'	54	16-1/8	23	27-3/8	14-7/8	8-1/8	27-3/4	21'-8"	12'-4-1/2"	5	5
		12'	GLCS-FS-2000-20 (S or AL)-103-12	Steel	20'	54	16-1/8	19-5/8	24	14-7/8	8-1/8	27-3/4	21'-8"	14'-1-1/8"	5	6
	103'	12'	AL-FS-2000-20-103-12	Alum	20'	54	17	25-1/4	-	15-1/2	8	27-3/4	21'-8"	14'-6-3/4"	5	6
		14'	GLCSL-FS-2000-20 (S or AL)-103-14	Steel	25'	54	16-1/8	23	27-3/8	14-7/8	8-1/8	27-3/4	21'-8"	14'-4-1/2"	5	5
		14'	GLCS-FS-2000-20 (S or AL)-103-14	Steel	20'	54	16-1/8	19-5/8	24	14-7/8	8-1/8	27-3/4	21'-8"	16'-2-1/8"	5	6
		14'	AL-FS-2000-20-103-14	Alum	20'	54	17	25-1/4	-	15-1/2	8	27-3/4	21'-8"	16'-7-3/4"	5	6
	124'	10'	GLCSL-FS-2000-20 (S or AL)-103-14	Steel	25'	54	16-1/8	23	27-3/8	14-7/8	8-1/8	27-3/4	21'-8"	16'-5-1/2"	5	5
		10'	GLCSLX-FS-2000-20 (S or AL)-124-10	Steel	30'	54	16-1/8	25-5/8	30	14-7/8	8-1/8	27-3/4	21'-8"	12'-7-1/8"	5	5
		12'	GLCSLX-FS-2000-20 (S or AL)-124-12	Steel	30'	54	16-1/8	25-5/8	30	14-7/8	8-1/8	27-3/4	21'-8"	14'-7-1/8"	5	5
		14'	GLCSLX-FS-2000-20 (S or AL)-124-14	Steel	30'	54	16-1/8	25-5/8	30	14-7/8	8-1/8	27-3/4	21'-8"	16'-8-1/8"	5	5

*This column provides the total number of support assemblies based on the "L1" dimensions shown. Support assemblies are designed to AISC specifications and do not require bracing. If no movement of the support assembly is preferred, then bracing to the building steel is recommended (not included).
 To Determine Hook Coverage: [Bridge Travel on Runway = Runway Length - (2xL8)] by [Hoist Trolley Travel on Bridge = Bridge Length - L3 - L6] (L6 allows for festoon stack-up).
 Gorbel Free Standing Work Station Bridge Crane kits include: bridge, runways, the appropriate number of support assemblies, hoist trolley, and trucks, end stops, flat wire festooning, festoon gliders (festoon trolleys on steel runway lengths greater than 63' and all aluminum systems), festoon stack-up section, splice joints and hanger brackets. Hoist and anchor bolts provided by others.
 Dimensions are for reference only and are subject to change without notice.

FREE STANDING WORK STATION BRIDGE CRANES

BRIDGE LENGTH (L)	RUNWAY LENGTH	TS	MODEL NUMBER	TRACK MAT.	RUNWAY			BRIDGE						SUPPORT STRUCTURE			
					MAX. L1	L7 in	L8 in	H3 in	H3A in	H4 in	L3 in	L6 in	OAW	OAH	D in	J-46	
23'	23'	10'	GLCS-FS-2000-23 (S or AL)-23-10	Steel	20'	9	16-1/8	19-5/8	24	14-7/8	8-1/8	24	24-8"	12'-1-1/8"	5	2	
		10'	AL-FS-2000-23-23-10	Alum	20'	13	17	25-1/4	-	15-1/2	8	31-1/8	24-8"	12'-6-3/4"	5	2	
		12'	GLCS-FS-2000-23 (S or AL)-23-12	Steel	20'	9	16-1/8	19-5/8	24	14-7/8	8-1/8	24	24-8"	14'-2-1/8"	5	2	
		12'	AL-FS-2000-23-23-12	Alum	20'	13	17	25-1/4	-	15-1/2	8	31-1/8	24-8"	14'-7-3/4"	5	2	
	28'	10'	GLCSL-FS-2000-23 (S or AL)-28-10	Steel	25'	13	16-1/8	23	27-3/8	14-7/8	8-1/8	24	24-8"	12'-4-1/2"	5	2	
		10'	AL-FS-2000-23-28-10	Alum	25'	13	16-1/8	23	27-3/8	14-7/8	8-1/8	24	24-8"	14'-5-1/2"	5	2	
		12'	GLCSL-FS-2000-23 (S or AL)-28-12	Steel	25'	13	16-1/8	23	27-3/8	14-7/8	8-1/8	24	24-8"	16'-6-1/2"	5	2	
		12'	AL-FS-2000-23-28-12	Alum	25'	13	16-1/8	23	27-3/8	14-7/8	8-1/8	24	24-8"	16'-6-1/2"	5	2	
	33'	10'	GLCS-FS-2000-23 (S or AL)-33-10	Steel	20'	13	16-1/8	19-5/8	24	14-7/8	8-1/8	24	24-8"	12'-1-1/8"	5	3	
		10'	AL-FS-2000-23-33-10	Alum	20'	19	17	25-1/4	-	15-1/2	8	31-1/8	24-8"	12'-6-3/4"	5	3	
		12'	GLCS-FS-2000-23 (S or AL)-33-12	Steel	20'	13	16-1/8	19-5/8	24	14-7/8	8-1/8	24	24-8"	14'-2-1/8"	5	3	
		12'	AL-FS-2000-23-33-12	Alum	20'	19	17	25-1/4	-	15-1/2	8	31-1/8	24-8"	14'-7-3/4"	5	3	
34'	10'	GLCSLX-FS-2000-23 (S or AL)-34-10	Steel	30'	13	16-1/8	25-5/8	30	14-7/8	8-1/8	24	24-8"	12'-7-1/8"	5	2		
	10'	AL-FS-2000-23-34-10	Alum	30'	13	16-1/8	25-5/8	30	14-7/8	8-1/8	24	24-8"	14'-8-1/8"	5	2		
	12'	GLCSLX-FS-2000-23 (S or AL)-34-12	Steel	30'	13	16-1/8	25-5/8	30	14-7/8	8-1/8	24	24-8"	16'-9-1/8"	5	2		
	12'	AL-FS-2000-23-34-12	Alum	30'	13	16-1/8	25-5/8	30	14-7/8	8-1/8	24	24-8"	16'-9-1/8"	5	2		
43'	10'	GLCS-FS-2000-23 (S or AL)-43-10	Steel	20'	19	16-1/8	19-5/8	24	14-7/8	8-1/8	24	24-8"	12'-1-1/8"	5	3		
	10'	AL-FS-2000-23-43-10	Alum	20'	26	17	25-1/4	-	15-1/2	8	31-1/8	24-8"	12'-6-3/4"	5	3		
	12'	GLCS-FS-2000-23 (S or AL)-43-12	Steel	20'	19	16-1/8	19-5/8	24	14-7/8	8-1/8	24	24-8"	14'-2-1/8"	5	3		
	12'	AL-FS-2000-23-43-12	Alum	20'	26	17	25-1/4	-	15-1/2	8	31-1/8	24-8"	14'-7-3/4"	5	3		
53'	10'	GLCS-FS-2000-23 (S or AL)-53-10	Steel	20'	19	16-1/8	19-5/8	24	14-7/8	8-1/8	24	24-8"	12'-1-1/8"	5	4		
	10'	AL-FS-2000-23-53-10	Alum	20'	30	17	25-1/4	-	15-1/2	8	31-1/8	24-8"	12'-6-3/4"	5	4		
	12'	GLCSL-FS-2000-23 (S or AL)-53-12	Steel	25'	19	16-1/8	23	27-3/8	14-7/8	8-1/8	24	24-8"	14'-2-1/8"	5	4		
	12'	AL-FS-2000-23-53-12	Alum	20'	30	17	25-1/4	-	15-1/2	8	31-1/8	24-8"	14'-7-3/4"	5	4		
63'	10'	GLCSL-FS-2000-23 (S or AL)-63-10	Steel	25'	19	16-1/8	19-5/8	24	14-7/8	8-1/8	24	24-8"	12'-1-1/8"	5	4		
	10'	AL-FS-2000-23-63-10	Alum	25'	26	17	25-1/4	-	15-1/2	8	31-1/8	24-8"	12'-6-3/4"	5	4		
	12'	GLCS-FS-2000-23 (S or AL)-63-12	Steel	20'	19	16-1/8	19-5/8	24	14-7/8	8-1/8	24	24-8"	14'-2-1/8"	5	4		
	12'	AL-FS-2000-23-63-12	Alum	20'	26	17	25-1/4	-	15-1/2	8	31-1/8	24-8"	14'-7-3/4"	5	4		
64'	10'	GLCSLX-FS-2000-23 (S or AL)-64-10	Steel	30'	36	16-1/8	25-5/8	30	14-7/8	8-1/8	31-1/8	24-8"	12'-7-1/8"	5	3		
	10'	AL-FS-2000-23-64-10	Alum	30'	36	16-1/8	25-5/8	30	14-7/8	8-1/8	31-1/8	24-8"	14'-8-1/8"	5	3		
	12'	GLCSLX-FS-2000-23 (S or AL)-64-12	Steel	30'	36	16-1/8	25-5/8	30	14-7/8	8-1/8	31-1/8	24-8"	16'-9-1/8"	5	3		
	12'	AL-FS-2000-23-64-12	Alum	30'	36	16-1/8	25-5/8	30	14-7/8	8-1/8	31-1/8	24-8"	16'-9-1/8"	5	3		
78'	10'	GLCSL-FS-2000-23 (S or AL)-78-10	Steel	25'	46	16-1/8	23	27-3/8	14-7/8	8-1/8	31-1/8	24-8"	12'-4-1/2"	5	4		
	10'	AL-FS-2000-23-78-10	Alum	25'	46	16-1/8	23	27-3/8	14-7/8	8-1/8	31-1/8	24-8"	14'-5-1/2"	5	4		
	12'	GLCSL-FS-2000-23 (S or AL)-78-12	Steel	25'	46	16-1/8	23	27-3/8	14-7/8	8-1/8	31-1/8	24-8"	16'-6-1/2"	5	4		
	12'	AL-FS-2000-23-78-12	Alum	25'	46	16-1/8	23	27-3/8	14-7/8	8-1/8	31-1/8	24-8"	16'-6-1/2"	5	4		
83'	10'	GLCS-FS-2000-23 (S or AL)-83-10	Steel	20'	46	16-1/8	19-5/8	24	14-7/8	8-1/8	31-1/8	24-8"	12'-1-1/8"	5	5		
	10'	AL-FS-2000-23-83-10	Alum	20'	46	17	25-1/4	-	15-1/2	8	31-1/8	24-8"	12'-6-3/4"	5	5		
	12'	GLCS-FS-2000-23 (S or AL)-83-12	Steel	20'	46	16-1/8	19-5/8	24	14-7/8	8-1/8	31-1/8	24-8"	14'-2-1/8"	5	5		
	12'	AL-FS-2000-23-83-12	Alum	20'	46	17	25-1/4	-	15-1/2	8	31-1/8	24-8"	14'-7-3/4"	5	5		
94'	10'	GLCSLX-FS-2000-23 (S or AL)-94-10	Steel	30'	54	16-1/8	25-5/8	30	14-7/8	8-1/8	31-1/8	24-8"	12'-7-1/8"	5	4		
	10'	AL-FS-2000-23-94-10	Alum	30'	54	16-1/8	25-5/8	30	14-7/8	8-1/8	31-1/8	24-8"	14'-8-1/8"	5	4		
	12'	GLCSLX-FS-2000-23 (S or AL)-94-12	Steel	30'	54	16-1/8	25-5/8	30	14-7/8	8-1/8	31-1/8	24-8"	16'-9-1/8"	5	4		
	12'	AL-FS-2000-23-94-12	Alum	30'	54	16-1/8	25-5/8	30	14-7/8	8-1/8	31-1/8	24-8"	16'-9-1/8"	5	4		
103'	10'	GLCS-FS-2000-23 (S or AL)-103-10	Steel	20'	54	16-1/8	19-5/8	24	14-7/8	8-1/8	31-1/8	24-8"	12'-1-1/8"	5	6		
	10'	AL-FS-2000-23-103-10	Alum	20'	54	17	25-1/4	-	15-1/2	8	31-1/8	24-8"	12'-6-3/4"	5	6		
	12'	GLCSL-FS-2000-23 (S or AL)-103-12	Steel	25'	54	16-1/8	23	27-3/8	14-7/8	8-1/8	31-1/8	24-8"	14'-2-1/8"	5	6		
	12'	AL-FS-2000-23-103-12	Alum	20'	54	16-1/8	19-5/8	24	14-7/8	8-1/8	31-1/8	24-8"	14'-7-3/4"	5	6		
124'	10'	GLCSL-FS-2000-23 (S or AL)-124-10	Steel	25'	54	16-1/8	19-5/8	24	14-7/8	8-1/8	31-1/8	24-8"	12'-1-1/8"	5	5		
	10'	AL-FS-2000-23-124-10	Alum	25'	54	16-1/8	19-5/8	24	14-7/8	8-1/8	31-1/8	24-8"	12'-6-3/4"	5	5		
	12'	GLCSLX-FS-2000-23 (S or AL)-124-12	Steel	30'	54	16-1/8	25-5/8	30	14-7/8	8-1/8	31-1/8	24-8"	14'-8-1/8"	5	5		
	12'	AL-FS-2000-23-124-12	Alum	30'	54	16-1/8	25-5/8	30	14-7/8	8-1/8	31-1/8	24-8"	16'-9-1/8"	5	5		
23'	23'	10'	GLCS-FS-2000-28 (S or AL)-23-10	Steel	20'	9	25-7/8	23	26	18-1/4	8-1/8	34-1/2	29-8"	12'-5-1/2"	5	2	
		10'	AL-FS-2000-28-23-10	Alum	20'	13	21	27-1/2	-	17	8	37-7/8	29-8"	12'-10"	5	2	
		12'	GLCS-FS-2000-28 (S or AL)-23-12	Steel	20'	9	25-7/8	23	26	18-1/4	8-1/8	34-1/2	29-8"	14'-5-1/2"	5	2	
		12'	AL-FS-2000-28-23-12	Alum	20'	13	21	27-1/2	-	17	8	37-7/8	29-8"	14'-10"	5	2	
	28'	10'	GLCSL-FS-2000-28 (S or AL)-28-10	Steel	25'	9	25-7/8	26-3/8	29-3/8	18-1/4	8-1/8	34-1/2	29-8"	12'-8-7/8"	5	2	
		10'	AL-FS-2000-28-28-10	Alum	25'	9	25-7/8	26-3/8	29-3/8	18-1/4	8-1/8	34-1/2	29-8"	14'-8-7/8"	5	2	
		12'	GLCSL-FS-2000-28 (S or AL)-28-12	Steel	25'	9	25-7/8	26-3/8	29-3/8	18-1/4	8-1/8	34-1/2	29-8"	16'-9-7/8"	5	2	
		12'	AL-FS-2000-28-28-12	Alum	20'	13	21	27-1/2	-	17	8	37-7/8	29-8"	16'-11"	5	2	
	33'	10'	GLCS-FS-2000-28 (S or AL)-33-10	Steel	20'	9	25-7/8	23	26	18-1/4	8-1/8	34-1/2	29-8"	12'-5-1/2"	5	3	
		10'	AL-FS-2000-28-33-10	Alum	20'	19	21	27-1/2	-	17	8	37-7/8	29-8"	12'-10"	5	3	
		12'	GLCS-FS-2000-28 (S or AL)-33-12	Steel	20'	9	25-7/8	23	26	18-1/4	8-1/8	34-1/2	29-8"	14'-5-1/2"	5	3	
		12'	AL-FS-2000-28-33-12	Alum	20'	19	21	27-1/2	-	17	8	37-7/8	29-8"	14'-10"	5	3	
34'	10'	GLCSLX-FS-2000-28 (S or AL)-34-10	Steel	30'	9	25-7/8	29	32	18-1/4	8-1/8	34-1/2	29-8"	12'-11-1/2"	5	2		
	10'	AL-FS-2000-28-34-10	Alum	30'	9	25-7/8	29	32	18-1/4	8-1/8	34-1/2	29-8"	14'-11-1/2"	5	2		
	12'	GLCSLX-FS-2000-28 (S or AL)-34-12	Steel	30'	9	25-7/8	29	32	18-1/4	8-1/8	34-1/2	29-8"	17'-0-1/2"	5	2		
	12'	AL-FS-2000-28-34-12	Alum	20'	13	21	27-1/2	-	17	8	37-7/8	29-8"	17'-0-1/2"	5	2		
43'	10'	GLCS-FS-2000-28 (S or AL)-43-10	Steel	20'	13	25-7/8	23	26	18-1/4	8-1/8	34-1/2	29-8"	12'-5-1/2"	5	3		
	10'	AL-FS-2000-28-43-10	Alum	20'	26	21	27-1/2	-	17	8	37-7/8	29-8"	12'-10"	5	3		
	12'	GLCS-FS-2000-28 (S or AL)-43-12	Steel	20'	13	25-7/8	23	26	18-1/4	8-1/8	34-1/2	29-8"	14'-5-1/2"	5	3		
	12'	AL-FS-2000-28-43-12	Alum	20'	26	21	27-1/2	-									

FREE STANDING WORK STATION BRIDGE CRANES

BRIDGE LENGTH (L)	RUNWAY LENGTH	TS	MODEL NUMBER	TRACK MAT.	RUNWAY			BRIDGE				SUPPORT STRUCTURE				
					MAX. L1	L7 in	L8 in	H3 in	H3A in	H4 in	L3 in	L6 in	OAW	OAH	D in	Spt
28'	64'	10'	GLCSLX-FS-2000-28 (S or AL)-64-10	Steel	30'	36	25-7/8	29	32	18-1/4	8-1/8	37-7/8	29'-8"	12'-11-1/2"	5	3
		12'	GLCSLX-FS-2000-28 (S or AL)-64-12	Steel	30'	36	25-7/8	29	32	18-1/4	8-1/8	37-7/8	29'-8"	14'-11-1/2"	5	3
		14'	GLCSLX-FS-2000-28 (S or AL)-64-14	Steel	30'	36	25-7/8	29	32	18-1/4	8-1/8	37-7/8	29'-8"	17'-0-1/2"	5	3
	78'	10'	GLCSL-FS-2000-28 (S or AL)-78-10	Steel	25'	46	25-7/8	26-3/8	29-3/8	18-1/4	8-1/8	37-7/8	29'-8"	12'-8-7/8"	5	4
		12'	GLCSL-FS-2000-28 (S or AL)-78-12	Steel	25'	46	25-7/8	26-3/8	29-3/8	18-1/4	8-1/8	37-7/8	29'-8"	14'-8-7/8"	5	4
		14'	GLCSL-FS-2000-28 (S or AL)-78-14	Steel	25'	46	25-7/8	26-3/8	29-3/8	18-1/4	8-1/8	37-7/8	29'-8"	16'-9-7/8"	5	4
	83'	10'	GLCS-FS-2000-28 (S or AL)-83-10	Steel	20'	46	25-7/8	23	26	18-1/4	8-1/8	37-7/8	29'-8"	12'-5-1/2"	5	5
		10'	AL-FS-2000-28-83-10	Alum	20'	46	21	27-1/2	-	17	8	37-7/8	29'-8"	12'-10"	5	5
		12'	GLCS-FS-2000-28 (S or AL)-83-12	Steel	20'	46	25-7/8	23	26	18-1/4	8-1/8	37-7/8	29'-8"	14'-5-1/2"	5	5
		12'	AL-FS-2000-28-83-12	Alum	20'	46	21	27-1/2	-	17	8	37-7/8	29'-8"	14'-10"	5	5
		14'	GLCS-FS-2000-28 (S or AL)-83-14	Steel	20'	46	25-7/8	23	26	18-1/4	8-1/8	37-7/8	29'-8"	16'-6-1/2"	5	5
		14'	AL-FS-2000-28-83-14	Alum	20'	46	21	27-1/2	-	17	8	37-7/8	29'-8"	16'-11"	5	5
94'	10'	GLCSLX-FS-2000-28 (S or AL)-94-10	Steel	30'	54	25-7/8	29	32	18-1/4	8-1/8	37-7/8	29'-8"	12'-11-1/2"	5	4	
	12'	GLCSLX-FS-2000-28 (S or AL)-94-12	Steel	30'	54	25-7/8	29	32	18-1/4	8-1/8	37-7/8	29'-8"	14'-11-1/2"	5	4	
	14'	GLCSLX-FS-2000-28 (S or AL)-94-14	Steel	30'	54	25-7/8	29	32	18-1/4	8-1/8	37-7/8	29'-8"	17'-0-1/2"	5	4	
	10'	GLCS-FS-2000-28 (S or AL)-103-10	Steel	20'	54	25-7/8	23	26	18-1/4	8-1/8	37-7/8	29'-8"	12'-5-1/2"	5	6	
	10'	AL-FS-2000-28-103-10	Alum	20'	54	21	27-1/2	-	17	8	37-7/8	29'-8"	12'-10"	5	6	
	12'	GLCSL-FS-2000-28 (S or AL)-103-12	Steel	25'	54	25-7/8	26-3/8	29-3/8	18-1/4	8-1/8	37-7/8	29'-8"	12'-8-7/8"	5	5	
103'	12'	GLCSL-FS-2000-28 (S or AL)-103-12	Steel	20'	54	25-7/8	23	26	18-1/4	8-1/8	37-7/8	29'-8"	14'-5-1/2"	5	6	
	12'	AL-FS-2000-28-103-12	Alum	20'	54	21	27-1/2	-	17	8	37-7/8	29'-8"	14'-10"	5	6	
	14'	GLCSL-FS-2000-28 (S or AL)-103-14	Steel	25'	54	25-7/8	26-3/8	29-3/8	18-1/4	8-1/8	37-7/8	29'-8"	14'-8-7/8"	5	5	
	14'	GLCSL-FS-2000-28 (S or AL)-103-14	Steel	20'	54	25-7/8	23	26	18-1/4	8-1/8	37-7/8	29'-8"	16'-6-1/2"	5	6	
	14'	AL-FS-2000-28-103-14	Alum	20'	54	21	27-1/2	-	17	8	37-7/8	29'-8"	16'-11"	5	6	
	14'	GLCSL-FS-2000-28 (S or AL)-103-14	Steel	25'	54	25-7/8	26-3/8	29-3/8	18-1/4	8-1/8	37-7/8	29'-8"	16'-9-7/8"	5	5	
124'	10'	GLCSLX-FS-2000-28 (S or AL)-124-10	Steel	30'	54	25-7/8	29	32	18-1/4	8-1/8	37-7/8	29'-8"	12'-11-1/2"	5	5	
	12'	GLCSLX-FS-2000-28 (S or AL)-124-12	Steel	30'	54	25-7/8	29	32	18-1/4	8-1/8	37-7/8	29'-8"	14'-11-1/2"	5	5	
	14'	GLCSLX-FS-2000-28 (S or AL)-124-14	Steel	30'	54	25-7/8	29	32	18-1/4	8-1/8	37-7/8	29'-8"	17'-0-1/2"	5	5	
34'	28'	10'	GLCSL-FS-2000-34 (S or AL)-28-10	Steel	25'	13	25-7/8	26-3/8	29-3/8	20-7/8	8-1/8	40-1/2	35'-8"	12'-9-7/8"	5	2
		12'	GLCSL-FS-2000-34 (S or AL)-28-12	Steel	25'	13	25-7/8	26-3/8	29-3/8	20-7/8	8-1/8	40-1/2	35'-8"	14'-9-7/8"	5	2
		14'	GLCSL-FS-2000-34 (S or AL)-28-14	Steel	25'	13	25-7/8	26-3/8	29-3/8	20-7/8	8-1/8	40-1/2	35'-8"	16'-11-7/8"	5	2
	33'	10'	GLCS-FS-2000-34 (S or AL)-33-10	Steel	20'	9	25-7/8	25	26	20-7/8	8-1/8	40-1/2	35'-8"	12'-8-1/2"	5	3
		10'	AL-FS-2000-34-33-10	Alum	20'	19	21	27-1/2	-	17-7/8	8	44-5/8	35'-8"	12'-11"	5	3
		12'	GLCS-FS-2000-34 (S or AL)-33-12	Steel	20'	9	25-7/8	25	26	20-7/8	8-1/8	40-1/2	35'-8"	14'-8-1/2"	5	3
		12'	AL-FS-2000-34-33-12	Alum	20'	19	21	27-1/2	-	17-7/8	8	44-5/8	35'-8"	14'-11"	5	3
		14'	GLCS-FS-2000-34 (S or AL)-33-14	Steel	20'	9	25-7/8	25	26	20-7/8	8-1/8	40-1/2	35'-8"	16'-8-1/2"	5	3
		14'	AL-FS-2000-34-33-14	Alum	20'	19	21	27-1/2	-	17-7/8	8	44-5/8	35'-8"	16'-11"	5	3
	34'	10'	GLCSLX-FS-2000-34 (S or AL)-34-10	Steel	30'	9	25-7/8	29	32	20-7/8	8-1/8	40-1/2	35'-8"	13'-2-1/2"	5	2
		12'	GLCSLX-FS-2000-34 (S or AL)-34-12	Steel	30'	9	25-7/8	29	32	20-7/8	8-1/8	40-1/2	35'-8"	15'-2-1/2"	5	2
		14'	GLCSLX-FS-2000-34 (S or AL)-34-14	Steel	30'	9	25-7/8	29	32	20-7/8	8-1/8	40-1/2	35'-8"	17'-2-1/2"	5	2
10'		GLCS-FS-2000-34 (S or AL)-43-10	Steel	20'	13	25-7/8	25	26	20-7/8	8-1/8	40-1/2	35'-8"	12'-8-1/2"	5	3	
10'		AL-FS-2000-34-43-10	Alum	20'	26	21	27-1/2	-	17-7/8	8	44-5/8	35'-8"	12'-11"	5	3	
12'		GLCS-FS-2000-34 (S or AL)-43-12	Steel	20'	13	25-7/8	25	26	20-7/8	8-1/8	40-1/2	35'-8"	14'-8-1/2"	5	3	
43'	12'	AL-FS-2000-34-43-12	Alum	20'	26	21	27-1/2	-	17-7/8	8	44-5/8	35'-8"	14'-11"	5	3	
	14'	GLCS-FS-2000-34 (S or AL)-43-14	Steel	20'	13	25-7/8	25	26	20-7/8	8-1/8	40-1/2	35'-8"	16'-8-1/2"	5	3	
	14'	AL-FS-2000-34-43-14	Alum	20'	26	21	27-1/2	-	17-7/8	8	44-5/8	35'-8"	16'-11"	5	3	
	10'	GLCS-FS-2000-34 (S or AL)-53-10	Steel	20'	13	25-7/8	25	26	20-7/8	8-1/8	40-1/2	35'-8"	12'-8-1/2"	5	4	
	10'	AL-FS-2000-34-53-10	Alum	20'	30	21	27-1/2	-	17-7/8	8	44-5/8	35'-8"	12'-11"	5	4	
	12'	GLCSL-FS-2000-34 (S or AL)-53-12	Steel	25'	13	25-7/8	26-3/8	29-3/8	20-7/8	8-1/8	40-1/2	35'-8"	12'-9-7/8"	5	3	
53'	12'	GLCSL-FS-2000-34 (S or AL)-53-12	Steel	20'	13	25-7/8	25	26	20-7/8	8-1/8	40-1/2	35'-8"	14'-8-1/2"	5	4	
	12'	AL-FS-2000-34-53-12	Alum	20'	30	21	27-1/2	-	17-7/8	8	44-5/8	35'-8"	14'-11"	5	4	
	14'	GLCSL-FS-2000-34 (S or AL)-53-14	Steel	25'	13	25-7/8	26-3/8	29-3/8	20-7/8	8-1/8	40-1/2	35'-8"	14'-9-7/8"	5	3	
	14'	GLCSL-FS-2000-34 (S or AL)-53-14	Steel	20'	13	25-7/8	25	26	20-7/8	8-1/8	40-1/2	35'-8"	16'-8-1/2"	5	4	
	14'	AL-FS-2000-34-53-14	Alum	20'	30	21	27-1/2	-	17-7/8	8	44-5/8	35'-8"	16'-11"	5	4	
	14'	GLCSL-FS-2000-34 (S or AL)-53-14	Steel	25'	13	25-7/8	26-3/8	29-3/8	20-7/8	8-1/8	40-1/2	35'-8"	16'-11-7/8"	5	3	
34'	63'	10'	GLCS-FS-2000-34 (S or AL)-63-10	Steel	20'	19	25-7/8	25	26	20-7/8	8-1/8	40-1/2	35'-8"	12'-8-1/2"	5	4
		10'	AL-FS-2000-34-63-10	Alum	20'	36	21	27-1/2	-	17-7/8	8	44-5/8	35'-8"	12'-11"	5	4
		12'	GLCS-FS-2000-34 (S or AL)-63-12	Steel	20'	19	25-7/8	25	26	20-7/8	8-1/8	40-1/2	35'-8"	14'-8-1/2"	5	4
	64'	12'	AL-FS-2000-34-63-12	Alum	20'	36	21	27-1/2	-	17-7/8	8	44-5/8	35'-8"	14'-11"	5	4
		14'	GLCS-FS-2000-34 (S or AL)-63-14	Steel	20'	19	25-7/8	25	26	20-7/8	8-1/8	40-1/2	35'-8"	16'-8-1/2"	5	4
		14'	AL-FS-2000-34-63-14	Alum	20'	36	21	27-1/2	-	17-7/8	8	44-5/8	35'-8"	16'-11"	5	4
	64'	10'	GLCSLX-FS-2000-34 (S or AL)-64-10	Steel	30'	36	25-7/8	29	32	20-7/8	8-1/8	44-5/8	35'-8"	13'-2-1/2"	5	3
		12'	GLCSLX-FS-2000-34 (S or AL)-64-12	Steel	30'	36	25-7/8	29	32	20-7/8	8-1/8	44-5/8	35'-8"	15'-2-1/2"	5	3
		14'	GLCSLX-FS-2000-34 (S or AL)-64-14	Steel	30'	36	25-7/8	29	32	20-7/8	8-1/8	44-5/8	35'-8"	17'-2-1/2"	5	3
	78'	10'	GLCSL-FS-2000-34 (S or AL)-78-10	Steel	25'	46	25-7/8	26-3/8	29-3/8	20-7/8	8-1/8	44-5/8	35'-8"	12'-9-7/8"	5	4
		12'	GLCSL-FS-2000-34 (S or AL)-78-12	Steel	25'	46	25-7/8	26-3/8	29-3/8	20-7/8	8-1/8	44-5/8	35'-8"	14'-9-7/8"	5	4
		14'	GLCSL-FS-2000-34 (S or AL)-78-14	Steel	25'	46	25-7/8	26-3/8	29-3/8	20-7/8	8-1/8	44-5/8	35'-8"	16'-11-7/8"	5	4
83'	10'	GLCS-FS-2000-34 (S or AL)-83-10	Steel	20'	46	25-7/8	25	26	20-7/8	8-1/8	44-5/8	35'-8"	12'-8-1/2"	5	5	
	10'	AL-FS-2000-34-83-10	Alum	20'	46	21	27-1/2	-	17-7/8	8	44-5/8	35'-8"	12'-11"	5	5	
	12'	GLCS-FS-2000-34 (S or AL)-83-12	Steel	20'	46	25-7/8	25	26	20-7/8	8-1/8	44-5/8	35'-8"	14'-8-1/2"	5	5	
	12'	AL-FS-2000-34-83-12	Alum	20'	46	21	27-1/2	-	17-7/8	8	44-5/8	35'-8"	14'-11"	5	5	
	14'	GLCS-FS-2000-34 (S or AL)-83-14	Steel	20'	46	25-7/8	25	26	20-7/8	8-1/8	44-5/8	35'-8"	16'-8-1/2"	5	5	
	14'	AL-FS-200														

FREE STANDING WORK STATION BRIDGE CRANES

BRIDGE LENGTH (L)	RUNWAY LENGTH	TS	MODEL NUMBER	TRACK MAT.	RUNWAY			BRIDGE				SUPPORT STRUCTURE				
					MAX. L1	L7 in	L8 in	H3 in	H3A in	H4 in	L3 in	L6 in	OAW	OAH	D in	J-BS
34'	28'	10'	GLCSL-FS-4000-34 (S or AL)-28-10	Steel	25'	13	25-7/8	31-3/8	34-1/2	24-3/8	15-1/8	47-1/2	36'-0"	13'-4-7/8"	7	2
		12'	GLCSL-FS-4000-34 (S or AL)-28-12	Steel	25'	13	25-7/8	31-3/8	34-1/2	24-3/8	15-1/8	47-1/2	36'-0"	15'-4-7/8"	7	2
		14'	GLCSL-FS-4000-34 (S or AL)-28-14	Steel	25'	13	25-7/8	31-3/8	34-1/2	24-3/8	15-1/8	47-1/2	36'-0"	17'-4-7/8"	7	2
	33'	10'	GLCS-FS-4000-34 (S or AL)-33-10	Steel	20'	9	25-7/8	29-3/8	32-1/2	24-3/8	15-1/8	47-1/2	36'-0"	13'-2-7/8"	7	3
		12'	GLCS-FS-4000-34 (S or AL)-33-12	Steel	20'	9	25-7/8	29-3/8	32-1/2	24-3/8	15-1/8	47-1/2	36'-0"	15'-2-7/8"	7	3
		14'	GLCS-FS-4000-34 (S or AL)-33-14	Steel	20'	9	25-7/8	29-3/8	32-1/2	24-3/8	15-1/8	47-1/2	36'-0"	17'-2-7/8"	7	3
	34'	10'	GLCSLX-FS-4000-34 (S or AL)-34-10	Steel	30'	9	25-7/8	32-3/8	35-1/2	24-3/8	15-1/8	47-1/2	36'-0"	13'-5-7/8"	7	2
		12'	GLCSLX-FS-4000-34 (S or AL)-34-12	Steel	30'	9	25-7/8	32-3/8	35-1/2	24-3/8	15-1/8	47-1/2	36'-0"	15'-5-7/8"	7	2
		14'	GLCSLX-FS-4000-34 (S or AL)-34-14	Steel	30'	9	25-7/8	32-3/8	35-1/2	24-3/8	15-1/8	47-1/2	36'-0"	17'-5-7/8"	7	2
	43'	10'	GLCS-FS-4000-34 (S or AL)-43-10	Steel	20'	13	25-7/8	29-3/8	32-1/2	24-3/8	15-1/8	47-1/2	36'-0"	13'-2-7/8"	7	3
		12'	GLCS-FS-4000-34 (S or AL)-43-12	Steel	20'	13	25-7/8	29-3/8	32-1/2	24-3/8	15-1/8	47-1/2	36'-0"	15'-2-7/8"	7	3
		14'	GLCS-FS-4000-34 (S or AL)-43-14	Steel	20'	13	25-7/8	29-3/8	32-1/2	24-3/8	15-1/8	47-1/2	36'-0"	17'-2-7/8"	7	3
	53'	10'	GLCS-FS-4000-34 (S or AL)-53-10	Steel	20'	13	25-7/8	29-3/8	32-1/2	24-3/8	15-1/8	47-1/2	36'-0"	13'-2-7/8"	7	4
		12'	GLCSL-FS-4000-34 (S or AL)-53-10	Steel	25'	13	25-7/8	31-3/8	34-1/2	24-3/8	15-1/8	47-1/2	36'-0"	13'-4-7/8"	7	3
		12'	GLCS-FS-4000-34 (S or AL)-53-12	Steel	20'	13	25-7/8	29-3/8	32-1/2	24-3/8	15-1/8	47-1/2	36'-0"	15'-2-7/8"	7	4
		12'	GLCSL-FS-4000-34 (S or AL)-53-12	Steel	25'	13	25-7/8	31-3/8	34-1/2	24-3/8	15-1/8	47-1/2	36'-0"	15'-4-7/8"	7	3
	63'	10'	GLCSL-FS-4000-34 (S or AL)-63-10	Steel	20'	13	25-7/8	29-3/8	32-1/2	24-3/8	15-1/8	47-1/2	36'-0"	13'-2-7/8"	7	4
		12'	GLCS-FS-4000-34 (S or AL)-63-12	Steel	20'	19	25-7/8	29-3/8	32-1/2	24-3/8	15-1/8	47-1/2	36'-0"	15'-2-7/8"	7	4
		14'	GLCS-FS-4000-34 (S or AL)-63-14	Steel	20'	19	25-7/8	29-3/8	32-1/2	24-3/8	15-1/8	47-1/2	36'-0"	17'-2-7/8"	7	4
	64'	10'	GLCSLX-FS-4000-34 (S or AL)-64-10	Steel	30'	36	25-7/8	32-3/8	35-1/2	24-3/8	15-1/8	51-5/8	36'-0"	13'-5-7/8"	7	3
		12'	GLCSLX-FS-4000-34 (S or AL)-64-12	Steel	30'	36	25-7/8	32-3/8	35-1/2	24-3/8	15-1/8	51-5/8	36'-0"	15'-5-7/8"	7	3
		14'	GLCSLX-FS-4000-34 (S or AL)-64-14	Steel	30'	36	25-7/8	32-3/8	35-1/2	24-3/8	15-1/8	51-5/8	36'-0"	17'-5-7/8"	7	3
	78'	10'	GLCSL-FS-4000-34 (S or AL)-78-10	Steel	25'	46	25-7/8	31-3/8	34-1/2	24-3/8	15-1/8	51-5/8	36'-0"	13'-4-7/8"	7	4
		12'	GLCSL-FS-4000-34 (S or AL)-78-12	Steel	25'	46	25-7/8	31-3/8	34-1/2	24-3/8	15-1/8	51-5/8	36'-0"	15'-4-7/8"	7	4
		14'	GLCSL-FS-4000-34 (S or AL)-78-14	Steel	25'	46	25-7/8	31-3/8	34-1/2	24-3/8	15-1/8	51-5/8	36'-0"	17'-4-7/8"	7	4
	83'	10'	GLCS-FS-4000-34 (S or AL)-83-10	Steel	20'	46	25-7/8	29-3/8	32-1/2	24-3/8	15-1/8	51-5/8	36'-0"	13'-2-7/8"	7	5
		12'	GLCS-FS-4000-34 (S or AL)-83-12	Steel	20'	46	25-7/8	29-3/8	32-1/2	24-3/8	15-1/8	51-5/8	36'-0"	15'-2-7/8"	7	5
		14'	GLCS-FS-4000-34 (S or AL)-83-14	Steel	20'	46	25-7/8	29-3/8	32-1/2	24-3/8	15-1/8	51-5/8	36'-0"	17'-2-7/8"	7	5
	94'	10'	GLCSLX-FS-4000-34 (S or AL)-94-10	Steel	30'	54	25-7/8	32-3/8	35-1/2	24-3/8	15-1/8	51-5/8	36'-0"	13'-5-7/8"	7	4
		12'	GLCSLX-FS-4000-34 (S or AL)-94-12	Steel	30'	54	25-7/8	32-3/8	35-1/2	24-3/8	15-1/8	51-5/8	36'-0"	15'-5-7/8"	7	4
		14'	GLCSLX-FS-4000-34 (S or AL)-94-14	Steel	30'	54	25-7/8	32-3/8	35-1/2	24-3/8	15-1/8	51-5/8	36'-0"	17'-5-7/8"	7	4
	103'	10'	GLCS-FS-4000-34 (S or AL)-103-10	Steel	20'	54	25-7/8	29-3/8	32-1/2	24-3/8	15-1/8	51-5/8	36'-0"	13'-2-7/8"	7	6
		10'	GLCSL-FS-4000-34 (S or AL)-103-10	Steel	25'	54	25-7/8	31-3/8	34-1/2	24-3/8	15-1/8	51-5/8	36'-0"	13'-4-7/8"	7	5
		12'	GLCS-FS-4000-34 (S or AL)-103-12	Steel	20'	54	25-7/8	29-3/8	32-1/2	24-3/8	15-1/8	51-5/8	36'-0"	15'-2-7/8"	7	6
		12'	GLCSL-FS-4000-34 (S or AL)-103-12	Steel	25'	54	25-7/8	31-3/8	34-1/2	24-3/8	15-1/8	51-5/8	36'-0"	15'-4-7/8"	7	5
	124'	10'	GLCS-FS-4000-34 (S or AL)-103-14	Steel	20'	54	25-7/8	29-3/8	32-1/2	24-3/8	15-1/8	51-5/8	36'-0"	17'-2-7/8"	7	6
		10'	GLCSL-FS-4000-34 (S or AL)-103-14	Steel	25'	54	25-7/8	31-3/8	34-1/2	24-3/8	15-1/8	51-5/8	36'-0"	17'-4-7/8"	7	5
		10'	GLCSLX-FS-4000-34 (S or AL)-124-10	Steel	30'	54	25-7/8	32-3/8	35-1/2	24-3/8	15-1/8	51-5/8	36'-0"	13'-5-7/8"	7	5
	124'	12'	GLCSLX-FS-4000-34 (S or AL)-124-12	Steel	30'	54	25-7/8	32-3/8	35-1/2	24-3/8	15-1/8	51-5/8	36'-0"	15'-5-7/8"	7	5
		14'	GLCSLX-FS-4000-34 (S or AL)-124-14	Steel	30'	54	25-7/8	32-3/8	35-1/2	24-3/8	15-1/8	51-5/8	36'-0"	17'-5-7/8"	7	5

*This column provides the total number of support assemblies based on the "L1" dimensions shown. Dimensions are for reference only and are subject to change without notice.

Options When Using Multiple Bridges

MIXED CAPACITY SYSTEMS

Bridges are sized for an individual rated load. Runways are sized for the *combined* weight of all loads, so they use a heavier track series than the bridges.

Advantages:

- No “dead” coverage areas (areas with no bridge coverage). Each bridge can travel the length of the system.
- Limited “dead” coverage areas between bridges, so bridges can be used side-by-side .
- Bridges weigh less, making them easier to move.

Disadvantage:

- Use larger sized runways, so they may cost more than intermediate stops or bridge buffer systems.

BRIDGE BUFFER SYSTEMS

Bridges are sized for an individual rated load. Runways are sized for the heaviest *individual* load, so the runways use the same track series as the largest bridge. Bridges are physically separated by wheeled, movable bridge buffers.

Advantage:

- Usually cost less than mixed capacity systems because they typically use smaller sized runways.

Disadvantage:

- Buffers take up space, creating a moving “dead” space between bridges.

Note: With two bridges, the dead space equals half the distance of the support centers (L1 from the dimensional charts). When a third bridge is added, the dead space occupied by the additional bridge buffers equals the distance of the support centers. Special support steel may be required.

SYSTEMS WITH INTERMEDIATE STOPS

Bridges are sized for an individual rated load. Runways are sized for the heaviest *individual* load, so the runways are same size as largest bridge. Bridges are physically separated by *internal stops or bumpers*. Extra hangers may be required to eliminate overload.

Advantages:

- Use smaller runways, therefore typically cost less than mixed capacity systems.
- Fewer potential “dead” spots in the system.

Disadvantages:

- Each bridge on the system can travel only a portion of the length of the system.
- May cost more to install since they require extra supports to eliminate an overload situation.

MIXED CAPACITY SYSTEM

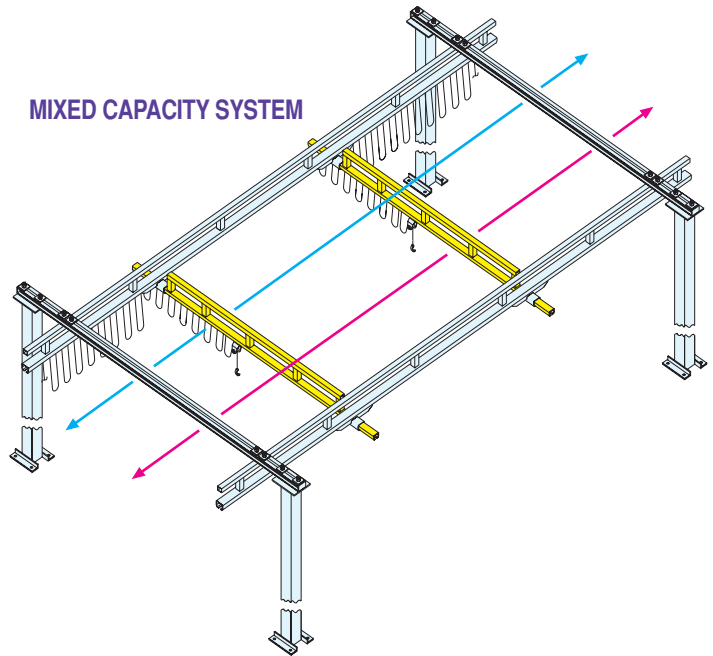

BRIDGE BUFFER SYSTEM

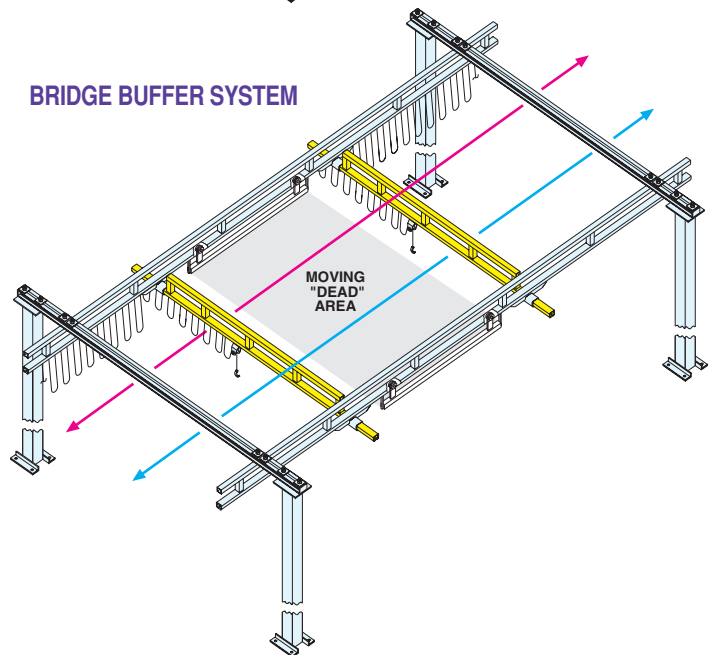

INTERMEDIATE STOPS SYSTEM

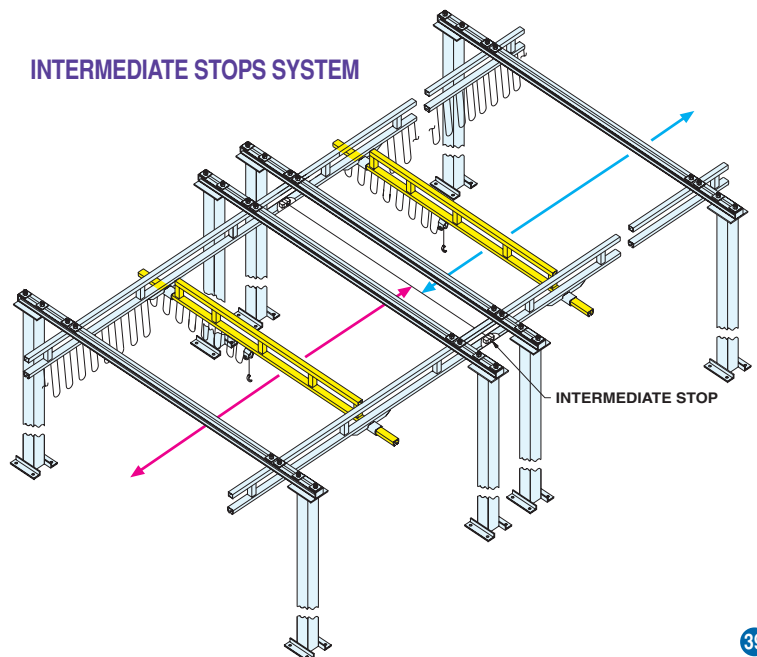

FOR MORE INFORMATION

Your authorized Gorbel® dealer can give you more information on what makes Gorbel's Ergonomic Work Station Cranes and other material handling products "A Class Above."

BRIDGE CRANES



FREE STANDING

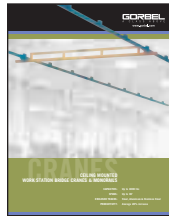

CEILING MOUNTED



ERGONOMIC STUDY

ERGONOMIC LIFTING



G-FORCE®



EASY ARM™



ERGONOMIC STUDY

JIB CRANES



JIB CRANES

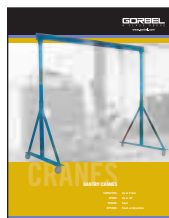

GANTRY CRANES



WORK STATION JIBS



ARTICULATING JIBS

SPECIALTY PRODUCTS



SEISMIC ZONE IV



TELESCOPING



TRACTOR DRIVES



INTERLOCK/TRANSFER

GORBEL®
A CLASS ABOVE

www.gorbels.com

GORBEL
600 Fishers Run
PO Box 593
Fishers, NY 14453 USA

T 800.821.0086
T 585.924.6262
F 585.924.6273
E info@gorbel.com

©2008 Gorbel Inc.
All Rights Reserved

CRANES

